

FOAM SYSTEMS DESIGN & APPLICATIONS MANUAL



Table of Contents

Section 1: About Perimeter Solutions

History
Culture
Vision And Mission
Revolutionizing Firefighting Foam Technologies

Section 2: RE-HEALING™ Foam

Environmental Stewardship
RE-HEALING™ Foam Concentrate FAQ
Technical Reference Guide RE-HEALING™ Foam Concentrate
Aquatic Impact of Fire Fighting Foams
RE-HEALING™ Foam Fire Performance
Fluorine-Free Foams - Not All Concentrates are Equal
Fluorine-Free Foams - Fact vs Fiction
Foam System Checklist

Section 3: Introduction

Fire Tetrahedron
Classes Of Fire (America)
Classes Of Fire (European)
How Foam Is Made
Foam Characteristics
Foam Testing
Foam Handling
Types Of Foam
Evolution Of Class B Firefighting Foams

Section 4: Foam Concentrate Data Sheets

4.1 RE-HEALING™ Foam Concentrates
4.2 ARCTIC™ Foam Concentrates
4.3 FIRE-BRAKE™ Foam Concentrate
4.4 Specialized Foam Concentrates

Section 5: Foam Hardware Data Sheets

5.1 Tank Systems
5.2 Proportioning Systems
5.3 Discharge Devices
5.4 Mobile Products

TABLE OF CONTENTS

Section 6: Applications

- 6.1 Aircraft Hangar Protection
- 6.2 Diked Area/Spill Protection
- 6.3 Foam-Water Sprinkler Systems (Warehouse/Storage Areas)
- 6.4 Heliport Protection
- 6.5 High Expansion Foam Systems
- 6.6 Loading Rack Protection
- 6.7 Storage Tank Protection

Section 7: Appendix

- Foam Glossary
- CAD Drawing Symbols
- General Reference – Standards And Publications
- Around-the-pump Proportioning Systems
- Comparison Of Proportioning System Types
- Unit of Measurement Conversions – U.S. to Metric
- Basic Hydraulic Calculations
- Pipe Tables
- Equivalent Pipe Length Tables
- Friction Loss Tables
- Hose Friction Loss Table
- Straight Bore Discharge Data
- Understand Fire Detection Devices

Section 8: Material Safety Data Sheets

- RE-HEALING™ Foam Concentrates
- ARCTIC™ Foam Concentrates
- FIRE-BRAKE™ Foam Concentrate
- Specialized Foam Concentrates

Section 9: FM Global Property Loss Prevention Data Sheets

- Data Sheet 4-12: Foam-Water Sprinkler Systems

Section 10: Technical documents

PERIMETER-SOLUTIONS.COM

UNITED STATES

1520 Brookfield Avenue
Green Bay, WI 54313
Tel: +1 (920) 593-9445
salesfoamusa@perimeter-solutions.com

EMEA

Polígono Industrial de Baiña
Parcela 23
33682 Baiña-Mieres (Asturias)
Spain
Tel: +34 985 24 29 45
salesfoamea@perimeter-solutions.com

ASIA-PACIFIC

3 Charles Street
St Marys NSW 2760
Australia
Tel: +61 2 9673 5300
salesfoamapac@perimeter-solutions.com





SECTION 1

ABOUT PERIMETER SOLUTIONS

About Perimeter Solutions

Perimeter Solutions is a premier global solutions provider, producing high-quality lubricant additives and firefighting chemicals. We develop products that impact critically important issues of life – issues where there often is no room for error and the job doesn't offer second chances.

At Perimeter, we characterize the solutions we develop as 'Solutions that Save' – because it helps underscore what we are trying to accomplish for our customers, and the world at large, across all of our business segments

Culture

At Perimeter Solutions, we take Corporate Social Responsibility to be good stewards of the environment seriously and are committed to reducing our environmental footprint and operating safely and sustainably. People are our goal – not a means to an end.

Product Management: Perimeter Solutions makes significant investments in product improvements and new technologies that improve the health, safety and environmental aspects of our products.

Process Management: Perimeter Solutions continues to discuss and implement ideas to reduce waste throughout our manufacturing process by focusing on process improvements, waste reduction and re-use/recycling.

Vision And Mission

To be the customer's first choice through exceeding expectations each and every time.

Vision Statement

Be the indisputable global leader in the fire protection and oil additive industries.

Mission Statement

Perimeter Solutions employees help save lives and protect property and the environment by delivering quality products and exceptional services.

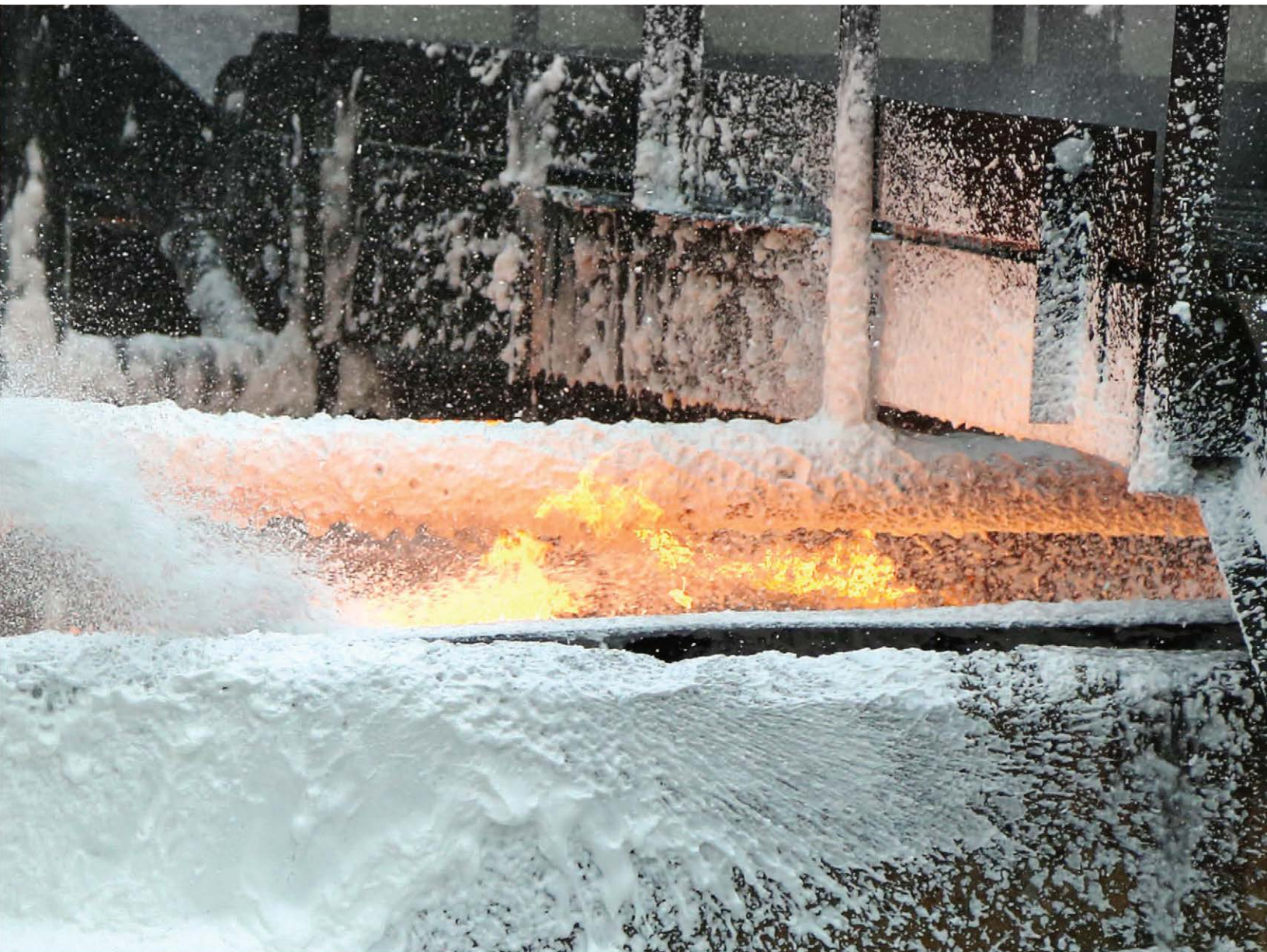

REVOLUTIONIZING
FIREFIGHTING FOAM TECHNOLOGIES



NO MORE BLENDING IN _____

For more than 40 years, SOLBERG blended foam for some of the biggest names in the fire suppression industry. Not anymore. We're not just blending foams. We're reinventing them. Our R&D scientists continually pioneer firefighting foam technologies that aren't just setting industry standards - they're raising the bar. So the only label you need to look for says SOLBERG - a name recognized and respected around the world.

*We don't just
talk about innovation*

WE SHOW IT

Innovation isn't just about making something new or different. It also has to be relevant. We are watching industries around the world, monitoring what's happening now, and determining what will be needed in the future. We rely on our global research to make breakthrough products that are exceptionally effective and always relevant.

Solberg RE-HEALING™ and FIRE-BRAKE™ foam concentrates are outstanding examples of innovative answers to the world's need for firefighting foams. They fulfill stringent fire performance criteria, pass environmental safety standards, and do not contain substances hazardous to the natural environment.

INDUSTRIES: Aerospace / Aviation / Chemical
Defense / Energy / Fire Services / Marine / Mining
Oil & Gas / Petrochemical / Pharmaceuticals
Pipelines / Solvents & Coatings / Utilities

APPLICATIONS: Aerospace / Aircraft Hangars
Crash Rescue Vehicles / Dike Areas / Docks
Heliports & Helidecks / Jetties / Loading Racks
Manufacturing Processes / Pumping Stations
Power Plants / Storage Tanks / Warehouses



The first true high-performance, sustainable fluorosurfactant and fluoropolymer-free foam for Class B fires, with no environmental concerns.



The first U.S. EPA Stewardship Program – 2015 Compliant C₀ Foam Concentrates. ARCTIC AFFF and AR-AFFF concentrates are for Class B fires.



Designed for wild-land, structural, and other Class A fuel fires, This USFS Qualified Products List foam concentrate is biodegradable and non-toxic.

WE'VE WALKED MILES IN YOUR BOOTS

The best research comes from people who aren't afraid to get their hands dirty and their boots wet. SOLBERG foam concentrates and systems hardware are developed by a team that has more than 200 years of combined in-the-field fire protection experience. They know what's at stake, and design customized systems that will best protect people and the world around us.

We roll up our sleeves

No Perimeter Solutions product goes out the door until it is rigorously assessed, proved, and improved at our state-of-the-art research and test facilities in Europe and North America. Our facilities also provide a controlled environment in which our experts can hold demonstrations and training workshops with our customers.

At Perimeter Solutions, it's not business as usual. Not only do we want to provide you with superior foam concentrates and systems hardware, we want you to be able to use them effectively – and safely. We'll do whatever it takes to make it happen. Whether it's training, hazard analysis or technical support, we have the experience, knowledge and responsive people to ensure you have the right product for your specific industry and applications.

Perimeter Solutions also offers the best in Custom-Designed Hardware for accurate proportioning with high-performance and reliability.

- System Tanks
- Proportioning Devices
- Discharge Devices
- Mobile Products



PRODUCTS RELEVANT TO TODAY'S EVER-CHANGING DEMANDS

SOLBERG has developed some of the most advanced foam concentrates and systems hardware on the market. With industry-leading experts, worldwide experience and global reach, we continually pioneer firefighting foam concentrate technologies to meet the latest demands in the industry. RE-HEALING™ and FIRE-BRAKE™ foam concentrates are innovative answers to the world's need for firefighting foams that fulfill stringent fire performance criteria, pass environmental safety standards, and do not contain persistent pollutants.





GLOBAL REACH

Perimeter Solutions is based in Clayton, Missouri with operations in Canada, France, Spain, Australia, and Germany. Involved in the manufacture of firefighting foams since the mid-70s, Perimeter Solutions has the expertise, capabilities, and resources to serve the fire protection and firefighting industry. Perimeter's people and processes are committed to quality, service, and safety along with environmental responsibility.



*A Culture Driven By People
With Real-World Experience*

OUR COMMITMENT

- Manufacture high quality and performance products
- Easy to do business with
- Partnering and relationships
- Deliver orders complete and on time
- Responsiveness
- Continuous innovation
- Encompass quality, health and safety
- Environmental responsibility

Perimeter Solutions is a premier global solutions provider, producing high-quality firefighting products. The company develops products that impact critically important issues of life – issues where there often is no room for error and the job doesn't offer second chances. At Perimeter, we characterize the solutions we develop as 'Solutions That Save' – because it helps underscore what we are trying to accomplish for our customers and the world at large, across all of our business segments. perimeter-solutions.com



The background features a gradient from yellow-orange on the left to red on the right. Large, semi-transparent geometric shapes, including a large triangle and a circle, are layered over the gradient.

SECTION 2
RE-HEALING™ FOAM

Environmental Stewardship

Perimeter Solutions Company Position on Fluorine Containing Firefighting Foams

It is the position of Perimeter Solutions that RE-HEALING™ Foam (RF) is the World's most effective firefighting foam concentrate for flame knockdown, fire control, extinguishment, and burn-back resistance. Control, extinguishing time, and burn-back resistance are paramount to the safety of firefighters everywhere, and RE-HEALING foam is superior to all other foam concentrates, whether protein or synthetic, fluorinated or not.

The Voluntary Stewardship Program of the US EPA stated that by the end of 2010, the industry would achieve an intermediate goal of a 95% reduction in the production and use of long-chain perfluorinated chemicals (LCPFCs). By the end of 2015, the goal was to phase out the production and use of long-chain perfluorinated chemicals. Perimeter Solutions achieved full 2015 compliance with its full range of RE-HEALING foam concentrates.

While this Voluntary Stewardship Program addresses the Persistence, Bioaccumulation, and Toxicity (PBT) of long chain perfluorinated chemicals, it does not address the firefighting performance of foam concentrates based on the newer generation of short-chain perfluorinated chemicals. It is the position of Perimeter Solutions that the change for fluorine containing foam concentrates, to short chain perfluorinated chemicals, has had a significant negative impact on firefighting performance and burn-back resistance. As a result, fluorine-containing foam concentrates now require significantly greater levels of fluorinated surfactants than pre-2010 compliant foam concentrates to achieve the same levels of firefighting performance. Furthermore, it is Perimeter Solutions' official position that all fluorine containing firefighting foams that are modified to achieve the 2010 and 2015 EPA Voluntary targets should have their existing approvals reviewed and fully re-tested to prove that the stated level of performance has not been compromised.

Perimeter Solutions is committed to leading the foam fire suppression industry with innovative and high performance products.

TECHNICAL BULLETIN

RE-HEALING™ Foam Concentrate FAQ

Q: What are RE-HEALING™ foam concentrates from SOLBERG®?

A: RE-HEALING foam concentrates from SOLBERG are synthetic firefighting foam concentrates designed for a broad range of applications through conventional fire protection equipment and systems, without the use of fluorosurfactant, fluoropolymer or fluorotelomer chemistry which have been proven to be Persistent in the environment, Bio-accumulative (gets into the food-chain) and Toxic (PBT). RE-HEALING foam concentrates deliver rapid-fire extinguishment of hydrocarbon and polar solvent fuels.

RE-HEALING foam concentrates represent an inherent resilience to burn back while providing sustainable longevity of flammable, toxic or noxious vapor suppression. They are the first high performance alternative foams that have an Aqueous Film Forming Foam (AFFF) like performance.

Q: How do RE-HEALING foam concentrates work?

A: RE-HEALING foam concentrates represent a new innovative alternative product to traditional AFFF, AR-AFFF, FP, and FFFP foam concentrates. The technology has the ability to flow rapidly and freely across the surface of a hydrocarbon flammable liquid without film forming technology. Their structure is high temperature resistant and will stick to hot metal surfaces.

Q: What are the applications?

A: RE-HEALING foam concentrates from SOLBERG are suitable for both fighting flammable liquid fires and preventing fire in the event of chemical spills. They effectively cool and seal the fuel, suppressing vapors and greatly reducing the risk of fire and hazardous vapor clouds.

RE-HEALING foam concentrates can be used with fresh, salt and brackish water and are compatible with dry chemical agents.

RE-HEALING foam concentrates fast flowing foam blanket provide better control and extinguishment than protein-based agents. Because the fast flowing foam blanket extinguishes and secures rapidly, RE-HEALING foam concentrates also provide significantly improved bum back resistance.

When stored in original containers or in manufacturer recommended equipment and within the specified temperature range, shelf life is a minimum 10 of years. Should freezing occur, thawing and agitating will render concentrates useful. Freezing and thawing will not cause loss of product quality.

Q: Will RE-HEALING foam concentrates suppress vapors?

A: RE-HEALING foam concentrates from SOLBERG can be used to prevent re-ignition of a liquid spill and control hazardous vapors.



Q: What size packaging options are available?

A: Container packaging options include: 5 gallon (20 litre) pails, 55 gallon (200 litre) drums, 265 gallon (1000 litre) totes and bulk haulage tankers for larger volumes.

Q: Will RE-HEALING foam concentrates meet our needs?

A: RE-HEALING foam concentrates are the first and only fluorosurfactant and fluoropolymer-free based foam concentrate designed to meet or exceed the ICAO Level B rating.

They are tested to European Standard EN 1568.

RE-HEALING foam concentrates are compatible with available systems and conform to the exacting quality requirements set by Standards Australia.

RE-HEALING foam concentrates have been tested to Underwriters Laboratories, Inc. (UL) Standard 162.

RE-HEALING foam concentrates are manufactured in the United States, Norway and Australia. Prompt delivery can also be obtained via SOLBERG's network of authorized distributors worldwide.

Q: What about RE-HEALING foam concentrates & the environment?

A: RE-HEALING foam concentrates are fluorosurfactant, fluoropolymer-free products for use on Class B

hydrocarbon and polar solvent fuels with no environmental concerns for Persistence, Bioaccumulation or Toxic (PBT) breakdown.

Q: Are RE-HEALING foam concentrates compatible with our current foam?

A: RE-HEALING foam concentrates should not be mixed with other brands of foam concentrates. When applied to a fire as a foam solution, they can be mixed with similar foam types.

Q: What about materials of construction compatibility?

A: RE-HEALING foam concentrates are compatible with multiple materials of construction such as carbon steel, stainless steel, brass and PVC. Galvanized steel should not be used.

Q: I have existing foam systems containing traditional fluorine based foam concentrates and I want to change to RE-HEALING foam concentrates.

A: Consult SOLBERG Technical Services

Q: How effective are RE-HEALING foam concentrates on Class A fires?

A: The use of RE-HEALING foam concentrates is not limited to Class "B" fires. On Class "A" fuels, they will improve extinguishment in deep-seated fires and are also useful on mixed Class A and B fires.

Q: Do RE-HEALING foam concentrates form precipitates?

A: No, all raw materials are water soluble and stable. The formation of sediments is a historical issue associated with the denaturing of proteins used in FP, FFFP, and Protein foam concentrates.

Q: Is there dry powder compatibility with RE-HEALING foam concentrates?

A: Yes, RE-HEALING foam concentrates are compatible with most powder (dry chemical) agents.

Q: How do I contact SOLBERG?

A: SOLBERG is an Amerex Corporation company with a European heritage. We've grown steadily over the past thirty years, focused first on Europe, then expanding into the Asia Pacific Region. Today, SOLBERG has the expertise, capabilities and resources to serve the fire protection and firefighting industry throughout the world.

Contact a SOLBERG factory sales representative for personal service.

AMERICAS: +1 920 593 9445

EMEA: +47 56 34 97 00

ASIA-PACIFIC: +61 2 9673 5300



Technical Reference Guide RE-HEALING™ FOAM CONCENTRATE





Table of Contents

Introduction

RE-HEALING™ RF Class B Foam Concentrates.....	2
RE-HEALING™ RF 3x6 ATC™ Class B Foam Concentrates.....	2
RE-HEALING™ RF Class B Foam Systems.....	3

Performance

General.....	3
Advantages.....	3
Performance Guidelines.....	4

RE-HEALING Foam Concentrates

Physical Properties.....	6
Storage and Stability.....	7
Agent Testing.....	7
Water Considerations.....	7
Compatibility with Other Class “B” Agents.....	7
Environmental Compatibility.....	7

Materials of Construction

Materials and Testing.....	7
Tanks.....	8
Piping and Fittings.....	8
Valves.....	8
Pumps.....	8
Gaskets.....	8
Seals and Paints.....	8
Metals.....	9
Dissimilar Metals.....	9
Fiberglass.....	9
Lubricants, Seals and Packing.....	9
Plastics.....	10
Typical Metal Corrosion.....	11
Compatibility with Elastomers.....	12



I. Introduction

A. RE-HEALING RF Foam Concentrates

RE-HEALING RF foam concentrate is a synthetic, foaming liquids designed for use with fresh, sea or brackish water. When mixed as recommended with water, RE-HEALING foam concentrates are excellent in control and extinguishment of hydrocarbon fuel fires. They are a pseudo plastic due to the resin used in the concentrate which assists the foam stability and long drain time.

RF foam on non polar, water insoluble flammable liquids (hydrocarbons), forms a rapidly flowing foam blanket that floats over the fuel surface. The foam blanket is stable and free flowing, given its RE-HEALING properties. This action is achieved without the use of fluorochemicals (polymers and surfactants) which is unique to RF concentrates, providing an effective vapor seal which rapidly extinguishes and prevents re-ignition.

B. RE-HEALING ATC Foam Concentrates

RE-HEALING ATC and RF foam are synthetic multipurpose foam forming liquids designed for protection of water soluble solvents and water insoluble hydrocarbon flammable liquids. The effectiveness of RE-HEALING ATC foam on a wide range of flammable liquids and ordinary combustibles eliminates the need to stock a variety of fire fighting agents.

On water soluble polar solvents, RE-HEALING foam concentrate forms a cohesive polymeric layer on the fuel surface. The polymeric layer protects the foam from breakdown by polar solvents. If the protective layer should become disrupted, more of the polymeric layer is produced by means of a regenerative action known as RE-HEALING. This unique action enables the foam to extinguish and secure effectively; thus providing superior burn back protection.

**HYDROCARBON FLAMMABLE LIQUID
(WATER INSOLUBLE)**

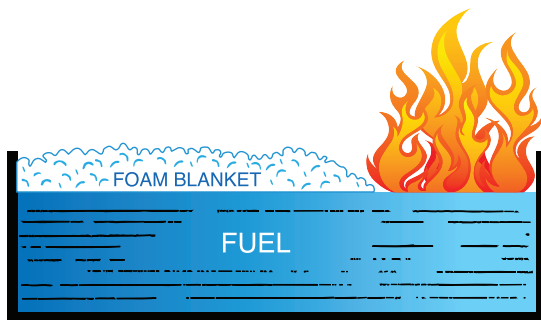

**POLAR SOLVENT FLAMMABLE LIQUID
(WATER SOLUBLE)**

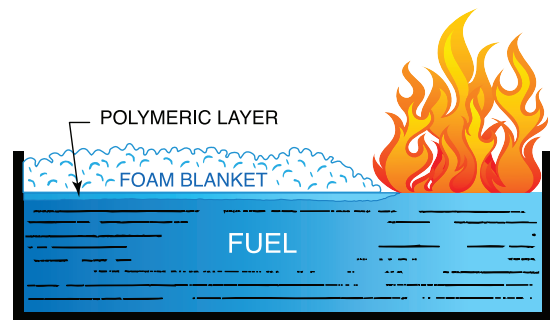



C. RE-HEALING RF Foam Fixed Suppression Systems

System designs are available for optimum effectiveness utilizing RE-HEALING foam concentrates. These system designs are based on listings and approvals by the recognized fire protection laboratories and the recommendations of applicable NFPA codes. Since each fire protection problem can involve unique considerations, please contact your local factory sales representative or Solberg technical services for assistance in design, equipment procurement and system installation.

II. Performance

A. General

This section identifies the advantages of using RE-HEALING foam concentrates and performance data that demonstrate their effectiveness on a broad range of flammable liquid hazards, as well as Class A type fires.

B. Advantages of RE-HEALING Foam Concentrates

- RE-HEALING foam concentrates are more effective at controlling and extinguishing a flammable liquid fire.
- RE-HEALING foam concentrates are useful for securing non burning surfaces of hydrocarbon or polar solvent fuel fires and spills against ignition.
- Storage tank protection systems can be used to suppress fuel tank fires (with resultant cooling of hot metal) and to seal against the tank shell area without great depths of foam.
- RE-HEALING RF foam concentrates can be dispensed effectively through non aspirating and aspirating equipment including fog/straight stream nozzles, fog-foam nozzles.
- RE-HEALING foam concentrates can limit 3 dimensional spill fire spread to the area of the 3 D spill. This allows the use of supplemental agents, such as dry chemicals, for extinguishment.
- RE-HEALING foam concentrates may be applied to fires simultaneously with dry chemical fire fighting agents because the agents are mutually effective and compatible. Compatibility with other aqueous foamed agents is satisfactory when applied in separate foam streams.
- RE-HEALING foam concentrates possess excellent Class A fire suppressing abilities. They effectively extinguish deep seated fires in wood, paper, cotton and other ordinary combustibles. Additionally, they are very effective on the combination Class A and Class B fires resulting from burning rubber, plastic and other polymeric materials.
- RE-HEALING foam concentrates are the most cost effective agents for the protection of flammable liquid hazards since they exhibit excellent fire extinguishment, re-flash securing and long shelf life.



C. Performance of RE-HEALING Foam Concentrates on Solvent Spill Fires (Hand Line Application)

Product (% concentration)	Fire Size	Fuel	Nozzle	Application Density
RE-HEALING Foam @ 6%	3.0 ft ² (0.28 m ²)	AVTUR/FW	Def.Aust.	0.06 gpm/ft ² (2.42 lpm/m ²)
		AVGAS/SW	Def.Aust.	0.06 gpm/ft ² (2.42 lpm/m ²)
		AVTUR/FW	Def.Aust.	0.06 gpm/ft ² (2.42 lpm/m ²)
		AVGAS/SW	Def.Aust.	0.06 gpm/ft ² (2.42 lpm/m ²)
		91 Octane	Def.Aust.	0.06 gpm/ft ² (2.42 lpm/m ²)
		96 Octane	Def.Aust.	0.06 gpm/ft ² (2.42 lpm/m ²)
		Light Tops	Def.Aust.	0.06 gpm/ft ² (2.42 lpm/m ²)
		91 Octane/10% Ethanol	Def.Aust.	0.06 gpm/ft ² (2.42 lpm/m ²)
		91 Octane/15% Ethanol	Def.Aust.	0.06 gpm/ft ² (2.42 lpm/m ²)
		91 Octane/20% Ethanol	Def.Aust.	0.06 gpm/ft ² (2.42 lpm/m ²)
	28 ft ² (2.6 m ²)	Unleaded/FW	US Mil	0.08 gpm/ft ² (2.92 lpm/m ²)
	48.4 ft ² (4.5 m ²)	AVTUR/FW	ICAO	0.07 gpm/ft ² (2.56 lpm/m ²)
		AVTUR/FW	ICAO	0.07 gpm/ft ² (2.56 lpm/m ²)
1076 ft ² (100 m ²)	Light Crude Oil	59 gpm (225 lpm)	0.06 gpm/ft ² (2.25 lpm/m ²)	
1615 ft ² (150 m ²)	AVTUR (1000L)	1261 gpm (4775 lpm)	0.80 gpm/ft ² (31.83 lpm/m ²)	
1615 ft ² (150 m ²)	96 Octane	151 gpm (570 lpm)	0.09 gpm/ft ² (3.8 lpm/m ²)	
	Condensate	151 gpm (570 lpm)	0.09 gpm/ft ² (3.8 lpm/m ²)	

Product (% concentration)	Fire Size	Fuel	Nozzle	Application Density	
RE-HEALING Foam @ 3%	3.0 ft ² (0.28 m ²)	AVTUR/FW	Def.Aust.	0.06 gpm/ft ² (2.42 lpm/m ²)	
		AVGAS/SW	Def.Aust.	0.06 gpm/ft ² (2.42 lpm/m ²)	
		AVTUR/FW	Def.Aust.	0.06 gpm/ft ² (2.42 lpm/m ²)	
		AVGAS/SW	Def.Aust.	0.06 gpm/ft ² (2.42 lpm/m ²)	
		91 Octane	Def.Aust.	0.06 gpm/ft ² (2.42 lpm/m ²)	
		96 Octane	Def.Aust.	0.06 gpm/ft ² (2.42 lpm/m ²)	
		Light Tops	Def.Aust.	0.06 gpm/ft ² (2.42 lpm/m ²)	
		Shell Optimax	Def.Aust.	0.06 gpm/ft ² (2.42 lpm/m ²)	
		28 ft ² (2.6 m ²)	Unleaded/FW	US Mil	0.08 gpm/ft ² (2.92 lpm/m ²)
		48.4 ft ² (4.5 m ²)	AVTUR/FW	ICAO	0.07 gpm/ft ² (2.56 lpm/m ²)
	AVTUR/FW		ICAO	0.07 gpm/ft ² (2.56 lpm/m ²)	
	1076 ft ² (100 m ²)	Light Crude Oil	148 gpm (562 lpm)	0.14 gpm/ft ² (5.62 lpm/m ²)	
		Light Crude Oil	59 gpm (225 lpm)	0.06 gpm/ft ² (2.42 lpm/m ²)	
1615 ft ² (150 m ²)	96 Octane	150 gpm (570 lpm)	0.09 gpm/ft ² (3.8 lpm/m ²)		
	Condensate	150 gpm (570 lpm)	0.09 gpm/ft ² (3.8 lpm/m ²)		



Typical RE-HEALING ATC Foam Fire Test Data – Hand Line Application

Fire Conditions: EN 1568 (Parts 3 & 4)

Flammable Liquid	Solution Concentration (%)	Pan Size	Application Density gpm/ft ² (lpm/m ²)
Methanol	6	10.8 ft ² (1 m ²)	0.16 (6.5)
Ethanol (EtOH)	6	10.8 ft ² (1 m ²)	0.16 (6.5)
Acetone	6	10.8 ft ² (1 m ²)	0.16 (6.5)
Heptane	3	48 ft ² (4.5 m ²)	0.10 (4.1)

**Typical RE-HEALING ATC Foam – Tank and Dike Protection Guidelines
(Recommended Application Rates)**

Graph Category	Flammable Liquid	Tank Protection NFPA Type II		Spill and Dike Protection	
		3% ATC Solution	6% ATC Solution	3% ATC Solution	6% ATC Solution
A	Gasoline, Hexane, Heptane, VMP Naptha, n-Butanol, Butyl Acetate, MIBK, Methyl Methacrylate, Acetic Acid, Gasohol (0-20% alcohol)	0.10 gpm/ft ² (4.1 lpm/m ²)	–	0.10 gpm/ft ² (4.1 lpm/m ²)	–
B	Benzene, DMF, Methyl Acrylate, Isobutyl Alcohol, Morpholine	0.10 gpm/ft ² (4.1 lpm/m ²)	–	0.10 gpm/ft ² (4.1 lpm/m ²)	–
C	Dioxane, Ethyl Acetate, Ethyl Cellosolve, Acrylonitrile, Methanol, MEK, Ethanol, Isopropyl Ether, Ethylendiamine	–	0.16 gpm/ft ² (6.5 lpm/m ²)	–	0.16 gpm/ft ² (6.5 lpm/m ²)
D	Acetone, Isopropanol, Ethyl Ether, Tetrahydrofuran, t-Butyl Alcohol	–	0.24 gpm/ft ² (9.8 lpm/m ²)	–	0.24 gpm/ft ² (9.8 lpm/m ²)



Application Rate Guidelines for RE-HEALING ATC Concentrate

For those flammable liquids not included in the above table, the following graph can be used as a guideline determining application rates.

To use this chart, first look up the liquid's flash point and its water solubility. Determine their point of intersection and zone on the chart.

Then refer to the graph category in the above table to determine the correct application rate. (Examples of common flammable liquids are listed in each category.) Flash point and solubility data on various flammable liquids may be found in the NFPA Hazardous Materials Handbook and in other similar sources. There are some variances on category boundaries.

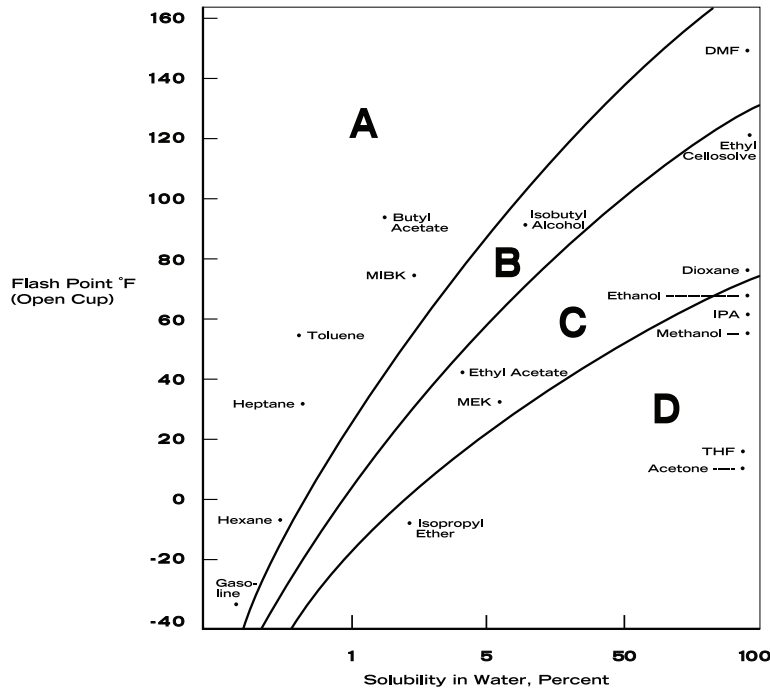

III. RE-HEALING Foam Concentrates

A. Physical Properties

RE-HEALING Foam Concentrate	Nominal Use Concentration	Specific Gravity	Viscosity, CPs.	Minimum Use Temp. °F (°C)	pH 77°F (25°C)
		77°F (25°C)	77°F (25°C)		
RE-HEALING 6%	6%	1.02	2500 Pseudoplastic Liquid	35 (1.7)	8
RE-HEALING 3%	3%	1.03	3500 Pseudoplastic Liquid	35 (1.7)	8
RE-HEALING 3x6 ATC	3%x6%	1.06	4500 Pseudoplastic Liquid	35 (1.7)	8



B. Storage and Stability

RE-HEALING foam concentrates may be stored in their shipping containers without change in their original physical or chemical characteristics. Freezing and thawing have no adverse effect on product performance, though slight stratification may result, in which case moderate agitation before use is advised.

Long term thermal aging of the *concentrates* at 150°F (65°C) has shown no adverse effect in performance. Therefore, a lifetime of at least 10 years is expected when stored in original containers. Storage of *premixes* is not generally recommended for periods beyond 5 years, and should be tested annually as required by NFPA 11.

C. Agent Testing

As recommended by NFPA 11, Section A 6.1.1.5, the foam concentrates and premix quality should be assessed annually. Assessment includes tests to determine expansion, solution strength, 25% drain time, and fire performance.

D. Water Considerations

RE-HEALING foam concentrates are designed for use with fresh, salt or brackish water.

E. Compatibility With Other Class “B”

Extinguishing Agents

Occasionally RE-HEALING foam concentrates must be applied to a fire simultaneously with protein or fluoroprotein foam. Tests have shown that RF foam concentrates can be used with either in any sequence of operation. Their use in combination detracts from the efficiency of RE-HEALING foam concentrates, but enhances the performance of protein or fluoroprotein foams.

RE-HEALING foam concentrates should not be mixed with any type of concentrates from other manufacturers.

RE-HEALING foam concentrate’s compatibility with dry chemical agents has popularized twin-agent systems. Both types of agents contribute superior knockdown; RE-HEALING foam concentrate secures against reflash while dry chemical suppresses three dimensional fires.

F. Environmental Compatibility

RE-HEALING foam concentrates are fluorosurfactant, fluoropolymer-free products for use on Class B hydrocarbon fuels with no environmental concerns for persistence, bioaccumulation or toxic break down.

IV. Materials of Construction

RE-HEALING foam concentrate is compatible with multiple materials of construction such as carbon steel, stainless steel, brass, polyethylene, and PVC. Galvanized steel should not be used in direct contact with the foam concentrate. For storage tanks, involving large quantities of concentrates, the superior rated (Code A) materials shown on Page 9 are preferred. For less material exposure or areas involving smaller amounts of agent, such as lines and valves, Code B materials are quite suitable.

The data results are based on laboratory tests which may not always exactly reproduce actual field usage conditions. Where possible, the user should perform in service tests. Dissimilar metals should be used with care, especially if aluminium components are being considered. Galvanized steel should not be used in concentrate storage service.

RE-HEALING foam concentrates will remove some paints. Spills should be flushed immediately with water. For high spillage areas certain resistant paints are identified on Page 10. Rinsing of spills is still recommended.



Recommendations for use in RE-HEALING foam systems are listed on this page in the order of serviceability (#1 through #4). Economic factors are a variable which will also influence the choice of materials for any specific application and location.

For questions about materials of construction compatibility, consult Solberg Technical Services.

Recommended Materials of Construction for Equipment Handling RE-HEALING Foam

A. Tanks

Concentrate or Premix

- #1 – 304 Stainless Steel
- #2 – Carbon Steel with Baked Phenolic Lining and certain room temperature cured coatings
- #3 – Fibreglass – Isophthalic Based Polyester with Gelpcote
- *#4 – Carbon Steel

B. Piping and Fittings

Concentrate

- #1 – 304 S.S. (small lines – 2” and under)
- *#2 – Carbon Steel (large lines – above 2”)
- #3 – “Transite” (Reg. T.M. of Johns Mansville)
- #4 – PVC (all sizes)

Premix or solution

- *#1 – Carbon Steel
- #2 – “Transite” (Reg. T.M. of Johns Mansville)
- #3 – PVC

C. Valves

Concentrate

- #1 – O.S. & Y. – Cast iron body with bronze trim and seats (large valves – above 2”)
- #2 – Ball Valve – Bronze body with 316 S.S. trim and ball (smaller valves 2” and under)

Premix or solution

All Listed and Approved fire service valves.

D. Pumps

Concentrate

	Number 1	Number 2
Casing	Cast Iron	Bronze
Impeller	Cast Iron	Bronze
Shaft	Hardened Stainless Steel	Carbon Steel
Seal	Mechanical, Crane #9	Packed

E. Gaskets

Conventional gasket materials

F. Seals and Paints

See Tables on Pages 9 and 10.

***Important:**

In certain field situations economics have dictated the use of mild steel storage containers for RE-HEALING ATC foam. If this is necessary, the user should recognize that mild carbon steel is not normally recommended for RE-HEALING ATC foam and should increase the frequency of inspection.



Compatibility of Concentrates with Metals of Construction

- A. Superior metal for construction, very little observable corrosion or sedimentation.
- B. Satisfactory metal for construction, agent can withstand exposure for at least one year, some rusting and sedimentation may occur. A yearly agent quality check is suggested when these metals are used in storage tanks.
- C. Not suitable for construction.

G. Dissimilar Metals

It is recommended that if you have dissimilar metals within your system, the interface be insulated with an inner polymeric gasket material. This gasket material typically consists of anything from polyethylene to Teflon®.*

*Teflon® is a registered trademark of E.I. Du Pont.

Metal(s)		Concentrate	Fresh Water Premix	Salt Water Premix
Aluminum	6061 T-6 Cast 356	B	B	C(pits)
Brass	CA-260 (C26000)	A	A	B
Bronze, Cast	80/10/10/ (C93700) 85/5/5/5 (C83600)	B	B	B
Copper, Electrolytic	CA-110 (C11000)	A	A	B
Copper-Nickel	90/10 (C70600)	A	A	B
Iron, Cast	SAE G-3500	B	B	B
Monel	400	A	A	B
Steel, Mild	1010	B	B	B
Steel, Stainless	304 430	A	A	C(pits)
Titanium	6AL-4V	A	A	A

Material Type	Material Name	Compatibility with RE-HEALING Foam Concentrate
Lubricants	Lupriplate® 630-2	Good
	Stavis® Aluminium Complex Grease	Good
	Marfact® All-Purpose-2 Grease)	Fair
Rubber Seals and O-Rings	EPT Synthetics	Good
	Neoprene	Fair
	Nitrile	Fair
	Butyl	Fair
Packing Materials	Metallic Crane Style 100-M	Good
Pipe Sealants (Dopes)	Fel-Pro® C5A	Good
	3M Sealer #4178	Good

Fiberglass – Approved Construction

RE-HEALING foam concentrates may be stored in fiberglass reinforced plastic tanks properly constructed with approved isophthalic based polyester resins or approved epoxy resin/fiberglass systems. Common orthophthalic polyester/fiberglass composites are not recommended nor are room temperature cured epoxy systems.

Lubricants, Seals and Packing Materials Suitability with RE-HEALING foam concentrate

The chart represents total immersion for 14 days at 120°F. (49°C.) in concentrate, fresh and salt water premixes.



Compatibility of Concentrates with Structural Plastics, Plastic Coatings, Elastomers, Lubricants, Packing Materials and Exterior Paints

Code:

- A - Superior material for equipment construction.
- B - Suitable material for long term exposure, a yearly spot check of material is advisable.
- C - Not presently recommended for equipment construction.
- * - Clear plastic samples became opaque after exposure.
- ** - Isophthalic based polyester gel cotes required over fiberglass reinforced base.
- *** - Room temperature cured epoxy systems are not recommended. Some heat cured systems, especially dicyandiamide catalyzed ones, have proven satisfactory.

Supplier Code:

- ¹DuPont Company
- ²Rohm and Hass Company
- ³Heresite and Chemical Company
- ⁴Wisconsin Protective Coating Corp.
- ⁵The Ceilcote Co.
- ⁶Sta-Vis Oil Co., Lubricants
- ⁷Fiske Bros. Refining Co.
- ⁸Crane Packing Co.
- ⁹PPG Industries
- ¹⁰Reliance Universal Inc.
- ¹¹Ashland Chemical Co.

Material Type	Material Type or Specific Identification	Suitability with:	
		Concentrate	Premix (Fresh or Salt)
Structural Plastics	Acrylonitrile-Butadiene-Styrene (ABS)	C	B
	“Delrin” [®] (acetal) ¹	B	B
	Epoxy, fiberglass-reinforced	B***	B***
	“KYDEX” [®] (acrylic-PVC alloy) ²	C	B
	Polycarbonate	B	A
	Nylon	C	B
	Phenolics, canvas-based	C	C
	Plexigls (acrylic)	B*	A
	Polyester, fiberglass-reinforced	B**	B**
	Polyethylene, high density	B	A
	Polyethylene, low density	C	A
	Polystyrene	C	A
	Polyvinyl Chloride (PVC)	A*	A
Polypropylene	B	A	
Fluorocarbon Plastics	A	A	
Baked or “Cold Set” Plastic Coatings On Mild Steel	Polyester: Flakeline [®] 252 ⁵ (50°–110° F Cure)	A	A
	Phenolic: “Heresite” [®] P-403 ³	A	A
	Phenolic: “Heresite” [®] P-413 ³	C	A
	Phenolic: “Plasite” [®] #3055 or #3066 ⁴ , 9062, 9570	A	A
	Epoxy-Phenolic (cold-set): “Plasite” [®] 7122 “Copon” ¹⁰ TL8022, “Aropol” ¹¹ 7241T-15	B	A
Elastomers	Ethylene-Propylene Terpolymer (EPT)	A	A
	Natural Rubber	B	A
	Neoprene	B	B
	Nitrile Rubber	B	A
	Nylon Reinforced Nitrile	A	A
Lubricants	Aluminum Complex Grease [®]	A	A
	“Lubriplast” [®] 630-2 ⁷	A	A
Packing Materials	Asbestos 5810 ⁸	A	A
	Metallic 100-M ⁸	A	A
Exterior Paints	“Plastite” [®] #7122 ⁴	A	A
	“Aquapon” [®] UC42207 ⁹	B	A
	“Imron” [®] Polyurethane Enamel ¹	B	A



Metals – Typical corrosion Data with RE-HEALING Foam Concentrates

Metal compatibility with Solberg RE-HEALING foam concentrates and solutions were examined by a third party testing organisation, the University Analytical Laboratory at the University of New South Wales, Australia. Testing was done to determine the corrosive effect on 14 different metals in accordance with ASTM G 31, *Laboratory Immersion Corrosion Testing of Metals*.

METHODOLOGY

Duplicate metal coupons of each of the 14 specified metals were cleaned, weighed and immersed in the following solutions for 14 days at 104±1°F (40±1°C). Testing was carried out on RF3, RF6 and RF 3x6 ATC foam concentrates and 3% or 6% solutions using distilled water.

Following immersion, the coupons were cleaned in accordance with the method ASTM D1384 *Corrosion Test for Engine Coolants in Glassware* and re-weighed. The mean weight differences in the coupons were reported. Testing was completed by the University Analytical Laboratory, University of New South Wales, Australia.

RESULTS

The mean mass loss expressed in milligrams of metal lost over the 14 day period of the test. The results are as follows:

Typical Corrosion Data with Solberg RE-HEALING Foams - Mean Mass loss over 14 days

Metal	Distilled Water	RF3% Concentrate	RF3% Solution	RF6% Concentrate	RF6% Solution	RF3x6 ATC Concentrate	RF3x6 ATC Solution
Aluminum (60/61)	8.9	0.7	0.8	0.3	0.8	0.7	0.8
Aluminum cast 356	0	1.3	0.8	0	1.5	1.3	0.8
Brass CA 260	1.4	0.5	2.0	1.7	1.6	0.5	2.0
Bronze cast 80/10/10	0	0	1.0	1.0	0	0	1.0
Bronze cast 85/5/5	0	1.1	0.6	1.1	1.1	1.1	0.6
Copper Elec CA110	3.4	0.5	0.3	0	0.1	0.5	0.3
Copper Nickel 90/10	1.2	0	0	0	0.4	0	0
Cast iron SAE G-3500	76.1	3.4	32.2	0.5	24.9	3.4	32.2
Magnesium alloy AZ31B-H24	7.7	25.3	14.9	54.0	63.2	25.3	14.9
Monel 400	0	0.5	0	0	0.5	0.5	0
Mild Steel 1010CR	51.0	4.6	33.8	3.0	24.0	4.6	33.8
Stainless Steel Grade 304	1.3	0	0.3	1.0	0.15	0	0.3
Stainless Steel Grade 430	0	0.5	0.3	0	0	0.5	0.3
Titanium 6AL-4V	1.5	0.6	0.2	0.1	1.6	0.6	0.2



Compatibility of Elastomers with RE-HEALING Foam Concentrates

Rubber and Elastomer Material Compatibility Tests On SOLBERG RE-HEALING RF3, RF6 and RF 3x6 ATC Technology FireFighting Foam Concentrates

Using ASTM Method D2240, *Test method for Rubber Property – Durometer Hardness*, the RE-HEALING foam RF3 and RF6 products and their solutions were tested for their effect on rubbers and elastomer materials.

The tests represent a total exposure time of 168 hours. The materials were Fluoroelastomer (fluorocarbon AMS3218, ASTM D2000 S6E), Natural latex (MIL-T-36966). Ethylene propylene diene terpolymer (AMS3249), Nitrile rubber (AMS3215), and Neoprene (AMS3208). Testing was completed by the University Analytical Laboratory, of the University of New South Wales, Australia.

Table 1 - Summary of Rubber and Elastomer Compatibility Test for RE-HEALING Foam Solutions and Concentrates (168 hours)

Material Description	Foam Solution or Concentration	% Change in Volume	% Change in Hardness
Fluoroelastomer	3%	-0.10	-1.22
	6%	-0.12	-0.94
	Concentrate	0.05	-2.46
Natural Latex	3%	0.22	-5.06
	6%	0.57	-6.34
	Concentrate	1.27	-4.49
EPDM Terpolymer	3%	-1.81	-1.88
	6%	-0.20	-1.37
	Concentrate	-2.21	0.24
Nitrile Rubber	3%	0.20	-0.54
	6%	0.18	-0.20
	Concentrate	0.08	-0.88
Neoprene	3%	1.88	-0.08
	6%	1.79	-0.27
	Concentrate	1.17	-0.41



AQUATIC IMPACT OF FIREFIGHTING FOAMS





Firefighters have been confused by publications on the environmental impact of Class B firefighting foams over the past 20 years. Since 1999 the information is even more confusing. The most recent challenge is the persistence of the fluorosurfactants used in Fluoroprotein Foam, AFFF, FFFP and the related Alcohol Resistant foams (AR-AFFF) that dominate the industry. The Fluorochemicals used with firefighting foam technology have been estimated to have an environmental life that could be measured in hundreds of years. In 2000, environmental concerns have initiated the development of new innovative products that contain no fluorochemicals. In 2006, information and testing was reported that fluorosurfactant containing AFFF firefighting foam concentrates had the lowest effect on fresh water fish species when compared to non-fluorosurfactant containing formulations. Testing was carried out as 96 hour tests on two fresh water fish species, rainbow trout (fingerlings) and fathead minnows (using a flow-through method) using a wetting agent, two fluorochemical free products, and three AFFF products. This was a study based on a simple acute toxicity test regime and did not reflect on any issues associated with the environmental persistence of fluorochemicals used in AFFF foams. [1]

The conclusion is that fluorine containing foams are more or less nontoxic and that the new fluorine free foams have a severe impact on the survival of fish species when we discharge these concentrates into the open water. [1] The new Fluorine Free Class B foams are based solely on synthetic hydrocarbon surfactants, which do biodegrade completely. As the synthetic hydrocarbon surfactants biodegrade, they compete with fish for dissolved oxygen, since the biodegradation process is based on aerobic oxidation decomposition. As illustrated in Table 1, the fluorosurfactant containing AFFF firefighting foams have both synthetic hydrocarbon surfactants and fluorosurfactants. They also compete with fish for oxygen as the synthetic hydrocarbon surfactants biodegrade. However, the fluorosurfactant component of AFFF foam has no immediate effect on the respiration of the fish, as it is inert and does not consume oxygen. The use of fluorosurfactants delays the impact on fish, as they are highly stable and resist biodegradation. Fluorochemicals can remain in the environment for hundreds of years, while continued use of products containing them will result in a growing back ground concentration that will eventually become significant. [2] [3] [4]

Table 1: The Chemistry of Class B (Flammable Liquid) Firefighting Foam [5]

Aqueous Film Forming Foam	= Fluorosurfactants + Organic Surfactants + Solvents* + Water
Flourine Free (Synthetic)	= Organic Surfactant + Complex Sugar + Solvents* + Water

**NOTE: Solvent = Diethylene Glycol Monobutyl Ether*



The LC50 results were reported in the publication [1] and the US Fish and Wildlife Service (FWS) classification system was applied in the following discussion. The FWS classification system was summarized in a table which we have constructed at Table 2. [1] It shows relative toxicity versus toxic dosing responses as either aquatic EC50 or LC50 (mg/L). The table is presented below:

Table 2: FWS Acute Toxicity Rating Scale [1]

Relative Toxicity	Aquatic EC50 or LC50 (mg/L)
Super Toxic	<0.01
Extremely Toxic	0.01 - 0.1
Highly Toxic	0.1 - 1
Moderately Toxic	1 to 10
Slightly Toxic	10 to 100
Practically Nontoxic	100 to 1,000
Relatively Harmless	>1,000

As previously mentioned, the testing described was carried out on two fish species: rainbow trout (fingerlings) and fathead minnows (using a flow-through method). If the FWS rating system is applied to the test results and compared in Table 3 it becomes obvious that the two fish species in this test series react slightly differently.

Table 3: FWS Acute Toxicity Rating Scale Applied to the Reported Test Results [1]

Agent	Rainbow Trout	Fathead Minnow
Wetting Agent	Moderately Toxic	Highly Toxic
Flourine-free Foam A	Slightly Toxic	Practically Nontoxic
Flourine-free Foam B	Slightly Toxic	Practically Nontoxic
US Mil Spec AFFF	Relatively Harmless	Practically Nontoxic
AR-AFFF	Relatively Harmless	Relatively Harmless
UL AFFF	Relatively Harmless	Relatively Harmless

It is interesting to note that the fathead minnow is the more sensitive to the Wetting Agent and that the Fluorine-free Foams have the same toxicity as the US Mil Spec AFFF of “practically non-toxic”. In fact the fathead minnow appeared to be the more sensitive to the fluorosurfactant based foam concentrates. Table 4 compares the LC50 of the test results. There is marked increase in the sensitivity to the fluorosurfactant based foams with the LC50 dropping to at least half of its value when compared to the rainbow trout testing. As an observation, it appears that for the Wetting Agent and the three fluorosurfactant based foams, the LC50 appears to approximately drop by 50%, making them significantly more toxic to the Fathead Minnow. Both Fluorine-free Foams experience an increase in the LC50 of >100%, showing them to be less toxic under these conditions. Figure 1 illustrates the relationship between the FWS rating system and the test results.



Table 4: LC50 Test Results for Both Rainbow Trout and Fathead Minnow Test Regimes [1]

Agent	Rainbow Trout	Fathead Minnow
Wetting Agent	1.06	0.887
Flourine-free Foam A	65	171
Flourine-free Foam B	71	171
US Mil Spec AFFF	2176	884
AR-AFFF	3536	1487
UL AFFF	5657	1726

Environmental Regulators will examine the data over a variety of species of, including fish, and will apply rating scales, such as the Acute Toxicity Rating Scale to averaged results. Rating scales are typically logarithmic and create relative categories based on other experience used to develop this scale. With reference to Table 3, all of the firefighting foams fall within the categories of Slightly Toxic to Relatively Harmless, while the Wetting Agent was found to be Moderately to Highly Toxic. With the fish species Rainbow Trout, AFFF products have a lower toxicity rating

of Relatively Harmless, while the two Fluorine Free formulations A and B have a rating of Slightly Toxic. The Fathead Minnow testing represent the acute toxicity effect to range between Practically Non-Toxic to Relatively Harmless. The two Fluorine-free products and the Mil Spec AFFF all were rated as Practically Non-Toxic. The above data show that more than one species may need to be studied. While Figure 1 illustrates the Fathead Minnow results graphically.

Figure 1: 96-Hour LC50 Flow-Through Test of Fathead Minnows [1]

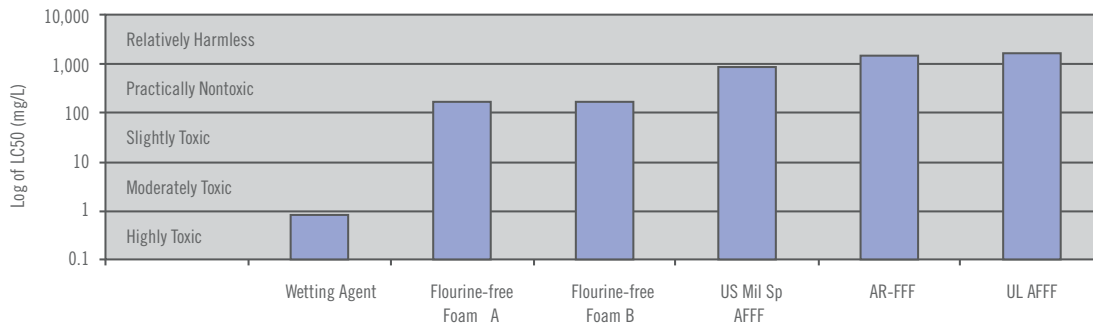



While the data was presented as a comparison of aquatic impact, it would appear that the conclusions are not as clearly defined as described in the original 2006 publication [1]. In fact there appears to be less separation between the products than first thought. Tests such as these are guidelines, but only serve as one or two inputs to a risk assessment that needs to be done by the Authority Having Jurisdiction, and this is a job best done by the Environmental Agencies. Due to the different tolerance of species, fish toxicity should be determined as an average of multiple species.

In conclusion, all firefighting foams are a mixture of chemicals. Great care must be taken to prevent accidental release of any firefighting foam concentrate into the environment. It is obvious that firefighting foams that are based on only hydrocarbon surfactants, like the Fluoro-free type, there is an immediate impact (Acute) on fish. However, the stream or river will recover over a short period of time. When fluorochemical containing foams like AFFF, FFFP or FPF, then the effect is long lasting (Chronic) due to the long environmental persistence of the fluorochemicals that will continue to build in concentration over the years effecting other inhabitants of river systems, lakes and oceans which are known to bio accumulate Fluorochemicals. We need to remind ourselves that the use of firefighting foams is very dispersive and care must be taken to minimize the release of firefighting foams, and therefore the environmental impact. [6]

References

- [1] Fire Fighting Foam Coalition (2006). "AFFF Update...Aquatic Toxicity of Fire Fighting Foams". <http://www.fffc.org/images/AFFFupdatespecial.pdf>.
- [2] Moody C.A. and Field J.A. (2000). "Perfluorinated surfactants and the environmental implications of their use in fire-fighting foams". *Env Sci Technol* 34, 3864-3870.
- [3] Lattimer B.Y., Hanauska C.P., Scheffey J.L., and Williams F.W., (2003). "The Use of Small-Scale Test Data to Characterize Some Aspects of Fire Fighting Foam for Suppression Modeling". *Fire Safety J* 38, p117-146.
- [4] Kissa E. (2001). *Fluorinated Surfactants and Repellents*. Marcel Dekker Inc., New York.
- [5] Schaefer T.H. (2002). "Class B foams...is it time to innovate?" *Proc AFAC Conf (CD Abstracts)*, Gold Coast, Australia, 48.
- [6] Klein R.A. (2009). "Contaminated Firewater – Protecting the Environment". *Fire & Rescue*, p27-29.

About the Author

At the time of publishing, Ted Schaefer was General Manager, Asia-Pacific Region for Solberg. Ted has received many industry awards and honors, and has written numerous conference papers and publications on firefighting foams that have helped raise the standards in firefighting foam technology. Ted holds degrees in General Chemistry (BSc), Chemical Technology (MChemTech) and Chemical Engineering (Meng).

BULLETIN #1009

TECHNICAL BULLETIN

RE-HEALING™ Foam Fire Performance

Introduction

In September 2011, the Fire Fighting Foam Coalition (FFFC) issued an association newsletter entitled “AFFF Update”, which compared the firefighting performance of SOLBERG RE-HEALING RF6 (6%) fluorine-free foam concentrate, against two AFFF foam concentrates currently on the U.S. Military Specifications Qualified Products List (QPL), as contained in a report presented at the 2011 SUPDET Conference in Orlando, Florida by the U.S. Naval Research Laboratories (NRL). A copy of the complete U.S. Navy report is attached to this bulletin.

The Navy report is attached, because the FFFC selectively chose various quotations from the report, to include only quotations that would cast AFFF's in the best possible light, while at the same time not including quotations where SOLBERG RE-HEALING fluorine-free foam performed equal to or better than AFFF foams. Thus the purpose of this Technical Bulletin is to clarify the fire performance of RE-HEALING RF6 foam concentrate.

It is important to recognize that Solberg has never promoted RE-HEALING foams as Military Specification (MILSPEC) compliant, or meeting the fire performance criteria of the Military Specification. In addition, it is the official position of The Solberg Company that had this analysis been conducted between the two MILSPEC foam concentrates and a non-MILSPEC, commercial grade AFFF concentrates (available from any number of foam manufacturers), the fire test results would have been exactly the same. Non-Military Specification AFFF concentrates are not formulated for MILSPEC compliance, but do comply with other recognized industry standards, such as UL, EN, IMO, which is no different than for RE-HEALING RF6 foam concentrate.

RE-HEALING Foam Fire Performance

SOLBERG RE-HEALING foam has been tested and accepted by numerous test agencies around the World. In addition, RE-HEALING foam has been tested to the LASTFIRE test protocol. LASTFIRE is a consortium of 16 oil companies, initiated in the late 1990s to review the risks associated with large diameter (greater than 40m [130 ft]) open top floating roof storage tanks. LASTFIRE stands for “Large Atmospheric Storage Tank Fires” and is managed by Resource Protection International (UK) on behalf of the oil companies.



Solberg is a global company that is a one-stop resource for firefighting foam concentrates and custom-designed foam suppression systems hardware, offering both traditional and innovative firefighting foam technology. www.solbergfoam.com



The following chart is a summation of data collected during LASTFIRE testing on a full range of fluorinated AFFF concentrates, and fluorine-free concentrates, including fluorine-free concentrates available from SOLBERG. LASTFIRE evaluates the fire performance of firefighting foams, using a point scale, where 0 is a poor performing product, and 100 is the best score achievable.

A review of the LASTFIRE test results shows that AFFF foam concentrates are not superior to the firefighting performance of RE-HEALING foam. As this chart shows, there are numerous fluorine containing foams that are poor performing, achieving very low scores (some with single digit scores), while fluorine-free foams such as those from SOLBERG routinely out-performed their fluorinated counterparts, with several achieving perfect scores of 100.

We encourage our customers to read the full U.S. Navy report. In doing so the reader will see many examples of quotes where SOLBERG RE-HEALING foam compared very favorably to their fluorinated counterparts. There are numerous quotes from the U.S. Navy report, shown in this bulletin, that are positive to Solberg products including:

"We observed that the AFFFs had diminished fire extinguishment performance with fire extinction times of 5 to 12 seconds longer in cases where they could not form film. The non-fluorinated foam performed as good as or better than the AFFFs on iso-octane."





One of the reasons for this performance is that not all fuels require film formation for extinguishment or vapour control. Additionally, AFFF foam concentrates have problems extinguishing or controlling low surface tension hydrocarbons such as gas condensate in the oil and gas industry (mainly $\leq C5$). AFFF's are also not effective on gasohol containing greater than 10% ethanol, or on fuels at elevated temperatures. As for the Military Specification, there is a revision under discussion to change the test fuel from gasoline to heptane, which will have an effect on the surface tension parameters for testing.

Effects of Surface Tension vs. Temperature

The following chart shows the effect of fuel temperature on the fuel's surface tension. In order for AFFF foam concentrates to form a film, the fuel surface tension must be greater than the AFFF surface tension – a positive spreading coefficient. This chart shows that at elevated temperatures, the fuel surface tension is less than the AFFF solution surface tension (a value of 17 dyne/cm is commonly referenced). In these cases of elevated fuel temperature, AFFF foam concentrates will not form a film as this leads to a negative spreading coefficient.

This statement in the U.S. Navy report summarizes one of the many advantages of SOLBERG RE-HEALING foam:

“Fluorosurfactants, however, are environmentally persistent, and their use in firefighting foams has led to environmental concerns.”

Table I from the U.S. Navy report is included below. SOLBERG RE-HEALING foams do not require elevated expansion levels for use, RE-HEALING foam provides excellent performance at low expansion rates. Please note, during the Navy testing expansion ratios are all in the 10:1 range, the same expansion rate as the tested fluorinated AFFF's.





Table I: Expansion Ratios and 25% Drainage Times of Foams (Mixed at Nominal Strength in Fresh Water) and Tested According to MIL-F-24385F

Foam	Expansion Ratio	25% Drain Time (s)
Foam X	9.0	262
Foam Y	9.4	360
Solberg (3M) RF6	10.3	>720 (no drainage observed)

Note: commercial names of MILSPEC AFFF's removed

It is important to note that the MILSPEC AFFF foam concentrates showed 25% drain times in the range of 262 seconds (4 minutes, 22 seconds) to 360 seconds (6 minutes). For SOLBERG RE-HEALING foam, after 12 minutes, no drainage was observed. Longer drain times lead to greater burn back resistance, which leads to greater firefighter safety.

The U.S. Navy report includes this statement, which is favorable to SOLBERG RE-HEALING foam:

"The ability for film formation does not appear to increase burnback time"

The report also includes the following information; addressing the issue of film formation of the tested AFFF agents.

"On heptane, the _____ formed a film; the _____ was able to form a film after 60 seconds, but not after 5 seconds. Therefore, although it is technically film-forming on this fuel, a film might not be able to form on the time scale relevant to the extinguishment tests."

"On iso-octane, the _____ did not form film. The _____ was able to prevent ignition in some, but not all trials. Therefore we consider the _____ AFFF as being marginal in terms of film formation for this fuel. Like the _____ on heptane, film formation may not occur on the time scale relevant to fire suppression."

Note: commercial names of MILSPEC AFFF's removed

This is important, as these two quotes call into question the premise that film formation is critical to control and extinguishment. According to the U.S. Navy report, film formation is not occurring on a time scale relevant to fire suppression!

"MIL-F-24385F specifies a fire extinction time for a standard gasoline fire of no more than 30 seconds under these test conditions. Both of the MILSPEC qualified AFFFs met this requirement easily, extinguishing the fire in slightly over 20 seconds. The RF6 foam did not meet the 30 second requirement, although it did achieve a reasonably close value of 35 seconds."

We are including this quote, because as stated earlier, the company has never implied that SOLBERG RE-HEALING foam is MILSPEC compliant. We again restate that there are numerous AFFF commercial foam concentrates on the market that will also not achieve a 30 second extinguishment because, like SOLBERG RE-HEALING foam, they are formulated to a different test standard.





The report references other test scenarios where SOLBERG RE-HEALING foam performed well:

“On iso-octane fuel, on which none of the foams were able to seal well, the AFFFs did not perform any better than the non-fluorinated RF6 foam.”

From the U.S. Navy report, the below quote concurs with our earlier statement that AFFF foam concentrates are adversely affected by elevated fuel temperatures, and how elevated fuel temperature reduces the surface tension, which then hinders film formation:

“Although not an objective of the test series, it was noted, particularly in the concurrent series of tests comparing gasoline and heptane as test fuels for the MIL-F-24385F protocol, that extinguishment performance of AFFFs on heptane fires was adversely affected by elevated fuel and ambient temperatures that were encountered during testing. Due to different temperature dependences of the surface and interfacial tensions of the AFFF/fuel system, the spreading coefficient tends to decrease slightly with temperature. Since film formation on heptane fuel is hampered by its low surface tension compared to gasoline (the spreading coefficient is close to zero [3]), even a slight further decrease with increasing temperature might hinder film formation.”

Also from the Navy report, a quote showing SOLBERG RF6 exhibiting superior fire performance to the tested AFFF's:

“For iso-octane, the non-fluorinated foam had shorter extinguishment times than the two AFFFs and was the only foam to achieve an extinguishment time under 30 seconds.”

“It is not surprising that the AFFFs tested show decreased performance on fires of fuels on which they cannot easily form film. Since their intended mode of operation assumes film formation, one would expect decreased performance in cases where film formation does not occur. The non-fluorinated, non film-forming RF6 foam, however, is designed to have mechanical properties of foam which compensate for the lack of film formation. In particular, the rate of water drainage is reduced and the foam has a lower yield stress. The shorter extinguishment times of iso-octane fires by the non-fluorinated foam compared to the AFFFs indicates that extinguishment performance in the absence of film formation can be improved by optimization of other properties of foam.

Lastly, the Navy report includes this conclusion, as number one:

The Navy report is attached, because the FFFC selectively chose various quotations from the report, to include only quotations that would cast AFFF's in the best possible light, while at the same time not including quotations where SOLBERG RE-HEALING fluorine-free foam performed equal to or better than AFFF foams. Thus the purpose of this Technical Bulletin is to clarify the fire performance of RE-HEALING RF6 foam concentrate.

“Conclusions: For the AFFF foams which were intended to work via formation of an aqueous film, fire extinction times were lengthened considerably in cases where film formation was made difficult by the low surface tension of the fuel. For the non-filming fluorine-free foam, however, no such performance decrement was observed, and the fire extinction times on the lowest surface tension fuel were lower than for fuels with higher surface tensions, and within the 30 second time limit specified (on gasoline) by MIL-F-24385F.”





In closing, attached is a copy of the U.S. Navy report, which served as the basis for the FFFC "AFFF Update" of September 2011. The Solberg Company is issuing this bulletin to provide a more balanced view of the content reported in the referenced newsletter.

The Solberg Company remains steadfast in its commitment to invest heavily in the continual progressive development of new generation of high performance firefighting foam concentrates, namely RE-HEALING RF foam concentrates, as RE-HEALING foam offers superior fire performance to AFFF under many scenarios, is environmentally responsible in that it does not contain ingredients that take decades to degrade, and RE-HEALING foam offers superior burn-back resistance and drainage times compared to AFFF foam concentrates.

FOR MORE INFORMATION

TECHNICAL BULLETIN TB-1009 | JUN 2012

COPYRIGHT © 2012. ALL RIGHTS RESERVED.
SOLBERG® AND RE-HEALING RF ARE TRADEMARKS
OF THE SOLBERG COMPANY OR ITS AFFILIATES.

UNITED STATES

10667 Jersey Blvd.
Rancho Cucamonga, CA 91730

Tel: +1 800 682 3626
Tel: +1 909 983 0772

salesfoamusa@perimeter-solutions.com

EMEA

Poligono de Baiña, Parcela 23
33682 Baiña-Mieres (Asturias)

Spain
Tel: +34 985 24 29 45

salesfoamea@perimeter-solutions.com

ASIA PACIFIC

3 Charles Street
St Marys NSW 2760 – Australia

Tel: +61 2 9673 5300

salesfoamapac@perimeter-solutions.com

Extinguishment and Burnback Tests of Fluorinated and Fluorine-free Firefighting Foams with and without Film Formation

Bradley Williams,¹ Timothy Murray,^{1*} Christopher Butterworth,^{1*} Zachary Burger,^{1*} Ronald Sheinson,^{1†} James Fleming,¹ Clarence Whitehurst,² and John Farley²

¹Combustion Dynamics, Code 6185 and ²Shipboard and Field Operations, Code 6186
Navy Technology Center for Safety & Survivability, Chemistry Division
Naval Research Laboratory, 4555 Overlook Ave. SW, Washington, DC 20375 USA

Abstract: The fire extinguishment and burnback performance of three foams were tested on four low flash point fuels: gasoline, commercial grade heptane, iso-octane (2,2,4-trimethylpentane), and methylcyclohexane. The final three fuels have flash points in a range between -9°C and -4°C, compared to gasoline which has a typical flash point of -40°C. Gasoline and heptane represent, respectively, the current and the possible future fuels for the MilSpec qualification test for AFFF. Iso-octane and methylcyclohexane were chosen because they have similar flash points but different surface tensions; AFFFs have difficulty forming film on iso-octane but can easily form film on methylcyclohexane. We observed that the AFFFs had diminished fire extinguishment performance with fire extinction times of 5 to 12 seconds longer in cases where they could not form film. The non-fluorinated foam performed as good as or better than the AFFFs on iso-octane. Significant differences were found between fuels in burnback performance (the time for fire to spread across a foam-covered pool). These fuel differences in burnback were consistent for all three foams studied, and did not correlate with fuel flash point or film formation. Other properties of the fuels, and their interaction with foam components, must be responsible for the differences in fire suppression performance. The rate of fuel passage through the foam layer measured in laboratory studies correlates with burnback performance.

*NRL Student Temporary Employment Program

† Nova Research, Inc. and Sheinson Associates, LLC

Introduction

Aqueous film-forming foam (AFFF) is widely used for fire protection against liquid fuel fires. AFFF is a type of low expansion foam, having an expansion ratio typically between 5-10. It is applied to a burning liquid pool and covers the fuel surface, inhibiting vaporization of the fuel and acting as a physical barrier between fuel and air. AFFF was initially developed for Navy aircraft carriers, and is also used extensively in civilian airports.

The film-forming property of AFFF is made possible by the presence of fluorosurfactants, which lower the surface tension enough to allow a water layer to form on top of the fuel surface. It is thought that the water layer contributes to fire extinguishment by inhibiting evaporation of fuel and percolation of fuel through the foam. Other types of surfactants are not able to achieve surface tensions as low as fluorosurfactants, and aqueous film formation has not been demonstrated for any fire fighting foams which do not contain fluorosurfactants.

Fluorosurfactants, however, are environmentally persistent, and their use in fire fighting foams has led to environmental concerns [1]. The extent to which film-forming ability is necessary for optimal fire suppression has major implications for future development of more environmentally friendly fire-fighting foams. If filming ability is critical in achieving good performance, then the only recourse for achieving the best performance is to search for fluorosurfactants which are more environmentally benign. If it is not so critical, then other options are open.

In the 2010 SUPDET, we compared AFFF behavior on fuels with flash points below and above ambient temperature. Here, we investigate the contribution of film formation to extinguishment. In a 28 ft² circular fire, following the U.S. DoD MilSpec [2] procedure, we compared two MilSpec-qualified AFFF formulations and a non-fluorinated non-film-forming foam, on fuels which have different surface tensions, so that the effect of film formation on fire extinguishment performance could be separated from other properties of AFFF.

Test Procedures and Materials

Tests were performed at the Naval Research Laboratory's Chesapeake Bay Detachment test facility during July and August, 2010. The tests conducted for this ONR program were performed in conjunction with a series of tests for NAVSEA (the AFFF warrant holder), which compared AFFF performance on gasoline with commercial grade heptane, which is under consideration as a replacement fuel for gasoline in the AFFF MilSpec qualification tests. The conjunction of the two test series allowed additional comparisons to be made between fuels for the same AFFF formulations.

All fire tests described here were performed inside a large burn room, using a 28 ft² circular pan which is used in MIL-F-24385F [2] qualification tests. The tests used a ten second preburn time (the interval between lighting the fuel and commencement of foam application) and a 2.0 gallons/minute foam application rate. Both of these parameters are identical to the MIL-F-24385F testing protocol.

The only testing parameter that was changed from the MilSpec protocol, other than the fuels used, was the total time of foam application, prior to beginning the burnback test. The MIL-F-24385F protocol calls for a total foam application time of 90 seconds, including the time for fire extinguishment. For the fuels used in this test series, this length of foam application was found to produce an unreasonably long and highly variable burnback time. Therefore, the foam application time was reduced to 60 seconds.

In addition to conjunction with the field tests, laboratory measurements of surface tension were conducted using a Du Nuöy Ring tensiometer.

Fuels Tested

The following fuels were used in the field tests.

Gasoline (non-ethanol containing, unleaded)

This is the fuel currently used for MIL-F-24385 qualification tests. It typically has a flash point near -40°C. The measured surface tension of this fuel at an ambient temperature of 23°C was 23.7 dynes/cm.

Iso-octane (2,2,4-trimethylpentane, 99% minimum, Chevron-Phillips)

This fuel has a very low surface tension (measured value of the fuel as tested was 18.7 dynes/cm at 23°C) and it is difficult for even MilSpec AFFFs to film on it. The flash point of this compound is -7°C.

Methylcyclohexane (MCH), 99% minimum, Chevron-Phillips)

This fuel has a relatively high surface tension (measured value of the fuel as tested was 23.6 dynes/cm at 23°C), so AFFFs will easily film on it. The flash point of this compound is -4°C.

Heptane (commercial grade, isomeric mixture, Shell)

This fuel is used for AFFF qualification under the UL testing protocol, and is being considered for use in the MIL-F-24385 testing. The sample used in the field tests had a measured surface tension of 20.0 dynes/cm at 23°C. The flash point of the material used (manufacturer's data for the lot) is -9°C.

Foams Tested

Three foam formulations were used in testing. For all tests, the foam concentrate was mixed at its nominal concentration (6% for Type 6, 3% for Type 3) in fresh (tap) water.

-National Foam (now sold by Kidde Fire Fighting) Aer-O-Water 6-EM: A Type 6 AFFF concentrate (intended to be mixed at 6% concentrate and 94% water) which has been qualified against the MilSpec MIL-F-24385F.

-Buckeye Fire Equipment Company BFC-3MS AFFF: A Type 3 AFFF concentrate (intended to be mixed at 3% concentrate and 97% water) which has been qualified against the MilSpec MIL-F-24385F.

-Solberg (originally 3M) RF6 Foam: A non-fluorinated, and hence non-film forming, foam which NRL has previously tested. On gasoline it takes a slightly longer time for flame extinguishment than AFFF (about 40 seconds, compared to 30 seconds MilSpec requirement) [3]. Comparing the performance of this foam to that of the AFFFs on isooctane, on which none of the foams form a film, allows us to assess whether the AFFFs have other properties, besides film formation, that contribute to suppression.

Table I: Expansion Ratios and 25% Drainage Times of Foams (Mixed at Nominal Strength in Fresh Water) and Tested According to MIL-F-24385F

Foam	Expansion Ratio	25% Drain Time (s)
National Foam 6-EM	9.0	262
Buckeye BFC-3MS	9.4	360
Solberg (3M) RF6	10.3	>720 (no drainage observed)

Properties of the foams produced by the concentrates when discharged through the "standard" nozzle used in MIL-F-24385F testing have been measured in previous testing in our laboratory. The measurement procedure to determine the expansion ratio (foam volume/volume of liquid contained in the foam) and drainage time (time for 25% of the liquid contained in the foam to drain) of foams is specified in MIL-F-24385F. For the three concentrates mixed at their nominal concentrations in fresh water, the expansion ratio, and 25% drainage times measured according to this procedure are given in Table I. The minimum values required for qualification are an expansion ratio of 5:1 and a drain time of 150 seconds. All three foams used in this test series have similar expansion ratios near 10:1. The RF6 foam has a much slower drainage than the AFFFs, due to the presence of polysaccharides in the concentrate.

Film Formation and Sealability Test Results

The ability of AFFF to form an aqueous film on a hydrocarbon pool is governed by the spreading coefficient [4]:

$$\text{Spreading Coefficient} = \sigma_{\text{fuel}} - \sigma_{\text{AFFF}} - \gamma_{\text{fuel-AFFF}}$$

where σ_{fuel} and σ_{AFFF} are the surface tensions of the fuel and the AFFF solution, respectively, and $\gamma_{\text{fuel-AFFF}}$ is the interfacial tension between the two. The two surface tensions are on the order of 15-20 dynes/cm, while the interfacial tension is in the range of 2-4 dynes/cm. The MilSpec protocol requires determination of the numerical value of the spreading coefficient (must be at least 3 dynes/cm on cyclohexane fuel), as well as a "practical" test of film formation. In MIL-F-24385F [2], cyclohexane is the fuel used for both tests.

Film formation and sealing tests (from the MIL-F-24385F protocol, Section 4.7.6) were conducted on the fuel/foam combinations. The test procedure involves covering a fuel surface with foam, then displacing the foam by inserting a wire screen funnel and scooping out residual

foam, so that the fuel surface can be covered by an aqueous film layer (if one is present), but no foam. After waiting 60 seconds, the operator attempts to ignite the fuel surface with a small butane flame that is placed approximately ½ inch above the surface. An inability to ignite the fuel surface indicates successful film formation (which inhibits fuel vaporization). If the fuel surface can be ignited, this means that a film has not formed.

For MIL-F-24385F qualification testing, cyclohexane is the fuel used. Cyclohexane has a high surface tension (24.5 dynes/cm, higher than any of the fuels tested here). Therefore, use of cyclohexane as the fuel is not a very stringent test of an AFFF's film forming ability. In the present study, heptane, methylcyclohexane, and iso-octane were used. Whether the foams are able to form film on the test fuel is important at interpreting the fire extinguishment data given below.

An additional test conducted, if film formation after 60 seconds were successful, was to disturb the fuel surface to disrupt the film layer, then attempt ignition after approximately five seconds. This indicated how rapidly a film layer could form--60 seconds is twice the allowable extinguishment time for full strength AFFF in the MIL-F-24385F protocol. The ability of AFFFs to form film after a longer length of time, but not after a short time interval is a consequence of dynamic surface tension. In a surfactant solution, the surface tension slowly approaches the equilibrium value (the static surface tension). An AFFF with a spreading coefficient which is only very slightly positive on a given fuel may not be able to form a film [5,6] if its dynamic surface tension is not able to approach the equilibrium value quickly enough.

The results of the film formation and sealability tests, as well as surface tension measurements for the fuels, are given in Table II. In these tests, ignition means that film did not form; no ignition means that film did form. As expected, the non-fluorinated RF6 foam was unable to form a film on any of the fuels tested. Both of the AFFF foams formed film on MCH, which has a high surface tension. On heptane, the Buckeye Type 3 formed a film; the National Type 6 was able to form a film after 60 seconds, but not after 5 seconds. Therefore, although it is technically film-forming on this fuel, a film might not be able to form on the time scale relevant to the extinguishment tests.

Table II: Film Formation and Sealability Test Results				
Fuel	Fuel Surface Tension (dynes/cm)	Foam		
		National Type 6	Buckeye Type 3	RF-6 (Type 6)
Iso-octane	18.7	No film	Marginal ¹	No film
Heptane	20.0	Marginal ²	Film	No film
MCH	23.6	Film	Film	No film
Gasoline	23.7	Film Expected	Film Expected	No Film Expected

¹ Fuel was ignited on some, but not all, attempts.

² No ignition occurred after waiting 60 seconds for film to form, but ignition occurred after a 5 second wait time.

On iso-octane, the National Type 6 did not form film. The Buckeye Type 3 was able to prevent ignition in some, but not all trials. Therefore we consider the Buckeye AFFF as being marginal in terms of film formation for this fuel. Like the National Type 6 on heptane, film formation may not occur on the time scale relevant to fire suppression.

Fire Suppression Test Results

The times required to extinguish the fire by foam application are shown in Table III. Two values on a particular entry in the Table indicates multiple tests were performed. The fire fighting protocol followed the MIL-F-24385F procedure. The foams were mixed at their nominal strength in fresh (municipal) water and the mixture was applied at a flow rate of 2.0 gallons/minute from the nozzle specified by MIL-F-24385F, following a 10 second preburn interval between ignition and the beginning of foam application.

MIL-F-24385F specifies a fire extinction time for a standard gasoline fire of no more than 30 seconds under these test conditions. Both of the MilSpec qualified AFFFs met this requirement easily, extinguishing the fire in slightly over 20 seconds. The RF6 foam did not meet the 30 second requirement, although it did achieve a reasonably close value of 35 seconds on one of the tests. In general, the non-fluorinated foam tended to show more test to test variability in fire out times than the AFFFs. This is consistent with the lack of film formation making the extinguishment of the last remnant of the fire more difficult (flames tend to flare up again if the firefighter's technique is not optimal). This greater sensitivity can be attributed to the lack of a film, which suppresses fuel volatilization in areas uncovered by foam.

Based on the ability of the two AFFFs to qualify for the MilSpec and the measured surface tension of the gasoline sample, we expect the National and Buckeye AFFFs, but not the RF6 foam, to be able to form a film on gasoline.

Table III: Fire Out Time (s)				
		Foam		
Fuel	Fuel Surface Tension (dynes/cm)	National Type 6	Buckeye Type 3	RF-6 (Type 6)
Iso-octane	18.7	32,33 (no film)	32,33 (marginal film)	29,30 (no film)
Heptane	20.0	23,28 (marginal filming)	25 (film)	43 (no film)
MCH	23.6	22,23 (film)	19,20 (film)	33, 46, (no film)
Gasoline	23.7	22 (film expected)	21 (film expected)	35,41 (no film)

All of the tests performed on fuel/foam combinations on which good sealing occurred showed fire out times of no more than 25 seconds. By contrast, with one exception (National Type 6 on heptane), all of the tests performed on fuel/foam combinations where no, or only marginal,

sealing occurred, showed fire out times of at least 29 seconds. On iso-octane fuel, on which none of the foams were able to seal well, the AFFFs did not perform any better than the non-fluorinated RF6 foam. Thus it appears that film formation does indeed contribute to good AFFF fire extinguishment performance by 20%.

There does not appear to be a significant influence of flash point on foam suppression performance between the fuels tested. National and Buckeye AFFFs both had similar extinguishment times for MCH and gasoline, in spite of a large difference in flash point. It should be noted that all of these fuels have flash points significantly below ambient temperature, so this trend will not necessarily apply to fuels with flash points above room temperature.

Burnback (Re-ignition) Test Results

Burnback tests were conducted according to the procedure described in MIL-F-24385F. After extinguishment is achieved in the tests described above, the foam application is continued, building up a foam layer that will be challenged for reignition. For the standard MIL-F-24385F tests on gasoline, the total time of foam application (including the time to extinguish the fire) is 90 seconds. After completion of the foam application, a 1 ft. diameter pan filled with burning fuel is placed in the middle of the 6 ft diameter burn pan. Fig. 1 shows the firefighter placing the starter pan at the beginning of the burnback test.



Figure 1: Firefighter placing the started pan in the foam-covered fuel at the beginning of the burnback test

There is no direct contact between the starter pan fuel and the fuel or foam in the main burn pan. Heat release from the starter pan fire erodes the foam and in the case of low flash point fuels, ignites vapors which penetrate the foam layer. Eventually, the fire ignites outside the starter pan and spreads across the main burn pan. When the fire is judged to be self-sustaining outside the starter pan, the starter pan is removed. The burnback time is defined as the time interval from

placement of the starter pan until the fire re-involves 25% of the main burn pan. The MIL-F-24385F requirement for burnback is a time of at least 360 seconds for full strength AFFF.

In comparing test results for heptane done for the rebaselining of the MilSpec test procedure done concurrently with the tests reported here, it was discovered that heptane fires exhibit a much longer burnback time than gasoline. In order to give a reasonable and reproducible test result for the burnback time, it was decided that the foam application time for heptane fires should be reduced to 60 seconds from 90 seconds. The burnback times observed for heptane at 60 seconds foam application were longer than for gasoline at 90 seconds foam application. Comparison of two tests with National Foam AFFF with 90 second and 60 second application times show a burnback time approximately 80 seconds longer for the 90 second foam application.

Because iso-octane and methylcyclohexane have similar flash points to heptane, a 60 second foam application was used on these fuels as well (with the exception of one test of RF-6 foam in which a 45 second foam application was used). Results of the burnback tests are given in Table IV.

Fuel	FOAM		
	National Type 6	Buckeye Type 6	RF-6 (Type 6)
Iso-octane	767	820	789 ¹
Heptane	878 ¹ , 758	674	563
MCH	522	499	503
Gasoline	652 ²	657 ²	512 ²

¹ 45 second foam application

² 90 second foam application

All three foams displayed longer burnback times on heptane than on gasoline even for a foam application time that was 30 seconds shorter. There were also substantial differences in burnback between fires of heptane, iso-octane, and methylcyclohexane, even though these three fuels have very similar flash points. MCH fires exhibited the shortest burnback times for all three foams tested, and iso-octane the longest. This large difference in burnback times was unexpected, given the similarity in flash points. Also, the burnback times do not correlate with filming ability. Isooctane has the lowest surface tension among the fuels tested but exhibited longer burnback times than methylcyclohexane or gasoline, which have higher surface tension and filming ability. It suggests that the key factor governing burnback times for fuels with flash points below ambient temperature may not be either the flash point or the filming ability, but rather other differences between fuels which influence the rate of vapor penetration through the foam.

Discussion of Field Test Findings

Extinguishment times for gasoline and methylcyclohexane fires by AFFF were about 20 seconds for AFFF solution at nominal strength, using fresh water. This compares to a requirement of 30 seconds under MIL-F-24385F. The similar extinguishment times for these two fuels indicate

that the lower flash point of gasoline compared to MCH does not greatly affect extinguishment times.

On the other hand, fuel/foam combinations on which filming did not occur or was difficult (the non-fluorinated foam formulation for all fuels, and iso-octane with the two AFFF foams), showed extinguishment times ranging from approximately 30-40 seconds. On heptane, the AFFFs formed film, although in one case sealing did not occur within a few seconds. In terms of extinguishment, heptane was found to be an intermediate case, giving extinguishment times a few seconds longer than for gasoline fires, but shorter than the iso-octane fires, for both AFFFs tested.

Although not an objective of the test series, it was noted, particularly in the concurrent series of tests comparing gasoline and heptane as test fuels for the MIL-F-24385F protocol, that extinguishment performance of AFFFs on heptane fires was adversely affected by elevated fuel and ambient temperatures that were encountered during testing. Due to different temperature dependences of the surface and interfacial tensions of the AFFF/fuel system, the spreading coefficient tends to decrease slightly with temperature. Since film formation on heptane fuel is hampered by its low surface tension compared to gasoline (the spreading coefficient is close to zero [3]), even a slight further decrease with increasing temperature might hinder film formation.

For iso-octane, the non-fluorinated foam had shorter extinguishment times than the two AFFFs and was the only foam to achieve an extinguishment time under 30 seconds. Based on this observation, it is tempting to ascribe a major role in extinguishment to film formation. There appear to be other factors at work, however. The non-fluorinated foam had substantially better performance on iso-octane than on any of the other fuels. This is not explained by film formation, which did not occur for any of the fuels for this foam.

It is not surprising that the AFFFs tested show decreased performance on fires of fuels on which they cannot easily form film. Since their intended mode of operation assumes film formation, one would expect decreased performance in cases where film formation does not occur. The non-fluorinated, non film-forming RF6 foam, however, is designed to have mechanical properties of foam which compensate for the lack of film formation. In particular, the rate of water drainage is reduced and the foam has a lower yield stress. The shorter extinguishment times of iso-octane fires by the non-fluorinated foam compared to the AFFFs indicates that extinguishment performance in the absence of film formation can be improved by optimization of other properties of foam.

An unexpected observation was the substantial difference in burnback times between the fuels. Since all of the model fuels (heptane, iso-octane, and methylcyclohexane) have very similar flash points, it was expected that they were likely to show similar burnback behavior to one another, but somewhat longer burnback times than for fires of gasoline, which has a lower flash point.

In fact, methylcyclohexane had similar burnback performance to gasoline, while the other two fuels had much longer burnback times, indicating better foam performance. This trend, while varying somewhat in magnitude, was consistent across all three foams tested. The ability for film formation does not appear to increase burnback time. In fact, iso-octane, on which film

formation is the most difficult, had the longest burnback times of any of the fuels tested. The present series of tests do not provide an immediate explanation for this finding. Laboratory studies to measure the rate of fuel transport through the foams were carried out to determine whether fuel differences in vapor penetration could account for the observed differences in burnback times.

Laboratory Studies of Vapor Penetration Through Foams

One of the roles of foam in preventing reignition, particularly on fuels with flash points below ambient temperature, is to prevent / inhibit the vaporization of fuel to form a flammable mixture with air that can be reignited. That fuel passage through the foam contributes to reignition is apparent from field tests in which transient flames sweep across the foam during burnback, indicating a flammable vapor concentration, but not maintained in steady state. (Fig. 2).

Previously, Moran et al. investigated fuel vaporization suppression by AFFF aqueous film in the absence of foam [6]. Schaefer et al. [7] compared the time for a flammable mixture to form above foams of RF6, other non-fluorinated formulations, and an AFFF formulation. Previous studies have not included a systematic comparison between fuels. The significant differences observed in burnback times in the field tests discussed above indicates that fuel differences are significant in foam performance.

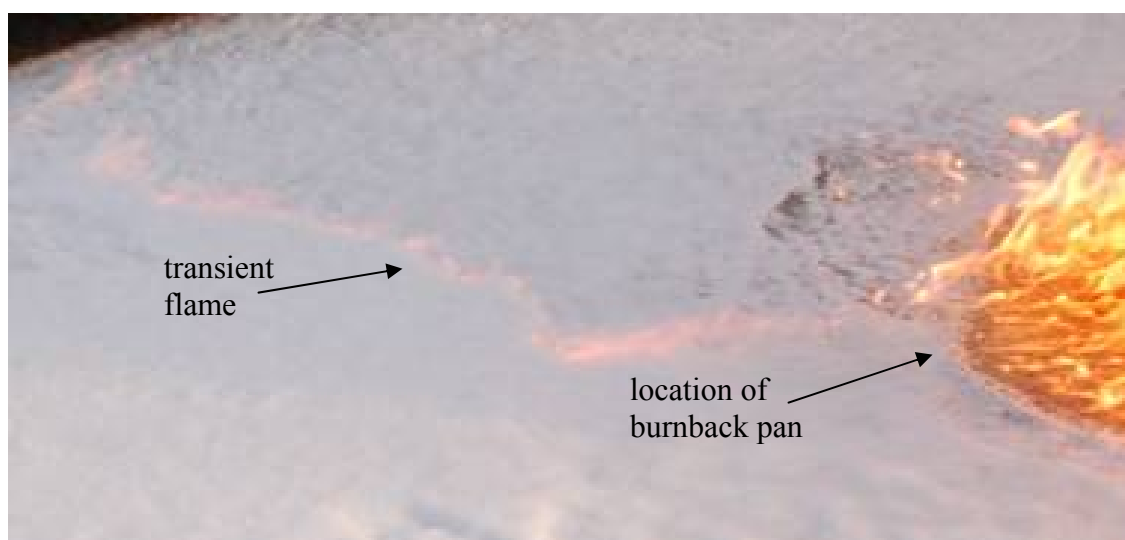

Fig 2: Transient flames observed during burnback test, demonstrating a flammable air/fuel mixture created by fuel vapor passage through the foam.

In the present series of tests, we investigate the rate of steady state fuel vapor transport through the three foams investigated in the field tests, on iso-octane, heptane, and methyl-cyclohexane.

Experimental Setup and Methodology

To quantify vapor passage through foam for different fuel/foam combinations, we constructed a laboratory apparatus to study the passage of vapor through foams and aqueous films. The design, shown in Fig. 2, largely follows the design of Leonard and Burnett [4]. A nitrogen carrier gas passes through a porous frit in a stagnation flow geometry into a container containing fuel covered by film and/or foam. The nitrogen carrier gas picks up fuel vapor, and the mixture is analyzed in real-time by an FTIR spectrometer (Midac Corp.), which monitors the concentration of the fuel in the carrier gas.

For data collection, the foam is prepared and covers the fuel. The foam is generated by air

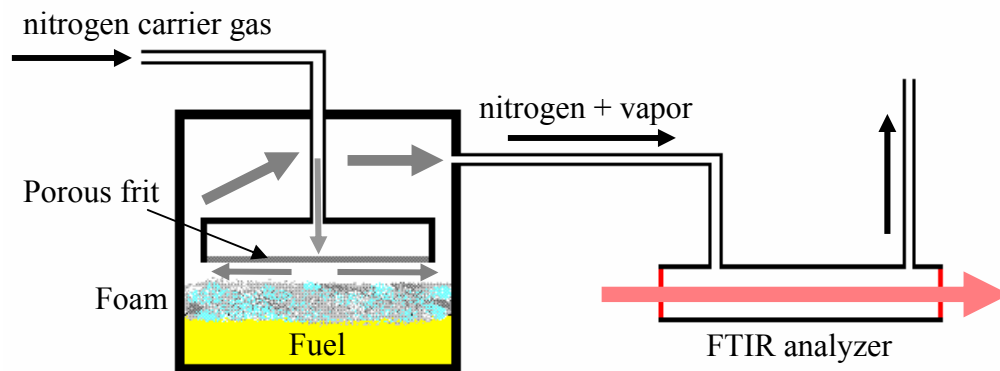

Fig. 3: Schematic of Vapor barrier test set-up.

sparging, rather than by the aspirated nozzle used in the field tests. Due to the small volume of foam required for the laboratory studies, the nozzle used in the field tests would not be practical. The expansion ratios of the foams generated by air sparging used for the vapor penetration studies were, however, similar to the values obtained with the field equipment given in Table I.

Data from a typical run, using heptane fuel, foam produced from Buckeye Type 3 AFFF, and nitrogen carrier gas, are shown in Fig. 4. The IR spectrum, which contains absorption features due to heptane, water and carbon dioxide, is shown, along with a concentration vs. time plot of the analytes.

The data are analyzed by taking the steady state equilibrium concentration as a function of the carrier gas flow rate. At steady state, the amount of fuel vapor passing into the IR cell (vapor concentration \times total gas flow rate) is equal to the fuel mass transfer rate from the pool to the gas. The data are plotted (Fig. 5) as the vaporization rate per unit area ($\text{gm}/\text{cm}^2\text{-s}$) vs. the ratio of the actual vapor concentration compared to the saturated vapor concentration. The measurements give a linear relationship, which reaches zero for saturated vapor, and can be extrapolated to the evaporation rate at a negligible vapor concentration.

Fig. 5 also compares the rate of fuel volatilization in the presence of Buckeye Type 3 AFFF foam to the rate in the absence of foam. Under this test condition, the fuel volatilization rate is reduced by approximately a factor of 50 by the presence of the foam.

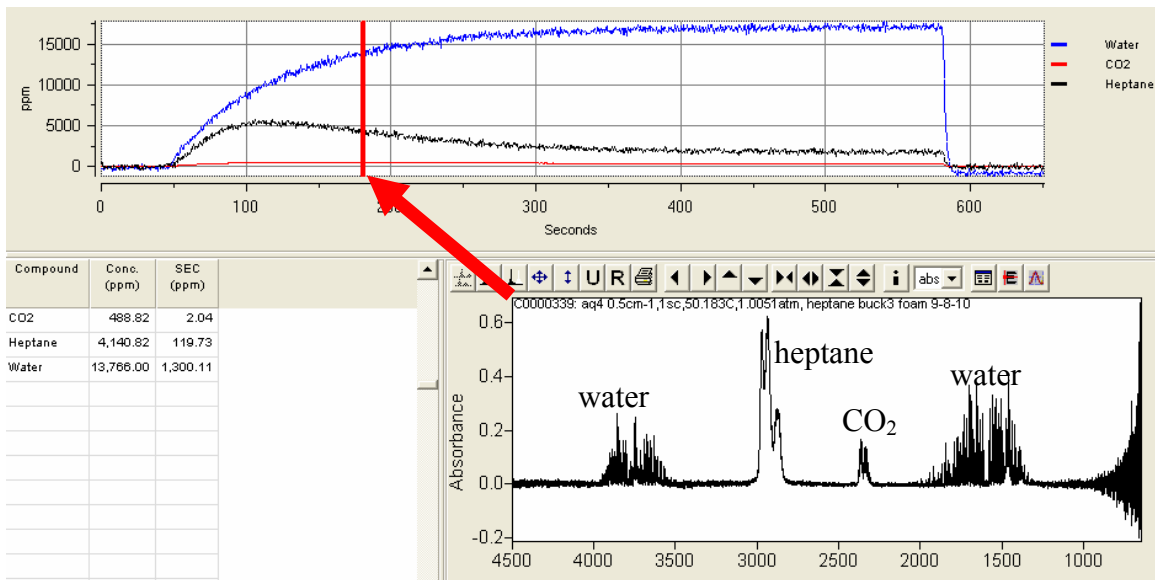

Fig. 4: IR spectrum and concentration versus time plot of heptane vapor penetrating through AFFF. Line on concentration graph indicates time corresponding to spectrum

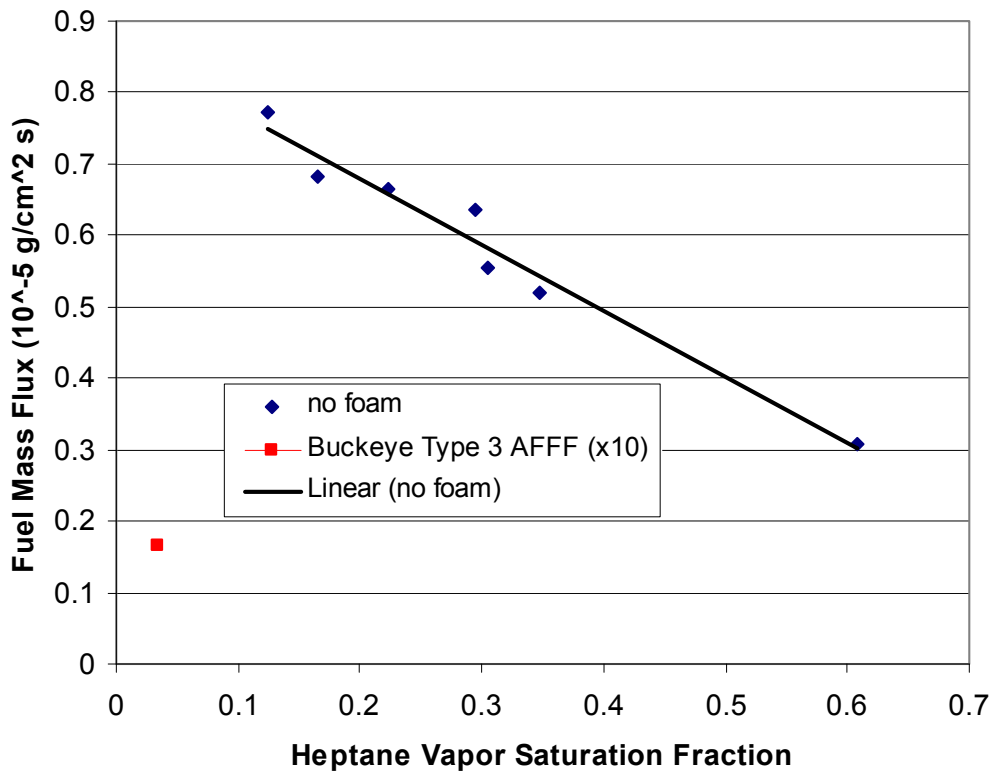

Fig. 5: Comparison of mass flux rates in the presence and absence of foam. The foam reduces the fuel volatilization by approximately a factor of 50.

Results for Different Fuel/Foam Combinations

We measured the reduction in fuel volatilization by foams for all the fuel/foam combinations investigated in the field tests described in Sections 2 and 3. These measurements clarify the role of fuel penetration through foams in explaining the differences in burn back times observed for fuels with similar volatilities.

Results for the steady state vaporization rate for the different foam/fuel combinations, and for each fuel without foam, are given in Table V. The porous plug standoff distance, and carrier gas flow rate, are held constant in this series of experiments. The effect of each foam inhibiting fuel volatilization is characterized by a Foam Blockage Factor (ratio of vaporization rate without foam to rate with foam). A blockage factor of one means the foam does not inhibit volatilization at all; a factor of infinity means that no vapor penetrates the foam.

The blocking factors range from roughly 5 to 20, with significant differences between fuels. Methylcyclohexane has the lowest blocking factor for all foams, and iso-octane the highest for two of the three. It is noteworthy that the ordering of the fuels by blocking factor is the same as the fuels' ordering by burnback times in the field tests.

Figure 6 plots the burnback times observed in the field tests (60 seconds foam application except in the case of the RF6/iso-octane combination, which had a 45 second foam application). The correlation coefficient between the two quantities is 0.82, indicating that the rate of fuel vapor transport through the foam has a significant influence on burnback.

Table V: Steady State Vapor Concentrations and Foam Blockage Factors

Foam	Fuel					
	Iso-octane		Heptane		Methylcyclohexane	
	vapor conc.	blockage factor	vapor conc.	blockage factor	vapor conc.	blockage factor
none	20900		28800	---	14600	---
National	950	22.0	2450	11.8	1400	10.5
Buckeye	1400	14.9	1750	16.5	2850	5.1
RF6	950	22.0	2700	10.7	1900	7.7

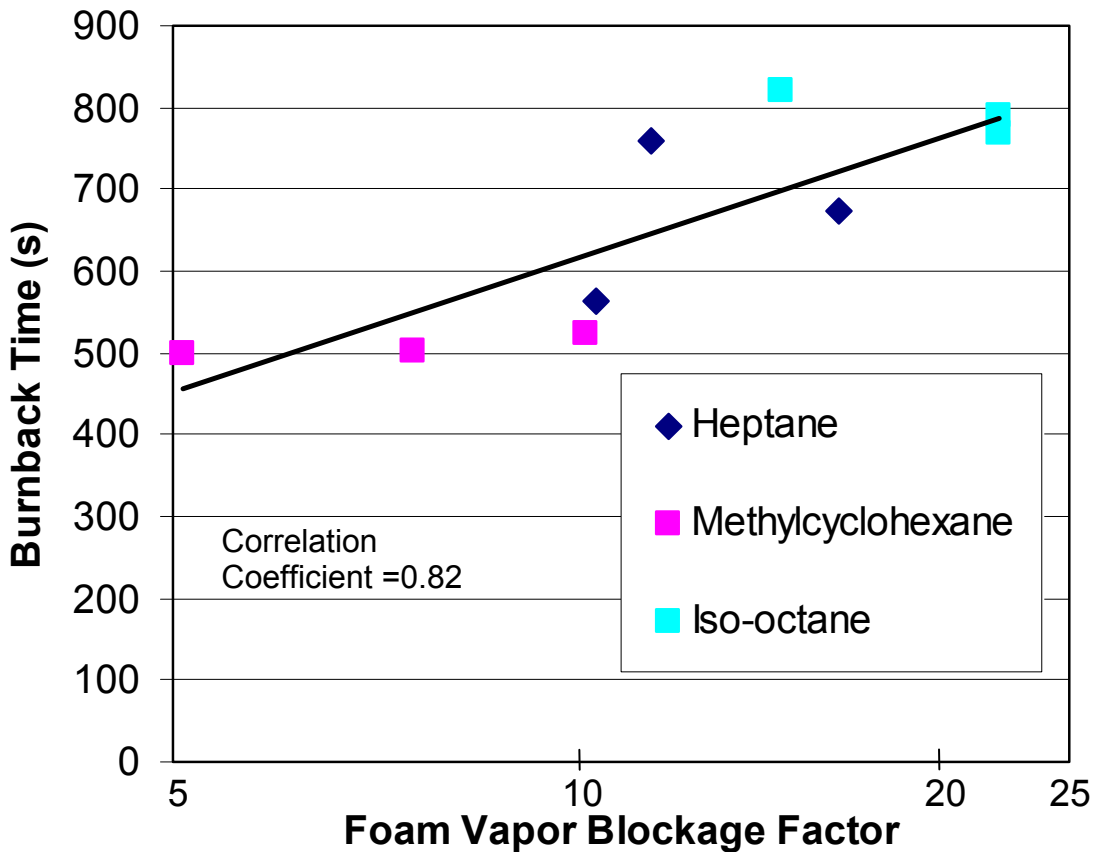

Fig. 6 Dependence of burnback time in field tests on the foam vapor blockage factor (ratio of steady state fuel vapor concentration without and with foam) measured in laboratory experiments.

Conclusions

For the AFFF foams which were intended to work via formation of an aqueous film, fire extinction times were lengthened considerably in cases where film formation was made difficult by the low surface tension of the fuel. For the non-filming fluorine-free foam, however, no such performance decrement was observed, and the fire extinction times on the lowest surface tension fuel were lower than for fuels with higher surface tensions, and within the 30 second time limit specified (on gasoline) by MIL-F-24385F.

An unexpected observation was the substantial differences in burnback times between fuels, which were fairly consistent across foams. Since all of the model fuels (heptane, iso-octane, and methylcyclohexane) have very similar flash points, it was expected that they were likely to show similar burnback behavior to one another, but somewhat longer burnback times than for fires of gasoline, which has a lower flash point.

In fact, methylcyclohexane had similar burnback performance to gasoline, while the other two fuels had much longer burnback times, indicating better foam performance. This trend, while

varying somewhat in magnitude, was consistent across all three foams tested. The ability for film formation does not appear to increase burnback time. Iso-octane, on which film formation is the most difficult, had the longest burnback times of any of the fuels tested.

Laboratory studies to measure the rate of fuel transport through the foams indicate that foam/fuel systems which better inhibit fuel passage through the foams are associated with longer burnback times. This finding intuitively makes sense, because the primary mechanism of burnback for low flashpoint fuels is vapor passing through the foam layer. However, the mechanisms of fuel transport through the foam, and the influence of fuel and foam composition, remain to be determined.

This work was supported by the Office of Naval Research under Contract # N0001410AF00002

References

1. C. A. Moody and J. A. Field, "Perfluorinated surfactants and the environmental implications of their use in fire-fighting foams," *Environ. Sci. Technol.* 34, 3864-3870 (2000).
2. "Military Specification: Fire Extinguishment Agent. Aqueous Film-Forming Foam (AFFF) Liquid Concentrate", For Fresh and Sea Water" MIL-F-24385F, Naval Sea Systems Command, 7 January 1992.
3. R. S. Sheinson and S. Ayers, "Fire Fighting Performance of Fluorosurfactant-Free Alternatives to Aqueous Film Forming Foam (AFFF): Initial Evaluation of 3M RF6 And A Developmental Formulation," *NRL Letter Report 6180/0303* (2004).
4. J. T. Leonard and J. C. Burnett, Suppression of Evaporation of Hydrocarbon Liquids and Fuels by Films Containing Aqueous Film Forming Foam (AFFF) Concentrate FC-196, *NRL Formal Report FR-7842*, December 31, 1974.
5. E. K. Hyland and B. A. Williams "Characterization of the Dynamic Surface Tension of Aqueous Film-forming Foam", *NRL/MR/6180-04-8749*, February 9, 2004.
6. Moran, H.E., Burnett, J.C., and Leonard, J.T., "Suppression of Fuel Evaporation by Aqueous Films of Fluorochemical Surfactant Solutions", *NRL Formal Report, FR-7247*, April 1, 1971.
7. T. H. Schaefer, B. Z. Dlugogorski, and E. M. Kennedy, Sealability Properties of Fluorine-Free Fire-Fighting Foams (FfreeF), *Fire Technol.*, 44, 297-309 (2008).



TECHNICAL BULLETIN

Fluorine Free Foam — Not All Concentrates Are Equal

Solberg, a leading global manufacturer of firefighting foam concentrates is proud to announce and be the first foam manufacturer to achieve Underwriters Laboratories, Inc. (UL) Standard 162 Listing for RE-HEALING™ (RF) foam. RE-HEALING foam concentrates are formulated using a new high performance synthetic foam technology that is completely free of all fluorinated compounds, be it fluorosurfactant, fluoropolymers, or any other organohalogens.

This statement is fully substantiated by independent laboratory analysis, including achievement of the challenging *Harmonized Offshore Chemical Notification Format (HOCNF)* analysis of Solberg fluorine-free concentrates for use in the North Sea. HOCNF testing involved detailed chemical analysis of SOLBERG RE-HEALING finished product, in addition to every raw material used in the production of RE-HEALING foam, to prove that RE-HEALING concentrates contain no fluorine, chlorine, or other organohalogens.

And so it was with great interest when an alleged competing fluorine-free product stated to be “*the first and only fluorine free, UL listed foam...*” in an advertisement (shown below) at the recent 2013 Fire Department Instructors Conference in Indianapolis, Indiana.





Chemguard ECOGUARD is a specially formulated, synthetic fluorine free fire-fighting foam concentrate based on an innovative patented polymer surfactant, low-toxicity hydrocarbon surfactants, and other non-hazardous ingredients. As a result, it is substantially biodegradable and presents the lowest environmental impact of any UL listed Class B fire-fighting foam.

As an AFFF and Fluoroprotein foam alternative, this advanced formulation produces similar fire-fighting performance as AFFF and Fluoroprotein products while containing no organofluorine components. When used in systems and handline applications, ECOGUARD produces a strong and cohesive foam blanket on the surface of the fuel to extinguish fire and suppress fuel vapor.

ECOGUARD is intended for use at a proportioning rate of 3% for top-side / handline applications and select sprinkler applications on Class B hydrocarbon type fuels such as gasoline, kerosene, diesel, etc. It is also intended for use at a proportioning rate of 6% for various other sprinkler applications.

ECOGUARD is to be used on hydrocarbon fuels only.

FEATURES

- UL Listed, "Foam Liquid Concentrates"
- GB15308-94 Approved
- Meets EN1568 Fire Test Criteria
- Because of its superior environmental impact properties, this product is ideally suited for municipalities and fire departments.
- Suitable for use with either fresh, brackish, or sea water when properly proportioned and applied.

- Contains no fluorosurfactants or organofluorine.
- Suitable for use with aspirating foam nozzles.
- Suitable for use with certain deluge and closed head foam water sprinkler systems.
- Suitable for use with carbon steel, fiberglass, polyethylene or stainless steel. Chemguard ECOGUARD is not compatible with galvanized pipe or fittings in an undiluted form.
- UL recommended application rate on hydrocarbon type fuels is 0.16 gpm/ft².
- Follow manufacturers' recommendations for proportioning

PROPORTIONING

Chemguard ECOGUARD is designed for use with the following types of foam proportioning equipment.

- In-line balanced pressure and pump pressure-proportioning skid.
- Bladder tank balanced pressure-proportioning systems.
- Around the pump proportioning equipment.
- Handline, air-aspirating nozzles with fixed eductor pickup tube.
- Fixed or portable in-line educators.
- ECOGUARD is *not* designed for premix applications.

In our review of the ECOGUARD® product data sheet, this product is described as an “*advanced formulation produces similar firefighting performance as AFFF and Fluoroprotein products while containing no organofluorine components.*” These published claims of organofluorine free foam, and the first and only fluorine free foam were worthy of further investigation.

The development of ECOGUARD foam concentrate was presented in a technical/industry paper titled “AFFF Fire Performance Without Fluorosurfactant? Yes...With High Molecular Weight FluoroPolymers”, at the Reebok Joint IFE/JOIFF Conference on December 20, 2004, at the Reebok Stadium in Bolton, Greater Manchester UK. The paper was presented by Dr. Kirtland P. Clark, at the time the Vice President R&D for Chemguard, Inc.

This paper presented the fire performance of ECOGUARD foam concentrate, along with details on how the product was formulated. On slide 6 of this presentation, the presenter states “*What is Chemguard FluoroSurfactant Free Foam (FSFF)? It has an effective amount of at least one high molecular weight polymer with perfluorinated side chains optimized to stabilize bubbles to Class B fuels.*” (Underlining added by Solberg).





What is...

Chemguard FluoroSurfactant Free Foam (FSFF)?

ECOGUARD 3% & 3%AR

- It is a synthetic foam which has no fluorosurfactant, but meets the UL 162 Class B fire test, both topside and sprinkler, at the same rate as an AFFF agent.
- In January 2003, completed UL listing fire tests on 3% and 3% AR products at 0.04 and 0.06 gpm/ft² rates.
- Chemguard applied for a broad based patent on FluoroSurfactant Free and low fluorosurfactant content foams in 2001, defining a wide range of covered polymers and surfactant compositions
- It has an effective amount of at least one high molecular weight polymer with perfluorinated side chains optimized to stabilize bubbles to Class B fuels.

The use of a high molecular weight polymer with ***“perfluorinated side chains”*** is NOT a fluorine free foam concentrate. Perfluorinated materials are, by definition and their description, fluorine containing materials.

On Slide 19 of the same presentation, the presenter states *“Combining 3% F3 and FSFF Technologies Provides AFFF Type Fire Performance Without Fluorosurfactants and Polysaccharides. Strong performance with less than 0.20% fluorine as Chemguard FP-5102 (High Molecular Weight FluoroPolymer) and 4-6% Chemguard HS-100. Not sensitive to solvent as is the 3% F3 product, yet does not contain fluorosurfactants or polysaccharides.”*





**Combining 3%F3 and FSFF Technologies
Provides AFFF Type Fire Performance
Without Fluorosurfactants and
Polysaccharides**

Provides exceptional fire extinguishing and burnback properties, even in tap water; equal to or better than many AFFF agents.

Strong performance with less than 0.20% fluorine as Chemguard FP-5102 (High Molecular Weight FluoroPolymer) and 4-6% Chemguard HS-100.

Not sensitive to solvent as is the 3% F3 product, yet does not contain fluorosurfactants or polysaccharides.

Without polysaccharide, has viscosity like water and storage and heat stability equivalent to AFFF agents; >20 years.

In this statement, the presenter is stating that the product is free of fluorosurfactant, but NOT free of fluoropolymer. To the contrary, the presenter is stating the fluorine content of this finished product.

Lastly, on Slide 26, the presenter states “*FluoroSurfactant Free Foam (FSFF) Requires High Molecular Weight Polymer (HMWFP).*” The presenter is clearly stating that in his view, the product requires high molecular weight fluoropolymer to perform in fire situations.





Compare Low Fluorine Foam Alternatives	
<u>AFFF Based Foam Agents</u>	<u>FluoroSurfactant Free Foam (FSFF)</u>
Modest agent cost	Cost ~50% greater than AFFF
Requires fluorosurfactant(s)	Requires High Molecular Weight Polymer (HMWFP)
Aqueous film aids in obtaining rapid control and extinguishment	Stabilized bubble covers liquid giving slower control and extinguishment
Good burnback properties	Excellent burnback properties
Allows US MIL Type performance	Too slow for US MIL Type Agent but meets UL 162 AFFF 2gpm/3min.
Insensitive to application device	More sensitive to application device since good bubble is necessary

In the presentation, the formulation chemist responsible for the development of this supposed fluorine free foam concentrate (ECOGUARD) identifies how this product was developed; by substituting “fluorosurfactant” with high molecular weight “fluoropolymers”.

Call it what you may, the use of fluoropolymers in a foam concentrate does not qualify as “fluorine free”. This Reebok presentation regarding the formulation work of the ECOGUARD foam concentrate does not describe a product identified in marketing literature as *“the first and only fluorine free, UL listed foam...”* or an *“advanced formulation (that) produces similar firefighting performance as AFFF and Fluoroprotein products while containing no organofluorine components.”*

The Solberg Company’s line of RE-HEALING foam concentrates contain no fluorine of any kind, or any organohalogens, whether described as fluorosurfactant, high molecular weight fluoropolymer, or any other description used to describe fluorine chemistry. The Solberg Company also has the third party documentation, from the German Institute of Hygiene to verify our statements that RE-HEALING foam is completely free of fluorine or other organohalogens as both a finished product, and on each and ingredient used in our product.

Our recommendation to perspective users of fluorine-free firefighting foam concentrates is to conduct proper due diligence and beware of marketing claims regarding other fluorine free foam products.



PERIMETER-SOLUTIONS.COM

UNITED STATES
 1520 Brookfield Avenue
 Green Bay, WI 54313
 Tel: +1 (920) 593-9445
 salesfoamusa@perimeter-solutions.com

EMEA
 Polígono Industrial de Baiña
 Parcela 23
 33682 Baiña-Mieres (Asturias)
 Spain
 Tel: +34 985 24 29 45
 salesfoamemea@perimeter-solutions.com

ASIA-PACIFIC
 3 Charles Street
 St Marys NSW 2760
 Australia
 Tel: +61 2 9673 5300
 salesfoamapac@perimeter-solutions.com

BULLETIN #1013

TECHNICAL BULLETIN

Fluorine Free Foams — Fact vs. Fiction

INTRODUCTION:

The Solberg Company has identified a technically inaccurate and misleading research test report and corresponding published news article that are damaging to the reputation of Solberg.

The news article and Danish technical test report were conducted and funded by a fluorosurfactant manufacturer opposed to fluorine-free foams. This would not imply independence in the preparation of the article or the referenced report. Please also note that during the testing; no fluorine containing AFFF-type foams were tested to the same test program, to serve as a benchmark to measure other firefighting foam products.

It is the opinion of The Solberg Company that the test study and the conclusions reached in it, along with the published news article, are technically flawed, baseless and without merit. The technical accuracy would certainly not survive a peer review by technical competent experts in this field of study. As such, Solberg offers the following corrective comments related to these reports:

BACKGROUND:

The technical report produced and entitled “*Fluorine Free Foam (F3) Fire Tests - May 2012*” was conducted at the Falck Nutec Training Centre in Esbjerg, Denmark. The report was commissioned by Resource Protection International at the request of Dynax Corporation with logistical support from Dafo-Fomtec.

The news article entitled “*Independent Evaluation of Fluorine Free Foams (F3) – A Summary of ICAO Level B & EN 1568 Fire Test Results*” was published in the September 2012 Edition of Asia Pacific Fire. The author of the article was also Dynax Corporation.



The fire testing as conducted is stated to be compliant to the International Civil Aviation Organization (ICAO) Level B testing protocol. However, the actual testing is not in accordance with the ICAO test protocol. Deviations observed to the established protocol include:

- A. The report references multiple tests involving fuels that are not part of the ICAO test protocol. The ICAO protocol calls for 100 litres Jet 1A (Avtur) only¹, and does not test on fuels such as heptane. Implying ICAO Level B testing results with the incorrect fuel(s) is deceiving.
- B. The report references the use of a “MMS” nozzle, described as a modified military specification nozzle. Any of the fire tests performed using this non-recognized modified nozzle are irrelevant, as this nozzle is not recognized by EN or ICAO² Standards. Documenting any fire performance based on this nozzle as having any relevance to ICAO, EN, or any other fire test standard is not applicable.
- C. There is no description regarding the process used to create the foam solutions used in the fire testing. The report does state that the specific gravity was not taken into account in the preparation of the foam solutions used in the tests. This is an erroneous procedure and calls into question whether the products were actually tested at the required 3% or 6% solutions.
- D. In the report, none of the test equipment or test fuels had any required certification(s) identified or listed, a process mandated by recognized fire test laboratories.
- E. The report references the use of forceful application of the foams onto the fuel surfaces. Forceful application of foam is not a part of the ICAO Level B fire test protocol, stating otherwise is misleading and inappropriate.

Reference is made to work conducted that identified SOLBERG® RE-HEALING™ foam as flammable³. The author is stating that users of Solberg fluorine-free products will be applying flammable foam to a fire. This statement is false and is completely without merit, and damaging to The Solberg Company and its reputation.

Noted below are photographs of fire testing conducted by Solberg; witnessed by Underwriters Laboratories and conducted in accordance to UL 162 (Standard for Safety for Foam Equipment and Liquid concentrates) on a typical UL Listed AFFF foam concentrate. The UL Listed foam concentrate is manufactured using fluorosurfactant used by Solberg and several other fluorinated firefighting foam manufacturers.

¹ Airport Services Manual p. 32 §8.1.5 Fire Test Method (c)

² Airport Services Manual p.31 Table 8.1 requires the use of a UNI86 foam nozzle run at a nozzle pressure of 700 kPa

³ Dr. Chang Jho, Dynax Corporation “Flammability & Degradation of Fuel-contaminated Fluorine Free Foams” International Fire Fighter November 2012, 36, pp.41-44





Please note in the photographs, the foam blanket is on fire. This picture was taken at the beginning of the burn back testing period as is typical of all AFFF foam agents. This burning foam blanket is expected by UL, and is not factored into the decision as to whether a foam concentrate will be UL listed or not.

In the cited report, Table 17 on Page 20 represents that the results are according to ICAO Level B. These results are not ICAO Level B compliant tests due to numerous deviations from the published test protocol.

This report purports to be an independent test report, but then states on Page 13 that:

“...It should be noted here that whilst Fomtec scored the majority of these tests in agreement with RPI and under their supervision, test 19 and 21 (Fomtec foam) and tests 31 and 33 were scored directly by RPI....”

Fomtec, a competing foam manufacturer, should not under any circumstances be issuing foam test ratings on the fire performance of competing foam agents in a supposedly impartial test program. How this can be considered an impartial test of a particular foam agent is hard to understand.

The fire test facility used for the testing, Falck Nutec, is a training facility, and is neither a recognized approval testing body nor does the facility issue approval certificates for any ICAO or EN tested foam products.

The supposedly impartial evaluation of fluorine free foams against an ICAO Standard does not include any testing of any fluorine containing foam agents. Without proper controls using a fluorinated product to establish a comparative baseline against the currently approved ICAO foam products the results are anything but impartial or relevant to ICAO.





In Paragraph 3.3 on Page 18, the report states that:

"...These tests were performed following the test methodology provided in ICAO Airport Services manual Part I Rescue and Fire Fighting 3rd Edition: 190 Chapter 8, Fire Test Method. In each case the foam solution was prepared using potable water with Jet-A1 (Gropasol D40) as the fuel..."

This statement regarding the preparation of foam solutions is not true, as shown in Table 5 on Pages 9 and 10 of the report cited.

The submitted article for publication includes numerous inaccurate statements, including:

1. *"Despite individual attempts by some foam manufacturers in the past, F3 agents have rarely been subjected to an independent evaluation under the same test conditions."*

SOLBERG foam products have received ICAO Level B Approval for sale to airports around the World by recognized independent test laboratories. In Solberg's case and unlike the report documents, the ICAO test requirements were followed. Certificates documenting the successful testing to the actual ICAO test requirements can be provided upon request.

A statement is made by the articles' author that for ICAO level B, moving the nozzle is not appropriate or allowed by ICAO Level B. This is a false statement⁴.

2. *"Dynax, as the sponsor of this project, commissioned Resource Protection International (RPI) to provide independent third party witnessing service for the fire tests according to ICAO Level B and EN 1568 (Part 3 and 4)."*

The testing was not performed according to the requirements of ICAO, as documented earlier (test fuel, altered nozzles, etc.). EN test requirements were also ignored by using altered non-protocol-compliant test nozzles.

3. *"RPI are uniquely qualified to witness such tests as they have sitting members on the NFPA and EN Foam Technical Committees, as well as being LASTFIRE testing coordinators and LASTFIRE steering committee members. Dafo-Fomtec and Falck Nutec provided logistical support."*

RPI is not uniquely qualified for this work. The facility used in Denmark is not a certified test laboratory. SOLBERG current ICAO and EN product approvals have all been performed by (and obtained from) certified and recognized test laboratories across Europe. Further, Dafo-Fomtec is a direct competitor of Solberg, and assisted in evaluating and assigning test results, which is inexcusable.

⁴ See Airport Services Manual §8.1.5 p.32 under "Test Procedure" paragraph 1, i.e., "...Position the chamber holding premix foam upwind of the fire with the nozzle horizontal at a height of 1 m above the upper edge of the tray and at a distance that will ensure that the foam will fall into the centre of the tray. The branch pipe may be moved on a horizontal plane during the test..."





4. *“In May of 2012 a series of 38 fire tests were carried out with five different Fluorine Free Foam (F3) agents by the Danish Fire Laboratories (DFL) at the outdoor fire testing and training facilities of Falk Nutec in Esbjerg, Denmark. ICAO Level B and EN 1568 tests were conducted in fresh water.”*

As documented earlier, ICAO test procedures were not followed. And as also stated prior, the Falck Nutec facility is not a certified test laboratory, nor does the facility issue EN or ICAO test reports.

5. *“Confirm if the selected group of F3 agents meet, under the same test conditions, the requirements of ICAO Level B and EN 1568 (Part 3 and 4).”*

ICAO and EN test standards were not followed; stating that the testing complied with these standards is not accurate.

6. *“Compare the above test results obtained with the UNI 86 nozzle (the nozzle specified in ICAO and EN 1568 Parts 3&4) with results obtained with a Modified air-aspirating US Mil-Spec (MMS) nozzle providing the same nominal flow rate as the UNI 86 nozzle but approximately half the foam expansion and drain time values. The results of these comparative fire tests are considered important, because many commercial air-aspirating foam discharge devices, such as handline nozzles, branchpipes and high flow turrets, generate foams with considerably lower expansion and drain time characteristics than those obtained with the UNI 86 nozzle.”*

Results obtained with a non-compliant field modified nozzle, which is neither recognized nor included in the stated fire test protocols, is inappropriate; it would not be allowed in fire testing for either ICAO or EN Approvals. Conclusions made as a result of the testing are invalid.

7. *“...prior R&D work done at Dynax has shown that F3 foams surprisingly become flammable when contaminated with fuel. This detrimental effect of fuel contamination is expected to be more severe in direct and forceful applications as seen in aviation applications than in gentle applications.”*

This statement is completely inappropriate as addressed earlier and as shown in the photographs. Solberg is manufacturer of both fluorinated and fluorine free foam products. During Solberg’s extensive testing of fluorine containing foams as part of the company’s product UL listings, it is routine for fluorine containing foams (i.e., foams of the AFFF-type containing fluorosurfactant as well as hydrocarbon surfactant) to experience flame flashover, commonly referred to as ‘ghosting’, during the burn back test portion of the testing program. This type of foam is far more flammable than results show in UL fire testing and listing work for Solberg fluorine free foams. The flammability of AFFF shows the ghosting fires typically involve the complete foam blanket. During the same test protocol with UL for SOLBERG fluorine free foam (i.e. RE-HEALING Foam), no ghosting fires occur, the fires are self-extinguished during the burn back testing portion of the fire test protocol.





For the UL Listing of RE-HEALING RF6, 6% fluorine-free foam Solberg conducted seven (7) burn back tests on the same foam blanket, one consecutively after another. Every one of the 7 burn back tests self-extinguished, even though the test standard only requires a single burn back test; Solberg considered it important for UL to witness multiple self-extinguishments, since RE-HEALING Foam technology is new, and Solberg chose to erase all doubts about the quality and extinguishing capability of the company's products. This is not an example of flammable foam, unlike the fluorinated counterparts. The authors of the flammability statement offer no proof, no supporting documentation, when making this false and damaging statement. None of this work on the supposed flammability was witnessed or documented by any outside approval agency or laboratory.

8. *"As expected, test results showed variability between manufacturers. In general, the foams tested showed reasonable fire control but suffered persistent edge flicker fires so they failed to extinguish at all, or only extinguished with considerable difficulty."*

When the requirements of a known and published test Standard such as ICAO or EN are not followed, none of the results from the testing are or can be considered relevant.

9. *"Of particular interest were the results obtained from the ICAO Level B testing (Table 1), because a few airports and aerodromes have recently started using F3 agents in lieu of AFFF or FFFP agents. These tests showed that none of the F3 agents extinguished the fire within the maximum 60-second time limit specified in the ICAO Standard. Contrary to the expectation that the sloppier foam obtained from the MMS nozzle might provide a faster knockdown and extinguishment on Aviation Kerosene (Jet A1), control times actually got longer with the MMS nozzle in two out of the three tests, and in both of these cases extinguishment was not achieved."*

This is an unfounded and damaging attack against Solberg, RE-HEALING Foam products and Solberg current customers that use RE-HEALING foam products. Again, the ICAO testing requirements were not followed so the test results are baseless and without merit. Unlike the authors, Solberg has achieved product ICAO Level B Certificates by using certified, recognized third party test laboratories.

10. *"In all cases, the control and extinguishment times extended considerably as the UNI 86 nozzle was switched to the MMS nozzle delivering foams with more realistic characteristics. It is noted that none of the agents achieved a IA forceful application rating (Table 2). Even under the gentle application conditions (Table 3), some F3 foams failed to extinguish the fire when the MMS nozzle was used."*

The EN 1568 Standard requires the use of a specific test nozzle, the prior mentioned UNI 86 nozzle. Testing with an unrecognized and undocumented altered test nozzle created by Dynax has no merit in evaluating fire performance or in determining compliance to the Standard.





11. *“The F3 agents tested showed differences in fire performance between manufacturers and fuel types. Most agents suffered from persistent edge flicker fires causing problems meeting the extinguishment requirements. The results of these tests with a higher foam expansion UNI 86 nozzle and a lower foam expansion MMS nozzle show that fire-fighting effectiveness decreases with the foam quality. The foam expansion and drain time values from the MMS nozzle are more realistic of the foam quality typically obtainable from real world air-aspirated discharge devices.”*

The Companies that were targeted with this poorly conducted test program have no knowledge what this MMS nozzle is or looks like or how it has been modified. Solberg does know that it is not a recognized device from the referenced product testing standards. Testing with this device has no merit and has no bearing whatsoever on an approved product.

12. *“Of most alarming concern is the complete failure of the F3 agents to pass ICAO Level B performance requirements. A few airports and aerodromes have recently converted away from the conventional fluorine-containing foam agents such as AFFF and FFFP to F3 agents. It is known that two of the five tested products claiming ICAO Level B certification are currently used at some airports and aerodromes. If their ARFF vehicles are using non-aspirating turrets and handlines, the concern over the use of F3 agents is even greater”*

Solberg possesses valid test certificates for ICAO Level B performance from internationally recognized test agencies. For the authors to state that based on their erroneous testing, that SOLBERG RE-HEALING foam products do not pass ICAO Level B is without merit. This is an unfounded attack on the quality and reputation of The Solberg Company and its affiliates.

13. *“The failure of F3 foams to perform under forceful application conditions in both ICAO Level B and EN 1568-3 appears to be related to fuel contamination effects that are expected to be more pronounced under direct, forceful application conditions. Foams generated from the MMS nozzle are heavier and therefore expected to pick up more fuel than the lighter but unrealistic foams produced by the UNI 86 nozzle.”*

Reference to a ‘forceful’ application is not a part of the ICAO test procedure, showing again how the ICAO test procedures were not followed, whereby statements made in the article describing ICAO testing should be ignored. This paragraph then continues discussion of a MMS nozzle which again, is not a recognized test apparatus according to either EN or ICAO test standards, so that any results achieved with this device should be ignored and not published in a discussion of EN or ICAO standards.

14. *“Five F3 agents were independently evaluated and compared under the same test conditions against the fire performance standards of ICAO Level B and EN 1568.”*





As Solberg stated earlier, test protocols for neither ICAO nor EN 1568 were followed, with products receiving a 'grade' from a competitor.

15. *".....All failed to meet the ICAO Level B test requirements. Against EN 1568-3, none of the products met the IA class ratings under direct, forceful application conditions: some achieved the ratings only with indirect, gentle applications. Significant deterioration of fire-fighting performance was observed when the MMS test nozzle was used delivering foams with quality more realistic of widely used foam turrets and handlines."*

Again, test protocols for neither ICAO nor EN Standards were followed, and the MMS nozzle is not a recognized device by either Standard document and therefore has no relevance.

SUMMARY:

This bulletin describes some of the technical inaccuracies contained in the subject report and article. In Solberg's opinion the subject report and article are filled with inaccurate statements, numerous technical deficiencies and distortion of facts, often based on mere supposition without any supporting evidence.

In conclusion, (a) the work was not performed in accordance with the ICAO Standard test procedure while stating otherwise; (b) the work was not performed at a recognized fire test laboratory experienced in ICAO or EN Standard test procedures and requirements; (c) the work involved improper and unrecognized test apparatus (such as the referenced MMS nozzle); and (d) the results were determined not by the test site but rather by a vendor supplier and competitor of the tested foams. Copies of the news article and fire test report are available upon written request at info@solbergfoam.com.

FOR MORE INFORMATION

TECHNICAL BULLETIN TB-1013 | APR 2013

COPYRIGHT © 2013

UNITED STATES

10667 Jersey Blvd.
Rancho Cucamonga, CA 91730

Tel: +1 800 682 3626

Tel: +1 909 983 0772

salesfoamusa@perimeter-solutions.com

EMEA

Poligono de Baiña, Parcela 23
33682 Baiña-Mieres (Asturias)

Spain

Tel: +34 985 24 29 45

salesfoamemea@perimeter-solutions.com

ASIA PACIFIC

3 Charles Street
St Marys NSW 2760 – Australia

Tel: +61 2 9673 5300

salesfoamapac@perimeter-solutions.com

BULLETIN #1011

TECHNICAL BULLETIN

Foam Systems — Discharge Test Check List

INTRODUCTION:

The following check list provides guidance to ensure that the filling and testing of your SOLBERG foam system eliminates any delays or additional expenses (that may be associated with the foam system discharge/commissioning test), as well as, accomplishing these steps in a safe, economic and expedient manor.

PRIOR TO INSTALLATION:

Be certain that all foam concentrate proportioning equipment to be installed matches the project specifications and your purchase order. In the event there are discrepancies, contact Solberg immediately. Check the tank capacity(s), equipment type and size along with the electrical operating voltages of the equipment, if applicable.

SYSTEM DESIGN CONSIDERATIONS DURING INSTALLATION:

- Is the ratio controller mounted at the same elevation as the top flange of the bladder tank?
- Is there a minimum of 5 pipe diameters of straight unobstructed pipe on the inlet and outlet to each ratio controller?
- If the system utilizes a variable range proportioner does the equivalent feet of pipe between the bladder tank and proportioner exceed 35 feet (10m)?
- Foam solution piping has been thoroughly flushed and cleaned of all dirt and debris?
- Hydraulic calculations have verified a maximum 2 p.s.i. (0.14 bar) pressure differential between the water inlet pressure and the foam concentrate inlet pressure at the ratio controller?
- A drain or other suitable means of removing water and foam/water solution from the foam equipment room must be provided.
- Manual control valves, check valves and automated valves (if provided or required) must be installed in their proper locations. A manual valve with visual position indicator **MUST** be installed in the foam concentrate piping as close to each foam concentrate tank connection point as possible. A check valve **MUST** be installed in the foam concentrate supply pipe near each ratio controller (proportioner).
- All components (check valves, proportioners and strainers) sensitive to flow direction must be installed in the piping system in the proper position.



- ***ABSOLUTELY NO INTERNALLY GALVANIZED OR INTERNALLY COATED PIPE MAY BE USED FOR FOAM CONCENTRATE SERVICE.***

- Note: NFPA 11 (Standard for Low, Medium, and High Expansion Foam) specifically prohibits galvanized piping for foam concentrate service. It is acceptable to use galvanized or coated pipe for distribution of the foam/water solution only.
- All piping must be adequately supported at the connection points to foam concentrate tank(s). This is particularly important for polyethylene foam concentrate (i.e. atmospheric) storage tanks.

PRIOR TO SCHEDULING DISCHARGE TEST:

- Arrangements must be made in advance of the day scheduled for the test of the foam system. Failure to comply with this requirement will result in additional costs.
- The foam solution flow for each foam system must fall within the minimum and maximum foam solution flow ranges supported by the ratio controller (proportioner) in the foam system supply pipe or riser. In most cases, attempting to achieve success by flowing foam solution from a ½ inch (13mm) inspectors test connection or other small discharge outlet will not allow sufficient flow for the proportioning equipment to function properly. If the foam system cannot be discharged into the hazard area, a special test header may have to be fabricated to properly discharge the required flow. If a test header is required, it must be installed and functional prior to the test date.
- The Authority Having Jurisdiction (AHJ) [i.e. fire marshal, insurance underwriter, code official, etc.] must be contacted to discuss the details of the tests that they require for acceptance testing. Acceptance

test criteria are specific to a particular installation. Test criteria are normally established by the AHJ or in some cases are defined in the Contract Documents / Project Specifications.

- A firm date and time for the tests must be set at this time. Solberg does not always set the system test parameters; this is usually under the control of the AHJ.
- A practical arrangement for foam solution distribution or disposal must be made. This is normally the responsibility of the Installing Contractor or the End-User. Discharged foam/water solution can be channelled to a Waste Water Treatment Plant or to an Environmental Waste Disposal Company. Check with the local Waste Water Treatment Plant to determine if they can (or will) accept the foam solution discharge. Consult www.solbergfoam.com (Technical Documentation) if additional copies of the MSDS (Material Safety Data Sheet) for the foam concentrate utilized are required.
- If the foam system requires water-pumping equipment to perform properly, this equipment must be functioning properly prior to the day of the foam system test. Arrangements (with others) to test the water supply (if necessary) must therefore be made in advance of the foam system test.
- A power supply of 120 vac/1phase/60 Hz with GFI protection (other voltages for locations outside the U.S. may be required) must be available during the day(s) of the tank fill and test. In some cases air driven fill pumps are used, but the power sources; electricity or air, must be readily available to drive the foam concentrate fill pump.
- For Pump Skid type systems only, proper three (3) phase electrical power, in accordance with NFPA 20 (Standard for the Installation of Stationary Fire Pumps) must be connected to the foam concentrate pump motor controller(s).





- If the foam concentrate pump is diesel driven, make sure enough diesel fuel is provided for the testing of the complete foam system.
- Filling of the foam concentrate tank will require several hours for equipment setup and actual fill. This process should not be interrupted once it has begun. Appropriate
- Scheduling and timing must be accomplished prior to the day the tank is to be filled.
- Verify water supply available.
- Verify electrical contractor furnished (if applicable).
- All personnel required to witness the foam system test should be contacted and reminded of the scheduled date and time of the discharge test.

DAY OF TEST:

- In order for discharge tests to run smoothly and without unnecessary delays it is important to have a clear understanding of what will be required. The test requirements are specific to a particular installation and are generally established by the AHJ (fire marshal, insurance underwriter, code official, etc.) or contract documents.
- Solberg will require the contractor to provide the following equipment and/or services necessary for conducting the discharge test:
- A water supply with a garden hose connection must be available in the immediate vicinity of the foam concentrate tank to facilitate tank fill and/or equipment clean up.
- Foam concentrate containers must be placed within the vicinity of the foam concentrate storage tank(s).
- Arrangements must be made for disposal of empty foam concentrate containers. Solberg is not responsible for remove these containers from the premises.

- Wet dry shop vacuum, minimum 3 hp.
- Pitot tube.
- Assure appropriate material moving (fork lift, man lift, pallet jack) equipment is onsite and operational.
- Assure necessary extension cord(s), hand tools, step ladder(s) are onsite.
- Test manifold with necessary number of hose outlets, or discharge sample port.
- Necessary sections of fire hose(s) with the required number of hose monster(s) are onsite.
- **DIAPHRAGM (BLADDER) TANK SYSTEM ONLY:** Depending on the filling method used, a vacuum cleaner, compressor, nitrogen or dry air may be required during the day of the tank fill.
- **PUMP SKID TYPE SYSTEMS ONLY:** Ensure that the electric power supply to the foam concentrate pump motor controller(s) is available and functioning properly.
- **PUMP SKID TYPE SYSTEMS (WITH DIESEL POWERED FOAM CONCENTRATE PUMP) ONLY:** The diesel fuel tank must be filled with diesel fuel and all fluid levels (water and oil) must be checked and serviced as necessary. The batteries must have a full charge and in a "ready to run" condition.
- The diesel pump controller will charge the batteries if connected to an appropriate power supply with adequate time prior to the system fill and test day.

FAILURE TO ACCOMPLISH THE APPROPRIATE ITEMS INDICATED WITHIN THIS CHECKLIST PRIOR TO THE TIME OF THE SYSTEM FILL & TEST DATE COULD RESULT IN A DELAY. LENGTHY DELAYS AND/OR RESCHEDULING COULD RESULT IN ADDITIONAL CHARGES BEING IMPOSED BY SOLBERG.





FOR MORE INFORMATION

UNITED STATES

10667 Jersey Blvd.
Rancho Cucamonga, CA 91730
Tel: +1 800 682 3626
Tel: +1 909 983 0772
salesfoamusa@perimeter-solutions.com

EMEA

Polígono de Baiña, Parcela 23
33682 Baiña-Mieres (Asturias)
Spain
Tel: +34 985 24 29 45
salesfoamemea@perimeter-solutions.com

ASIA PACIFIC

3 Charles Street
St Marys NSW 2760 – Australia
Tel: +61 2 9673 5300
salesfoamapac@perimeter-solutions.com



SECTION 3
INTRODUCTION

Fire Tetrahedron

Foam extinguishes flammable liquid or combustible liquid fires in four different ways:

- Separates the flames from the fuel surface
- Retards vapor release from the fuel surface
- Cools the fuel surface and any surrounding metal surfaces
- Excludes oxygen from the flammable vapors

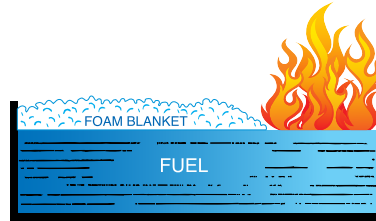

Classes Of Fire (America)

The National Fire Protection Association (NFPA) defines four classes of fire. Each of these classes involves a different mode of combustion.

Class A (Wood, Trash, Paper)

Class A fires contain ordinary combustible materials, such as paper, cloth, wood, and plastics. These type fuels require the heat-absorbing effects of water (cooling) or water solutions. Class A fires consist of two types: Flaming combustion which involves gases which result from the thermal decomposition of the fuel. The second type is deep-seated or glowing. This type represents combustion within the mass of the fuel and has a slow rate of heat loss and a slow rate of reaction between oxygen and fuel.

A TRASH • WOOD • PAPER



Class B

Class B fires consist of flammable or combustible gases, and liquids. Extinguishment is normally accomplished by excluding (eliminating) oxygen, interrupting the combustion of the chain reaction, or stopping the release of the combustible vapors.

B LIQUIDS • GREASE



The type of Class B hazards are either water soluble (meaning they mix with water) or water insoluble (meaning they will not mix with water). For water soluble fuels, special alcohol-resistant foam agents that will not mix with the fuel are required.

Class C

Class C fires involve energized electrical equipment. In these type fires, operator safety requires that the extinguishing agents are electrically non-conductive. Foam agents are not recommended for energized Class C fires. High water content in the agent causes the agent to be conductive. However, if the electrical equipment is shut off (de-energized), foam agents can be used.

C ELECTRICAL EQUIP



SECTION 3 – INTRODUCTION

Class D

Class D fires involve combustible metals such as titanium, potassium, magnesium, sodium, etc. These types of metals require a heat-absorbing extinguishing agent that doesn't react to the burning metal. Metals burn at higher temperatures but the flames are not as intense. In some cases, metal fires can become deep-seated or explosive. The nature of the combustion process will depend on the properties of the metal involved.



Foam agents are not recommended for Class D fires because of the reaction of some of the burning metals with water.

Class K

Fires that involve cooking oils or fats. Though such fires are technically a subclass of the flammable liquid/gas class, the special characteristics of these fires are considered important enough to recognize separately.



Classes Of Fire (European)

In Europe, fires can be divided into six classes:

- **Class A:** These are fires involving flammable solids, e.g. wood, cloth, rubber, paper, and some types of plastics.
- **Class B:** These are fires involving flammable liquids or liquefiable solids, e. g. petrol, oil, paint, and also some waxes and plastics, but not cooking fats and oil.
- **Class C:** These are fires involving flammable gases, e.g. natural gas, hydrogen, propane, butane.
- **Class D:** These are fires involving combustible metals, e.g. sodium, magnesium, and potassium.
- **Class E:** Involving electrical appliances. (*No longer used*). When power to appliances is turned off, an electrical fire can fall into any of the other categories.
- **Class F:** These are fires involving cooking fats and oils. The high temperature of these types of fats and oils when on fire far exceed that of other flammable liquids which means that normal fire extinguishers should not be used.



Foam agents are not recommended for Class D fires because of the reaction of some of the burning metals with water.

How Foam Is Made

Finished foam is a combination of a foam concentrate, water, and air. When these three components are brought together in the proper proportions and mixed, foam is produced. The following Figure 6 shows how the final foam is made through a typical proportioning device.

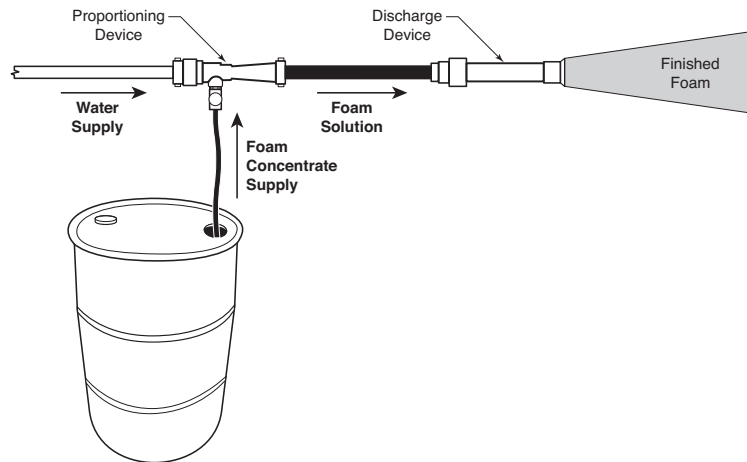

Foam Characteristics

To be effective, good foam must contain the correct blend of physical characteristics:

- **Knockdown Speed and Flow** – This refers to the time required for the foam blanket to spread across a fuel surface or around obstacles in order to achieve complete extinguishment.
- **Heat Resistance** – Foam must be able to resist the effects of heat from any remaining fire from the liquid’s flammable vapor or heated objects.
- **Fuel Resistance** – Effective foam minimizes fuel pick-up so that the foam does not become saturated and burn.
- **Vapor suppression** – A vapor-tight blanket must be capable of suppressing the flammable vapors and minimize the rise of reigniting.
- **Alcohol Resistance** – Foam blankets are more than 90% water. Because of this, foam blankets that are not alcohol-resistant will last very long.

Foam Testing

SECTION 3 – INTRODUCTION

Third party approval agencies, (such as UL, ULC, USCG, DIN, EN), require different approval testing for foam concentrates. Along with the individual agency testing, testing of concentrates include density, pH, and viscosity. Foam quality is a measure of the physical properties of foam. These are stated as the expansion ratio and 25% drain time.

Expansion Ratio

Expansion ratio is the comparison between the final foam volume to the original foam solution before air is added to the solution.

NFPA classifies the foam concentrates by listing the expansion ratio as follows;

- **Low Expansion** – Expansion ratio up to 20:1
- **Medium Expansion** – Expansion ratio from 20:1 to 200:1
- **High Expansion** – Expansion ratio above 200:1

Quarter Drain Time

Quarter drain time is the measure of time required to drain the volume of the liquid having a weight of 25% of the total foam sample.

Burn back Resistance

Another required test is called burn back resistance. Burn back resistance is defined as the ability of the foam blanket to resist the radiant heat after the fire is extinguished, and to prevent the reigniting of the fuel. This test varies based on type of concentrate and the approval agency required.

Compatibility

Compatibility between different foam agents from different foam manufacturers is very important. A situation could happen where different manufacturers foam concentrates are mixed together in the same storage vessel, such as a bladder tank. Concentrates are determined to be compatible when the physical and chemical characteristics of the mixed concentrates perform at least equal to that of each individual concentrate in the mixture.

NFPA 11, Standard for Low, Medium, and High Expansion Foam states that “different types and brands of concentrates may be incompatible and shall not be mixed in storage”

Although compatibility is a concern in storage, NFPA 11 states that “foams generated separately from protein, fluoroprotein and AFFF concentrates may be applied to a fire in sequence or simultaneously”.

Foam Handling

SOLBERG foam concentrates will provide years of service if they are properly stored and handled.

All Solberg’s foam concentrates have a shelf life based on number of years. The shelf life is valid only when the concentrates are stored in their original container and in accordance with the manufacturer’s requirements stated on the data sheets for each individual concentrate. See Section 4 – Foam Agent Data Sheets, for detailed storage and handling information.

Types Of Foam

There are several types of available foams. Each foam concentrate is developed for a specific application. Some foams

are thick and form a heavy, heat-resistant covering over a burning liquid surface. Other types of foams are thinner and because of that, they will spread much more quickly over the fuel surface. Other types of foams will generate a vapor sealing film on the surface of the fuel. Additional foam concentrate types, such as medium and high expansion foams, can be used in applications requiring large volumes to flood surfaces and fill cavities within the hazard.

Synthetic Foams

This type of foam concentrate is based on a mixture of surfactants and solvents, both fluorinated and fluoropolymer-free. These types of foam concentrates may or may not form films or membranes on the fuel surface, depending on the foam concentrate and the fuel being protected. The following Solberg foam concentrates are within this category:

- RE-HEALING RF Fluoro-free Foam Concentrates
- ARCTIC AFFF Foam Concentrates
- ARCTIC ATC Foam Concentrates
- FIRE-BRAKE Foam Concentrate

Protein Foams

Protein foams are manufactured with naturally-occurring sources of protein, such as hoof and horn meal or feather meal. They are intended for use on hydrocarbon fuels only. Foams made from protein foam concentrates usually have a good heat stability and resist burnback. They must be properly aspirated and should not be used with non-aspirating fog nozzles. These foams are generally not as mobile or fluid on the fuel surface as other types of low expansion foams. Protein foams are susceptible to fuel pickup, therefore, care should be taken to minimize the foam and fuel from submerging.

Fluoroprotein Foams

Fluoroprotein foams are a derivative of protein foams. Fluoroprotein foams have fluorochemical surfactants added. They are intended for use on hydrocarbon fuels and selected oxygenated fuel additives. They must be properly aspirated and should not be used with non-aspirating fog nozzles.

Chemical Foams

These foams are produced by the chemical reaction which occurs when the two chemicals, aluminum sulfate and sodium bicarbonate and mixed together. The energy required to create the foam bubbles comes from this reaction between the two chemicals. This type of foam is obsolete.

For existing systems containing chemical foams, contact Solberg Technical Services for recommendations on upgrading this technology to a commercial viable system.

Class-A Foams

Class A foam is a synthetic fire fighting foam concentrate specially designed to be used for wild fires and other Class A fires. It has the ability to reduce the surface tension of water which substantially increases the overall wetting capability. This creates a faster penetration and greater control when attacking combustible solids such as wood, paper, and trees. The following Solberg foam concentrate is within this category:

- FIRE-BRAKE Class A foam concentrate

Evolution Of Class B Firefighting Foams

SECTION 3 – INTRODUCTION

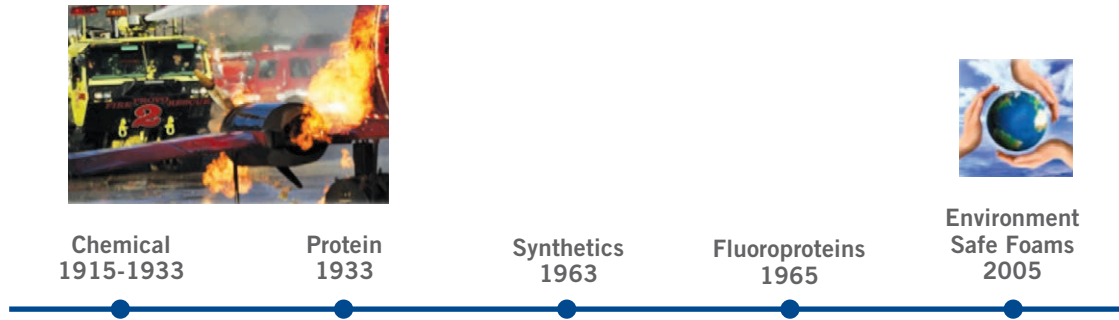

Firefighting foams have been on the market for almost 100 years in various types. Firefighting foams started with chemical foams, at each of these steps along the way, performance and safety of these various agents improved on the prior foam agent types/concentration.

Early 1900s – The 1st foams were chemical foams. They functioned by a chemical reaction from mixing two or more chemicals at the time of use, which created the foaming. More effective than water, but difficult to use and transport. Also, there was always the risk of improper mixing at the time of use.

1930s – Protein foams were a major improvement. They were chemically stable and effective on Class B fires. At that time, they quickly became the industry standard. Their major drawback was limited shelf life and limited storage temperatures, issues that are still problems for protein based products today.

Also, protein foams work best when they are discharged through air aspirating equipment which creates a thick foam blanket, but depending on the type of foam discharge equipment, can negatively affect the discharge range compared to non-aspirated equipment.

1960s - Synthetics (AFFF and AR-AFFF) entered the market. They have the ability to readily spread over a fuel surface, are very forgiving during a fire, they can be discharged through all types of nozzles, and have an extended shelf life. Fluorinated synthetic foams are the mainstay of the foam fire protection industry, and have only recently been under review, not for their firefighting performance, but due to their environmental impact. Current synthetics are capable of extinguishing hydrocarbon and water soluble fuels, and can be discharged through air aspirating and non-aspirating nozzles, allowing maximum flexibility during use.

Mid-1960s - Fluoroprotein foam was introduced after the synthetics, mainly as a market response by the protein foam manufacturers. Adding fluorosurfactant to standard protein foams allowed the protein foams to more readily spread on the fuel surface. This step improved the performance of the protein based foams to somewhere between protein only foam and the fluorinated synthetics.

Present - Environment Friendly Foams – As environmental regulations on fluorinated synthetic foam concentrates increase around the world, a new generation of environment friendly foam concentrates has been developed. Solberg's RE-HEALING foam concentrate is an innovative environmentally sustainable fluorosurfactant and fluoropolymer-free firefighting foam used to effectively extinguish Class B fuels with no environmental or toxic breakdown. Solberg RE-HEALING foam concentrate is formulated using a new high performance synthetic foam technology designed to replace traditional AFFF and AR-AFFF foam concentrates and older fluoroprotein foams.

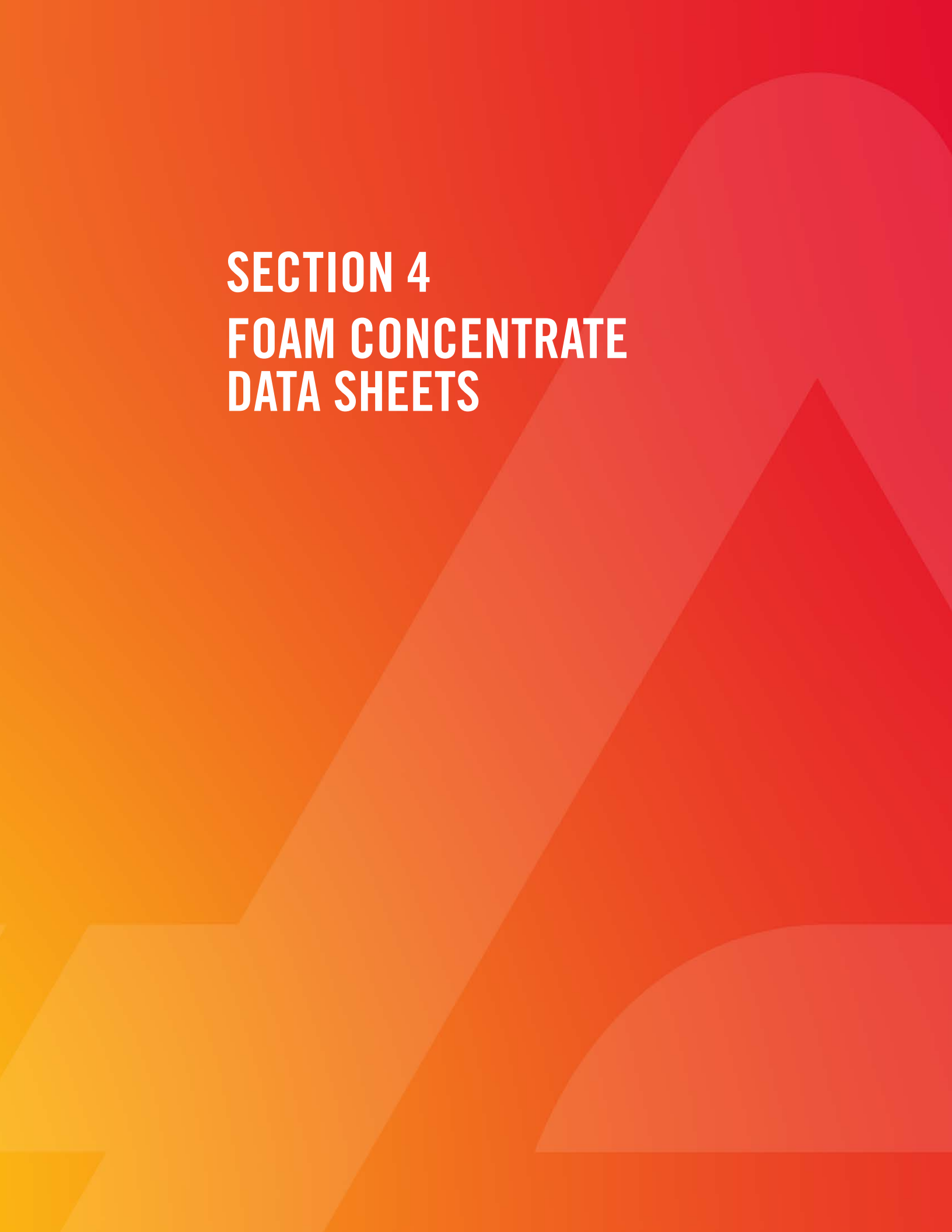
The background features a gradient from yellow-orange on the left to red on the right. Large, semi-transparent geometric shapes, including a large triangle and a rounded rectangle, are layered across the background in shades of red and orange.

SECTION 4

FOAM CONCENTRATE

DATA SHEETS

Foam Concentrates

Solberg offers an extensive line of firefighting foam concentrates for the control and extinguishment of Class A and Class B fires. The range includes:

Environmentally Sustainable

RE-HEALING™ Foam

Authentic 100% fluorosurfactant, fluoropolymer-free foam concentrates for Class B fires.

ARCTIC™ Foam

Aqueous Film Forming Foam (AFFF) and Aqueous Film Forming Foam – Alcohol Type Concentrate (ATC) foam concentrates for Class B fires.

FIRE-BRAKE™ Foam

Environmentally sustainable wild land urban interface foam concentrate for Class A fires.

Solberg has developed some of the most advanced firefighting foam concentrates and custom-designed foam suppression systems and hardware on the market. With industry-leading experts, worldwide experience and global reach, we continually pioneer firefighting foam concentrate technologies to meet the latest demands in the industry.

MARKETS

Aerospace
 Aviation
 Chemical
 Defense
 Energy
 Fire Service
 Marine
 Mining
 Oil & Gas
 Petrochemical
 Pharmaceuticals
 Pipelines
 Solvents & Coatings
 Utilities

APPLICATIONS

Aircraft Hangars
 Crash Rescue Vehicles
 Dike Areas
 Docks
 Heliports & Helidecks
 Jetties
 Loading Racks
 Manufacturing Processes
 Pumping Stations
 Power Plants
 Storage Tanks
 Warehouses

SECTION 4.1

FOAM CONCENTRATE DATA SHEETS

RE-HEALING™ Foam Concentrates

SOLBERG® RE-HEALING™ RFI-AG, 1% FOAM CONCENTRATE



TYPICAL PHYSICAL PROPERTIES

AT 77 °F (25 °C)

Appearance: Clear, yellow-orange liquid

Freezing Point: -11°F (-24°C)
(No quality loss after thawing)

Maximum Storage Temp: 122°F (50°C)

pH: 7.0 - 8.5

Refractive Index: 1.4580 - 1.4680

Specific Gravity: 1.120 - 1.130

Viscosity: < 20 cSt*

Sediments: < 0.05%

*Cannon-Fenske Viscometer



APPLICATIONS

SOLBERG RE-HEALING RFI-AG foam concentrate is intended for use on Class B hydrocarbon fuel fires. It is not intended for use on Class B polar solvent fuels. The foam can be used to prevent re-ignition of a liquid spill and control hazardous vapors. On Class A fuels, SOLBERG RE-HEALING RFI-AG foam will improve extinguishment in deep-seated fires. Foam discharge devices such as air aspirating, as well as non-air aspirating equipment can be used to obtain maximum results. The product is mixed 1 part foam concentrate to 99 parts water. It may also be used as a 1% pre-mix solution. SOLBERG RE-HEALING RFI-AG foam is compatible with most dry powder (chemical) agents.

PERFORMANCE

Fire Performance

SOLBERG RE-HEALING RFI-AG foam concentrate has been tested to and meets the fire performance test criteria of European Standard EN 1568 Part 3 (latest edition).

Foam Proportioning

SOLBERG RE-HEALING RFI-AG foam concentrate can be proportioned at the proper foam solution percentage using common foam proportioning devices such as:

- Eductors
- Inline balanced pressure proportioners
- Ratio controllers
- Self-educing nozzles

DESCRIPTION

SOLBERG® RE-HEALING™ RFI-AG, 1% foam concentrate from SOLBERG is an innovative environmentally sustainable fluorosurfactant and fluoropolymer-free foam concentrate used to effectively extinguish Class B hydrocarbon fuel fires. Proportioned at 1% solution, SOLBERG RE-HEALING RFI-AG foam concentrate can be used in fresh and salt water. SOLBERG RE-HEALING RFI-AG foam concentrate possesses excellent burn back resistance due to its remarkable flow and rapid resealing characteristics. SOLBERG RE-HEALING RFI-AG foam concentrate is formulated using a new high performance synthetic foam technology to replace traditional AFFF, FFFP foam concentrates and older protein and fluoroprotein foams.

STORAGE

The storage temperature range for SOLBERG RE-HEALING RFI-AG foam concentrate is -11°F to 122°F (-24°C to 50°C).

When stored in original containers or in manufacturer recommended equipment and within the specified temperature range, the shelf life is 20 years.

COMPATIBILITY

SOLBERG RE-HEALING RFI-AG foam concentrate should not be mixed with other foam concentrates. For questions about compatibility or mixing, consult Perimeter Solutions Technical Services.

Materials of Construction Capability

SOLBERG RE-HEALING RFI-AG foam concentrate is compatible with multiple materials of construction such as carbon steel, stainless steel, brass, polyethylene and PVC. Galvanized steel should not be used in direct contact with the foam concentrate. For questions about materials of construction compatibility, consult Perimeter Solutions Technical Services.

INSPECTION

SOLBERG RE-HEALING RFI-AG foam concentrate or pre-mix solution should be inspected annually per National Fire Protection Association (NFPA) Standards 11 and 25. A sample of the foam concentrate should be sent to the manufacturer for quality conditioning testing in accordance to NFPA 11.

SOLBERG® RE-HEALING™ RF1-AG, 1% FOAM CONCENTRATE

ENVIRONMENT INFORMATION

SOLBERG RE-HEALING foam concentrates do not contain intentionally added PFAS chemicals including PFOA and PFOS. In making this statement, SOLBERG relies on information provided by its raw material suppliers and certain independent laboratory analysis conducted on the product.

CERTIFICATION

SOLBERG manufactured products are thoroughly inspected and undergo rigorous quality control tests. These evaluations analyze the foam's physical parameters as well as the finished product's fire performance. A Certificate of Analysis (CoA) is issued with every batch. SOLBERG RE-HEALING RF1-AG foam concentrate is European Standard EN 1568 Part 3 Approved.

ORDERING INFORMATION

SOLBERG RE-HEALING RF1-AG foam concentrate is available in pails, drums, totes and bulk quantities.

Part No.	Description	Approximate Shipping Weight	Approximate Cube
20840	SOLBERG RE-HEALING RF1-AG, 1% - 5 gallon (20 litre) pail	45 lb (21 kg)	1.25 ft ³ (0.04 m ³)
20841	SOLBERG RE-HEALING RF1-AG, 1% - 55 gallon (200 litre) drum	495 lb (224 kg)	11.83 ft ³ (0.33 m ³)
20842	SOLBERG RE-HEALING RF1-AG, 1% - 265 gallon (1000 litre) tote	2465 lb (1118 kg)	50.05 ft ³ (1.42 m ³)
20843	SOLBERG RE-HEALING RF1-AG, 1% - bulk	Call Customer Services	



Solutions That Save.

FOR MORE INFORMATION

Contact any of our worldwide Perimeter Solutions Fire Safety offices or visit:

www.Perimeter-Solutions.com

UNITED STATES

10667 Jersey Blvd.
Rancho Cucamonga, CA 91730
Tel: +1 800 682 3626
Tel: +1 909 983 0772
salesfoamusa@perimeter-solutions.com

EMEA

Polígono de Baiña, Parcela 23
33682 Mieres (Asturias)
Spain
Tel: +34 985 24 29 45
salesfoamemea@perimeter-solutions.com

ASIA PACIFIC

3 Charles Street
St Marys NSW 2760 – Australia
Tel: +61 2 9673 5300
salesfoamapac@perimeter-solutions.com

perimeter-solutions.com

NOTICE PERIMETER SOLUTIONS MAKES NO REPRESENTATIONS OR WARRANTIES AS TO THE COMPLETENESS OR ACCURACY OF THE INFORMATION INCLUDED HEREIN. THE INFORMATION CONTAINED HEREIN IS NOT INTENDED TO PROVIDE REGULATORY, LEGAL OR EXPERT ADVICE RELATING TO THE PRODUCTS, ITS APPLICATION OR USES. NOTHING CONTAINED HEREIN IS TO BE CONSTRUED AS A RECOMMENDATION TO USE ANY PRODUCT, PROCESS, EQUIPMENT OR FORMULATION IN CONFLICT WITH ANY INDUSTRIAL PROPERTY OR INTELLECTUAL PROPERTY RIGHTS, AND PERIMETER SOLUTIONS MAKES NO REPRESENTATION OR WARRANTY, EXPRESS OR IMPLIED, THAT THE USE THEREOF WILL NOT INFRINGE ON ANY INDUSTRIAL PROPERTY OR INTELLECTUAL PROPERTY RIGHTS. NO REPRESENTATIONS OR WARRANTIES, EITHER EXPRESSED OR IMPLIED, OF MERCHANTABILITY, FITNESS FOR A PARTICULAR PURPOSE OR OF ANY OTHER NATURE ARE MADE HEREUNDER WITH RESPECT TO THE INFORMATION CONTAINED HEREIN.

SOLBERG® RE-HEALING™ RF3, 3% FOAM CONCENTRATE



TYPICAL PHYSICAL PROPERTIES AT 77 °F (25 °C)

Appearance: Brown liquid
Freezing Point: 23 °F (-5 °C)
 (No quality loss after thawing)
Maximum Storage Temp: 120°F (49°C)
pH: 7.0 - 8.0
Refractive Index: 1.3865 - 1.3869
Specific Gravity: 1.06 - 1.10
Viscosity: 4900 - 5300 cP*
Sediments: < 0.05%
 *Brookfield Viscometer Spindle #4, Speed 30 rpm

APPLICATIONS

SOLBERG RE-HEALING RF3 foam concentrate is intended for use on Class B hydrocarbon fuel fires. It is not intended for use on Class B polar solvent fuels. The foam can be used to prevent re-ignition of a liquid spill and control hazardous vapors. On Class A fuels, SOLBERG RE-HEALING RF3 foam will improve extinguishment in deep-seated fires. Foam discharge devices such as air aspirating, as well as, non-air aspirating equipment, including standard fire sprinkler heads, can be used to obtain maximum results. The product is mixed 3 part foam concentrate to 97 parts water. It may also be used as a 3% pre-mix solution. SOLBERG RE-HEALING RF3 foam is compatible with most dry powder (chemical) agents.†

PERFORMANCE

Fire Performance

SOLBERG RE-HEALING RF3 foam concentrate has been tested to and meets the fire performance test criteria of Underwriters Laboratories, Inc. (UL) Standard 162, Underwriters' Laboratories of Canada (ULC) Standard S564, FM Approval Standard 5130, European Standard EN 1568 Part 3 and International Civil Aviation Organization (ICAO) Levels B and C.

Foam Proportioning

SOLBERG RE-HEALING RF3 foam concentrate can be proportioned at the proper foam solution percentage using common foam proportioning devices†† such as:

- Eductors
- Inline balanced pressure proportioners
- Ratio controllers
- Self-educting nozzles



DESCRIPTION

SOLBERG® RE-HEALING™ RF3 foam concentrate from SOLBERG is an innovative environmentally sustainable fluorosurfactant and fluoropolymer-free foam concentrate used to effectively extinguish Class B hydrocarbon fuel fires. Proportioned at 3% solution, SOLBERG RE-HEALING RF3 foam concentrate can be used in fresh, salt or brackish water. SOLBERG RE-HEALING RF3 foam possesses excellent burn back resistance due to its remarkable flow and rapid resealing characteristics. SOLBERG RE-HEALING foam concentrates are formulated using a new high performance synthetic foam technology to replace traditional AFFF, FFFP foam concentrates and older protein and fluoroprotein foams. RE-HEALING RF3 foam concentrate contains no sediments.

STORAGE

The storage temperature range for SOLBERG RE-HEALING RF3 foam concentrate is 35°F to 120°F (1.7°C to 49°C).

When stored in original containers or in manufacturer recommended equipment and within the specified temperature range, the shelf life is 20 years.

COMPATIBILITY

SOLBERG RE-HEALING RF3 foam concentrate should not be mixed with other foam concentrates. For questions about compatibility or mixing, consult Perimeter Solutions Technical Services.

Materials of Construction Capability

SOLBERG RE-HEALING RF3 foam concentrate is compatible with multiple materials of construction such as carbon steel, stainless steel, brass, polyethylene and PVC. Galvanized steel should not be used in direct contact with the foam concentrate. For questions about materials of construction compatibility, consult Perimeter Solutions Technical Services.

INSPECTION

SOLBERG RE-HEALING RF3 foam concentrate or pre-mix solution should be inspected annually per National Fire Protection Association (NFPA) Standards 11 and 25. A sample of the foam concentrate should be sent to the manufacturer for quality conditioning testing in accordance to NFPA 11.

ENVIRONMENT INFORMATION

SOLBERG RE-HEALING foam concentrates do not contain intentionally added PFAS chemicals including PFOA and PFOS. In making this statement, SOLBERG relies on information provided by its raw material suppliers and certain independent laboratory analysis conducted on the product.

SOLBERG® RE-HEALING™ RF3, 3% FOAM CONCENTRATE

CERTIFICATION

SOLBERG manufactured products are thoroughly inspected and undergo rigorous quality control tests. These evaluations analyze the foam's physical parameters as well as the finished product's fire performance. A Certificate of Analysis (CoA) is issued with every batch.

SOLBERG RE-HEALING RF3 foam concentrate is:

- Underwriters Laboratories, Inc. Listed in accordance with UL 162 (Standard for Safety for Foam Equipment and Liquid Concentrates)
- Underwriters' Laboratories of Canada Listed (Standard for Category 1 Foam Liquid Concentrates ULC S564)
- FM Approved per Approval Standard 5130
- European Norm (EN) Standard 1568 Part 3 Approved
- International Civil Aviation Organization (ICAO) Airport Services Manual (DOC 9137-AN/898) Part 1 - Rescue and Firefighting, Levels B and C Certified

ORDERING INFORMATION

SOLBERG RE-HEALING RF3 foam concentrate is available in pails, drums, totes and bulk quantities.

Part No.	Description	Approximate Shipping Weight	Approximate Cube
20020	SOLBERG RE-HEALING RF3, 3%, 5 gallon (20 litre) pail	45 lb (21 kg)	1.25 ft ³ (0.04 m ³)
20021	SOLBERG RE-HEALING RF3, 3%, 55 gallon (200 litre) drum	495 lb (224 kg)	11.83 ft ³ (0.33 m ³)
20022	SOLBERG RE-HEALING RF3, 3%, 265 gallon (1000 litre) tote	2465 lb (1118 kg)	50.05 ft ³ (1.42 m ³)
20023	SOLBERG RE-HEALING RF3, 3%, bulk	Call Customer Services	

† Not an FM Approved Configuration

†† See FM Approval Guide



Solutions That Save.

FOR MORE INFORMATION

Contact any of our worldwide Perimeter Solutions Fire Safety offices or visit:

www.Perimeter-Solutions.com

UNITED STATES

10667 Jersey Blvd.
Rancho Cucamonga, CA 91730

Tel: +1 800 682 3626
Tel: +1 909 983 0772

salesfoamusa@perimeter-solutions.com

EMEA

Polígono de Baiña, Parcela 23
33682 Mieres (Asturias)

Spain
Tel: +34 985 24 29 45

salesfoamea@perimeter-solutions.com

ASIA PACIFIC

3 Charles Street
St Marys NSW 2760 – Australia

Tel: +61 2 9673 5300

salesfoamapac@perimeter-solutions.com

perimeter-solutions.com

NOTICE PERIMETER SOLUTIONS MAKES NO REPRESENTATIONS OR WARRANTIES AS TO THE COMPLETENESS OR ACCURACY OF THE INFORMATION INCLUDED HEREIN. THE INFORMATION CONTAINED HEREIN IS NOT INTENDED TO PROVIDE REGULATORY, LEGAL OR EXPERT ADVICE RELATING TO THE PRODUCTS, ITS APPLICATION OR USES. NOTHING CONTAINED HEREIN IS TO BE CONSTRUED AS A RECOMMENDATION TO USE ANY PRODUCT, PROCESS, EQUIPMENT OR FORMULATION IN CONFLICT WITH ANY INDUSTRIAL PROPERTY OR INTELLECTUAL PROPERTY RIGHTS, AND PERIMETER SOLUTIONS MAKES NO REPRESENTATION OR WARRANTY, EXPRESS OR IMPLIED, THAT THE USE THEREOF WILL NOT INFRINGE ON ANY INDUSTRIAL PROPERTY OR INTELLECTUAL PROPERTY RIGHTS. NO REPRESENTATIONS OR WARRANTIES, EITHER EXPRESSED OR IMPLIED, OF MERCHANTABILITY, FITNESS FOR A PARTICULAR PURPOSE OR OF ANY OTHER NATURE ARE MADE HEREUNDER WITH RESPECT TO THE INFORMATION CONTAINED HEREIN.

SOLBERG® RE-HEALING™ RF6, 6% FOAM CONCENTRATE



TYPICAL PHYSICAL PROPERTIES

AT 77 °F (25 °C)

Appearance: Brown liquid

Freezing Point: 23°F (-5°C)

(No quality loss after thawing)

Maximum Storage Temp: 120°F (49°C)

pH: 7.0 - 8.5

Refractive Index: 1.3650 - 1.3750

Specific Gravity: 1.055 - 1.070

Viscosity: 4500 - 5500 cP*

Sediments: None

*Brookfield Viscometer Spindle #4,

Speed 30 rpm

APPLICATIONS

SOLBERG RE-HEALING RF6 foam concentrate is intended for use on Class B hydrocarbon fuel fires. It is not intended for use on Class B polar solvent fuels. The foam can be used to prevent re-ignition of a liquid spill and control hazardous vapors. On Class A fuels, SOLBERG RE-HEALING RF6 foam will improve extinguishment in deep-seated fires. Foam discharge devices such as air aspirating, as well as, non-air aspirating equipment, including standard sprinkler heads, can be used to obtain maximum results. The product is mixed 6 part foam concentrate to 94 parts water. It may also be used as a 6% pre-mix solution. SOLBERG RE-HEALING RF6 foam is compatible with most dry powder (chemical) agents.

PERFORMANCE

Fire Performance

SOLBERG RE-HEALING RF6 foam concentrate has been tested to and meets the fire performance test criteria of European Standard EN 1568 Part 3 and International Civil Aviation Organization (ICAO) Level B.

Foam Proportioning

SOLBERG RE-HEALING RF6 foam concentrate can be proportioned at the proper foam solution percentage using common foam proportioning devices such as:

- Eductors
- Inline balanced pressure proportioners
- Ratio controllers
- Self-educing nozzles



DESCRIPTION

RE-HEALING™ RF6 foam concentrate from SOLBERG® is an innovative environmentally sustainable fluorosurfactant and fluoropolymer-free foam concentrate used to effectively extinguish Class B hydrocarbon fuel fires. Proportioned

at 6% solution, SOLBERG RE-HEALING RF6 foam concentrate can be used in fresh, salt or brackish water. SOLBERG RE-HEALING RF6 foam possesses excellent burn back resistance due to its remarkable flow and rapid resealing characteristics. RE-HEALING foam concentrates are formulated using a new high performance synthetic foam technology to replace traditional AFFF, FFFP foam concentrates and older protein and fluoroprotein foams.

STORAGE

The storage temperature range for SOLBERG RE-HEALING RF6 foam concentrate is 35°F to 120°F (1.7°C to 49°C).

When stored in original containers or in manufacturer recommended equipment and within the specified temperature range, the shelf life is 20 years.

COMPATIBILITY

SOLBERG RE-HEALING RF6 foam concentrate should not be mixed with other foam concentrates. For questions about compatibility or mixing, consult Solberg Technical Services.

Materials of Construction Capability

SOLBERG RE-HEALING RF6 foam concentrate is compatible with multiple materials of construction such as carbon steel, stainless steel, brass, polyethylene and PVC. Galvanized steel should not be used in direct contact with the foam concentrate. For questions about materials of construction compatibility, consult Solberg Technical Services.

SOLBERG® RE-HEALING™ RF6, 6% FOAM CONCENTRATE

INSPECTION

SOLBERG RE-HEALING RF6 foam concentrate or pre-mix solution should be inspected annually per National Fire Protection Association (NFPA) Standards 11 and 25. A sample of the foam concentrate should be sent to the manufacturer for quality conditioning testing in accordance to NFPA 11.

ENVIRONMENTAL INFORMATION

SOLBERG RE-HEALING foam concentrates are fluorosurfactant, fluoropolymer-free products for use on Class B hydrocarbon fuels with no environmental concerns for persistence, bioaccumulation or toxic break down.

CERTIFICATIONS

SOLBERG manufactured products are thoroughly inspected and undergo rigorous quality control tests. These evaluations analyze the foam's physical parameters as well as the finished product's fire performance. A Certificate of Analysis (CoA) is issued with every batch.

SOLBERG RE-HEALING RF6 foam concentrate is Approved to European Standard EN 1568 Part 3 and International Civil Aviation Organization (ICAO) Level B.

ORDERING INFORMATION

SOLBERG RE-HEALING RF6 foam concentrate is available in pails, drums, totes and bulk quantities.

Part No.	Description	Approximate Shipping Weight	Approximate Cube
20040	SOLBERG RE-HEALING RF6, 6% Foam, 20 litre (5 gallon) pail	21 kg (45 lb)	0.04 m ³ (1.25 ft ³)
20041	SOLBERG RE-HEALING RF6, 6% Foam, 200 litre (55 gallon) drum	224 kg (495 lb)	0.33 m ³ (11.83 ft ³)
20042	SOLBERG RE-HEALING RF6, 6% Foam, 1000 litre (265 gallon) tote	1118 kg (2465 lb)	1.42 m ³ (50.05 ft ³)
20043	SOLBERG RE-HEALING RF6, 6% Foam, bulk	Call Customer Services	



Solutions That Save.

FOR MORE INFORMATION

Contact any of our worldwide Perimeter Solutions Fire Safety offices or visit:

www.Perimeter-Solutions.com

UNITED STATES

10667 Jersey Blvd.
Rancho Cucamonga, CA 91730

Tel: +1 800 682 3626
Tel: +1 909 983 0772

salesfoamusa@perimeter-solutions.com

EMEA

Polígono de Baiña, Parcela 23
33682 Mieres (Asturias)
Spain

Tel: +34 985 24 29 45

salesfoamemea@perimeter-solutions.com

ASIA PACIFIC

3 Charles Street
St Marys NSW 2760 – Australia

Tel: +61 2 9673 5300

salesfoamapac@perimeter-solutions.com

perimeter-solutions.com

NOTICE PERIMETER SOLUTIONS MAKES NO REPRESENTATIONS OR WARRANTIES AS TO THE COMPLETENESS OR ACCURACY OF THE INFORMATION INCLUDED HEREIN. THE INFORMATION CONTAINED HEREIN IS NOT INTENDED TO PROVIDE REGULATORY, LEGAL OR EXPERT ADVICE RELATING TO THE PRODUCTS, ITS APPLICATION OR USES. NOTHING CONTAINED HEREIN IS TO BE CONSTRUED AS A RECOMMENDATION TO USE ANY PRODUCT, PROCESS, EQUIPMENT OR FORMULATION IN CONFLICT WITH ANY INDUSTRIAL PROPERTY OR INTELLECTUAL PROPERTY RIGHTS, AND PERIMETER SOLUTIONS MAKES NO REPRESENTATION OR WARRANTY, EXPRESS OR IMPLIED, THAT THE USE THEREOF WILL NOT INFRINGE ON ANY INDUSTRIAL PROPERTY OR INTELLECTUAL PROPERTY RIGHTS. NO REPRESENTATIONS OR WARRANTIES, EITHER EXPRESSED OR IMPLIED, OF MERCHANTABILITY, FITNESS FOR A PARTICULAR PURPOSE OR OF ANY OTHER NATURE ARE MADE HEREUNDER WITH RESPECT TO THE INFORMATION CONTAINED HEREIN.

SOLBERG® RE-HEALING™ RF3X6% ATC™ FOAM CONCENTRATE



TYPICAL PHYSICAL PROPERTIES

AT 77 °F (25 °C)

Appearance: Brown liquid

Freezing Point: -23°F (-5°C)

(No quality loss after thawing)

Maximum Storage Temp: 122°F (50°C)

pH: 7.0 - 8.5

Refractive Index: 1.3750 - 1.3850

Specific Gravity: 1.050 - 1.085

Viscosity: 4300 - 5900 cP*

Sediments: < 0.05%

*Brookfield Viscometer Spindle #4,
Speed 30 rpm



APPLICATIONS

SOLBERG RE-HEALING RF3x6 ATC foam concentrate is intended for use on Class B hydrocarbon or polar solvent fuel fires. The foam can be used to prevent re-ignition of a liquid spill and control hazardous vapors. On Class A fuels, SOLBERG RE-HEALING RF3x6 ATC foam will improve extinguishment in deep-seated fires. Foam discharge devices such as air aspirating, as well as non-air aspirating equipment, including standard sprinkler heads, can be used to obtain maximum results. The product is mixed 3 parts foam concentrate to 97 parts water for hydrocarbon fuels or 6 parts foam concentrate to 94 parts water for polar solvent fuels. It may also be used as a pre-mix solution. SOLBERG RE-HEALING RF3x6 ATC foam is compatible with most dry powder (chemical) agents.

PERFORMANCE

Fire Performance

SOLBERG RE-HEALING RF3x6 ATC foam concentrate has been tested to and meets the fire performance test criteria of European Standard EN 1568 Part 3 & 4 and International Civil Aviation Organization (ICAO) Levels B and C.

Foam Proportioning

SOLBERG RE-HEALING RF3x6 ATC foam concentrate can be proportioned at the proper foam solution percentage using common foam proportioning devices such as:

- Eductors
- Inline balanced pressure proportioners
- Ratio controllers
- Self-educting nozzles

DESCRIPTION

SOLBERG® RE-HEALING™ RF3x6 ATC foam concentrate from SOLBERG is an innovative environmentally sustainable fluorosurfactant and fluoropolymer-free foam concentrate used to effectively extinguish Class B hydrocarbon fuel fires at 3% and polar solvent fuel fires at 6% solution. SOLBERG RE-HEALING RF3x6 ATC foam can be used in fresh, salt or brackish water. SOLBERG RE-HEALING RF3x6 ATC foam possesses excellent burn back resistance due to its remarkable flow and rapid resealing characteristics. SOLBERG RE-HEALING foam concentrates are formulated using a new high performance synthetic foam technology to replace traditional AFFF, FFFP foam concentrates and older protein and fluoroprotein foams.

STORAGE

The storage temperature range for SOLBERG RE-HEALING RF3x6 ATC foam concentrate is 35°F to 120°F (1.7°C to 49°C).

When stored in original containers or in manufacturer recommended equipment and within the specified temperature range, the shelf life is 20 years.

COMPATIBILITY

SOLBERG RE-HEALING RF3x6 ATC foam concentrate should not be mixed with other foam concentrates. For questions about compatibility or mixing, consult Perimeter Solutions Technical Services.

Materials of Construction Capability

SOLBERG RE-HEALING RF3x6 ATC foam concentrate is compatible with multiple materials of construction such as carbon steel, stainless steel, brass, polyethylene and PVC. Galvanized steel should not be used in direct contact with the foam concentrate. For questions about materials of construction compatibility, consult Perimeter Solutions Technical Services.

INSPECTION

SOLBERG RE-HEALING RF3x6 ATC foam concentrate or pre-mix solution should be inspected annually per National Fire Protection Association (NFPA) Standards 11 and 25. A sample of the foam concentrate should be sent to the manufacturer for quality conditioning testing in accordance to NFPA 11.

SOLBERG® RE-HEALING™ RF3X6% ATC™ FOAM CONCENTRATE

ENVIRONMENTAL INFORMATION

SOLBERG RE-HEALING foam concentrates do not contain intentionally added PFAS chemicals including PFOA and PFOS. In making this statement, SOLBERG relies on information provided by its raw material suppliers and certain independent laboratory analysis conducted on the product.

CERTIFICATION

SOLBERG manufactured products are thoroughly inspected and undergo rigorous quality control tests. These evaluations analyze the foam's physical parameters as well as the finished product's fire performance. A Certificate of Analysis (CoA) is issued with every batch.

SOLBERG RE-HEALING RF3x6 ATC foam concentrate is Approved to European Standard EN 1568 Part 3 & 4 and International Civil Aviation Organization (ICAO) Airport Services Manual (DOC 9137-AN/898) Part 1 - Rescue and Firefighting, Levels B and C (6% solution) Certified.

ORDERING INFORMATION

SOLBERG RE-HEALING RF3x6 ATC foam concentrate is available in pails, drums, totes and bulk quantities.

Part No.	Description	Approximate Shipping Weight	Approximate Cube
20030	SOLBERG RE-HEALING RF3x6% ATC, 5 gallon (20 litre) pail	45 lb (21 kg)	1.25 ft ³ (0.04 m ³)
20031	SOLBERG RE-HEALING RF3x6% ATC, 55 gallon (200 litre) drum	495 lb (224 kg)	11.83 ft ³ (0.33 m ³)
20032	SOLBERG RE-HEALING RF3x6% ATC, 265 gallon (1000 litre) tote	2465 lb (1118 kg)	50.05 ft ³ (1.42 m ³)
20033	SOLBERG RE-HEALING RF3x6% ATC, bulk	Call Customer Services	



Solutions That Save.

FOR MORE INFORMATION

Contact any of our worldwide Perimeter Solutions Fire Safety offices or visit:

www.Perimeter-Solutions.com

UNITED STATES

1520 Brookfield Avenue
Green Bay, WI 54313
Tel: +1 (920) 593-9445
salesfoamusa@perimeter-solutions.com

EMEA

Polígono Industrial de Baiña, Parcela 23
33682 Baiña-Mieres (Asturias) – Spain
Tel: +34 985 24 29 45
salesfoameea@perimeter-solutions.com

ASIA PACIFIC

3 Charles Street
St Marys NSW 2760 – Australia
Tel: +61 2 9673 5300
salesfoamapac@perimeter-solutions.com

perimeter-solutions.com

NOTICE PERIMETER SOLUTIONS MAKES NO REPRESENTATIONS OR WARRANTIES AS TO THE COMPLETENESS OR ACCURACY OF THE INFORMATION INCLUDED HEREIN. THE INFORMATION CONTAINED HEREIN IS NOT INTENDED TO PROVIDE REGULATORY, LEGAL OR EXPERT ADVICE RELATING TO THE PRODUCTS, ITS APPLICATION OR USES. NOTHING CONTAINED HEREIN IS TO BE CONSTRUED AS A RECOMMENDATION TO USE ANY PRODUCT, PROCESS, EQUIPMENT OR FORMULATION IN CONFLICT WITH ANY INDUSTRIAL PROPERTY OR INTELLECTUAL PROPERTY RIGHTS, AND PERIMETER SOLUTIONS MAKES NO REPRESENTATION OR WARRANTY, EXPRESS OR IMPLIED, THAT THE USE THEREOF WILL NOT INFRINGE ON ANY INDUSTRIAL PROPERTY OR INTELLECTUAL PROPERTY RIGHTS. NO REPRESENTATIONS OR WARRANTIES, EITHER EXPRESSED OR IMPLIED, OF MERCHANTABILITY, FITNESS FOR A PARTICULAR PURPOSE OR OF ANY OTHER NATURE ARE MADE HEREUNDER WITH RESPECT TO THE INFORMATION CONTAINED HEREIN.

SOLBERG® RE-HEALING™ RF3X6% FREEZE PROTECTED ATC™ FOAM CONCENTRATE



TYPICAL PHYSICAL PROPERTIES AT 77 °F (25 °C)

Appearance: Brown liquid
Freezing Point: -2°F (-18°C)
 (No quality loss after thawing)
Maximum Storage Temp: 122°F (50°C)
pH: 7.0 - 8.5
Refractive Index: 1.3840 - 1.4140
Specific Gravity: 1.080 - 1.116
Viscosity: 4900 - 6700 cP*
Sediments: < 0.05%
 *Brookfield Viscometer Spindle #4,
 Speed 30 rpm

APPLICATION

SOLBERG RE-HEALING RF3x6 FP ATC foam concentrate is intended for use on Class B hydrocarbon or polar solvent fuel fires. The foam can be used to prevent re-ignition of a liquid spill and control hazardous vapors. On Class A fuels, SOLBERG RE-HEALING RF3x6 FP ATC foam will improve extinguishment in deep-seated fires. Foam discharge devices such as air aspirating, as well as, non-air aspirating equipment, including standard sprinkler heads, can be used to obtain maximum results. The product is mixed 3 parts foam concentrate to 97 parts water for hydrocarbon fuels or 6 parts foam concentrate to 94 parts water for polar solvent fuels. It may also be used as a pre-mix solution. SOLBERG RE-HEALING RF3x6 FP ATC foam is compatible with most dry powder (chemical) agents.

PERFORMANCE

Fire Performance

SOLBERG RE-HEALING RF3x6 FP ATC foam concentrate has been tested to and meets the fire performance test criteria of European Standard EN 1568 Part 3 & 4 (latest edition) and International Maritime Organization (IMO) MSC.1/Circ.1312 (latest edition).

Foam Proportioning

SOLBERG RE-HEALING RF3x6 FP ATC foam concentrate can be proportioned at the proper foam solution percentage using common foam proportioning devices such as:

- Eductors
- Inline balanced pressure proportioners
- Ratio controllers
- Self-educing nozzles



DESCRIPTION

SOLBERG® RE-HEALING™ RF3x6 Freeze Protected (FP) ATC™ foam concentrate from SOLBERG® is an innovative environmentally sustainable fluorosurfactant and fluoropolymer-free foam concentrate used to effectively extinguish Class B hydrocarbon fuel fires at 3% and polar solvent fuel fires at 6% solution. SOLBERG RE-HEALING RF3x6 FP ATC foam can be used in fresh, salt or brackish water. SOLBERG RE-HEALING RF3x6 FP ATC foam possesses excellent burn back resistance due to its remarkable flow and rapid resealing characteristics. RE-HEALING foam concentrates are formulated using a new high performance synthetic foam technology to replace traditional AFFF, FFFP foam concentrates and older protein and fluoroprotein foams.

STORAGE

The storage temperature range for SOLBERG RE-HEALING RF3x6 FP ATC foam concentrate is 0°F to 120°F (-18°C to 50°C).

When stored in original containers or in manufacturer recommended equipment and within the specified temperature range, the shelf life is 20 years.

COMPATIBILITY

SOLBERG RE-HEALING RF3x6 FP ATC foam concentrate should not be mixed with other foam concentrates. For questions about compatibility or mixing, consult Solberg Technical Services.

Materials of Construction Capability

SOLBERG RE-HEALING RF3x6 FP ATC foam concentrate is compatible with multiple materials of construction such as carbon steel, stainless steel, brass, polyethylene and PVC. Galvanized steel should not be used in direct contact with the foam concentrate. For questions about materials of construction compatibility, consult Solberg Technical Services.

INSPECTION

SOLBERG RE-HEALING RF3x6 FP ATC foam concentrate or pre-mix solution should be inspected annually per National Fire Protection Association (NFPA) Standards 11 and 25. A sample of the foam concentrate should be sent to the manufacturer for quality conditioning testing in accordance to NFPA 11.

SOLBERG® RE-HEALING™ RF3X6% FREEZE PROTECTED ATC™ FOAM CONCENTRATE

ENVIRONMENTAL INFORMATION

SOLBERG RE-HEALING foam concentrates are fluorosurfactant, fluoropolymer-free products for use on Class B hydrocarbon fuels with no environmental concerns for persistence, bioaccumulation or toxic break down.

CERTIFICATIONS

SOLBERG manufactured products are thoroughly inspected and undergo rigorous quality control tests. These evaluations analyze the foam's physical parameters as well as the finished product's fire performance. A Certificate of Analysis (CoA) is issued with every batch.

SOLBERG RE-HEALING RF3x6 FP ATC foam concentrate is European Standard EN 1568 Part 3 & 4 Approved, International Maritime Organization (IMO) MSC.1/Circ.1312 Approved and meets the quality and performance test requirements of LASTFIRE.

ORDERING INFORMATION

SOLBERG RE-HEALING RF3x6 FP ATC foam concentrate is available in pails, drums, totes and bulk quantities.

Part No.	Description	Approximate Shipping Weight	Approximate Cube
20280	SOLBERG RE-HEALING RF3x6 FP ATC, 5 gallon (20 litre) pail	45 lb (21 kg)	1.25 ft ³ (0.04 m ³)
20281	SOLBERG RE-HEALING RF3x6 FP ATC, 55 gallon (200 litre) drum	495 lb (224 kg)	11.83 ft ³ (0.33 m ³)
20282	SOLBERG RE-HEALING RF3x6 FP ATC, 265 gallon (1000 litre) tote	2465 lb (1118 kg)	50.05 ft ³ (1.42 m ³)
20283	SOLBERG RE-HEALING RF3x6 FP ATC, bulk	Call Customer Services	



Solutions That Save.

FOR MORE INFORMATION

Contact any of our worldwide Perimeter Solutions Fire Safety offices or visit:

www.Perimeter-Solutions.com

UNITED STATES

10667 Jersey Blvd.
Rancho Cucamonga, CA 91730

Tel: +1 800 682 3626
Tel: +1 909 983 0772

salesfoamusa@perimeter-solutions.com

EMEA

Polígono de Baiña, Parcela 23
33682 Mieres (Asturias)
Spain

Tel: +34 985 24 29 45

salesfoamea@perimeter-solutions.com

ASIA PACIFIC

3 Charles Street
St Marys NSW 2760 – Australia

Tel: +61 2 9673 5300

salesfoamapac@perimeter-solutions.com

perimeter-solutions.com

NOTICE PERIMETER SOLUTIONS MAKES NO REPRESENTATIONS OR WARRANTIES AS TO THE COMPLETENESS OR ACCURACY OF THE INFORMATION INCLUDED HEREIN. THE INFORMATION CONTAINED HEREIN IS NOT INTENDED TO PROVIDE REGULATORY, LEGAL OR EXPERT ADVICE RELATING TO THE PRODUCTS, ITS APPLICATION OR USES. NOTHING CONTAINED HEREIN IS TO BE CONSTRUED AS A RECOMMENDATION TO USE ANY PRODUCT, PROCESS, EQUIPMENT OR FORMULATION IN CONFLICT WITH ANY INDUSTRIAL PROPERTY OR INTELLECTUAL PROPERTY RIGHTS, AND PERIMETER SOLUTIONS MAKES NO REPRESENTATION OR WARRANTY, EXPRESS OR IMPLIED, THAT THE USE THEREOF WILL NOT INFRINGE ON ANY INDUSTRIAL PROPERTY OR INTELLECTUAL PROPERTY RIGHTS. NO REPRESENTATIONS OR WARRANTIES, EITHER EXPRESSED OR IMPLIED, OF MERCHANTABILITY, FITNESS FOR A PARTICULAR PURPOSE OR OF ANY OTHER NATURE ARE MADE HEREUNDER WITH RESPECT TO THE INFORMATION CONTAINED HEREIN.

SOLBERG® RE-HEALING™ TF, TRAINING FOAM CONCENTRATE



TYPICAL PHYSICAL PROPERTIES

AT 77 °F (25 °C)

Appearance: Clear liquid

Freezing Point: 23°F (-5°C)

(No quality loss after thawing)

Maximum Storage Temp: 120°F (49°C)

pH: 7.0 - 8.5

Refractive Index: 1.3555 - 1.3869

Specific Gravity: 1.005 - 1.015

Viscosity: 2-10 cSt*

Sediments: < 0.05%

*Cannon-Fenske Viscometer

APPLICATION

SOLBERG RE-HEALING TF foam concentrate is intended for use on Class B hydrocarbon fuel fires under controlled conditions for the purpose of training emergency service personnel in the use of foam and evaluating the operation of foam equipment. It is not intended for use on Class B polar solvent fuels, nor is SOLBERG RE-HEALING TF, Training Foam intended for management of actual fire situations. Foam discharge devices such as air aspirating, as well as, non-air aspirating equipment can be used to obtain maximum results. SOLBERG RE-HEALING TF foam is compatible with most dry powder (chemical) agents.

PERFORMANCE

Fire Performance

Depending on the type foam concentrate purchased. The product is mixed 1 part foam concentrate to 99 parts water or 3 parts foam concentrate to 97 parts water depending on the type concentrate utilized.

Foam Proportioning

SOLBERG RE-HEALING TF foam concentrate can be proportioned at the proper foam solution percentage using common foam proportioning devices such as:

- Eductors
- Inline balanced pressure proportioners
- Ratio controllers
- Self-educting nozzles



DESCRIPTION

SOLBERG® RE-HEALING® TF, Training Foam from SOLBERG is an innovative environmentally sustainable fluorosurfactant and fluoropolymer-free foam concentrate used to effectively extinguish Class B hydrocarbon fuel fires under controlled conditions for the purpose of training emergency service personnel in the use of foam and evaluating the operation of foam equipment. **It is not intended for management of actual fire situations.** Proportioned at either 1% or 3% solution, SOLBERG RE-HEALING TF foam concentrate can be used in fresh, salt or brackish water. SOLBERG RE-HEALING foam concentrates are formulated using a new high performance synthetic foam technology.

STORAGE

The storage temperature range for SOLBERG RE-HEALING TF foam concentrate is 35°F to 120°F (1.7°C to 49°C).

When stored in original containers or in manufacturer recommended equipment and within the specified temperature range, the shelf life is 20 years.

COMPATIBILITY

SOLBERG RE-HEALING TF foam concentrate should not be mixed with other foam concentrates. For questions about compatibility or mixing, consult Perimeter Solutions Technical Services.

Materials of Construction Capability

SOLBERG RE-HEALING TF foam concentrate is compatible with multiple materials of construction such as carbon steel, stainless steel, brass, polyethylene and PVC. Galvanized steel should not be used in direct contact with the foam concentrate. For questions about materials of construction compatibility, consult Perimeter Solutions Technical Services.

SOLBERG® RE-HEALING™ TF, TRAINING FOAM CONCENTRATE

ENVIRONMENTAL INFORMATION

SOLBERG RE-HEALING foam concentrates do not contain intentionally added PFAS chemicals including PFOA and PFOS. In making this statement, SOLBERG relies on information provided by its raw material suppliers and certain independent laboratory analysis conducted on the product.

CERTIFICATIONS

SOLBERG manufactured products are thoroughly inspected and undergo rigorous quality control tests. These evaluations analyze the foam's physical parameters as well as the finished product's fire performance. A Certificate of Analysis (CoA) is issued with every batch.

WARNING!

SOLBERG RE-HEALING TF Training Foam is used to effectively extinguish Class B hydrocarbon fuels fires under controlled conditions for the purpose of training emergency service personnel in the use of foam and evaluating the operation of foam equipment. SOLBERG RE-HEALING TF, foam concentrate is not intended for use on Class B polar solvent fuel fires nor is SOLBERG RE-HEALING TF Training Foam intended for management of actual fire situations.

ORDERING INFORMATION

SOLBERG RE-HEALING TF, foam concentrate is available in pails, drums, totes and bulk quantities.

Part No.	Description	Approximate Shipping Weight	Approximate Cube
20014	SOLBERG RE-HEALING TF1, 1% Training Foam, 5 gallon (20 litre) pail	45 lb (21 kg)	1.25 ft ³ (0.04 m ³)
20015	SOLBERG RE-HEALING TF1, 1% Training Foam, 55 gallon (200 litre) drum	495 lb (224 kg)	11.83 ft ³ (0.33 m ³)
20016	SOLBERG RE-HEALING TF1, 1% Training Foam, 265 gallon (1000 litre) tote	2465 lb (1118 kg)	50.05 ft ³ (1.42 m ³)
20017	SOLBERG RE-HEALING TF1, 1% Training Foam, bulk	Call Customer Services	
20024	SOLBERG RE-HEALING TF3, 3% Training Foam, 5 gallon (20 litre) pail	45 lb (21 kg)	1.25 ft ³ (0.04 m ³)
20025	SOLBERG RE-HEALING TF3, 3% Training Foam, 55 gallon (200 litre) drum	495 lb (224 kg)	11.83 ft ³ (0.33 m ³)
20026	SOLBERG RE-HEALING TF3, 3% Training Foam, 265 gallon (1000 litre) tote	2465 lb (1118 kg)	50.05 ft ³ (1.42 m ³)
20027	SOLBERG RE-HEALING TF3, 3% Training Foam, bulk	Call Customer Services	



Solutions That Save.

FOR MORE INFORMATION

Contact any of our worldwide Perimeter Solutions Fire Safety offices or visit:

www.Perimeter-Solutions.com

UNITED STATES

10667 Jersey Blvd.
Rancho Cucamonga, CA 91730

Tel: +1 800 682 3626
Tel: +1 909 983 0772

salesfoamusa@perimeter-solutions.com

EMEA

Polígono de Baiña, Parcela 23
33682 Mieres (Asturias)
Spain

Tel: +34 985 24 29 45

salesfoamema@perimeter-solutions.com

ASIA PACIFIC

3 Charles Street
St Marys NSW 2760 – Australia
Tel: +61 2 9673 5300

salesfoamapac@perimeter-solutions.com

perimeter-solutions.com

NOTICE PERIMETER SOLUTIONS MAKES NO REPRESENTATIONS OR WARRANTIES AS TO THE COMPLETENESS OR ACCURACY OF THE INFORMATION INCLUDED HEREIN. THE INFORMATION CONTAINED HEREIN IS NOT INTENDED TO PROVIDE REGULATORY, LEGAL OR EXPERT ADVICE RELATING TO THE PRODUCTS, ITS APPLICATION OR USES. NOTHING CONTAINED HEREIN IS TO BE CONSTRUED AS A RECOMMENDATION TO USE ANY PRODUCT, PROCESS, EQUIPMENT OR FORMULATION IN CONFLICT WITH ANY INDUSTRIAL PROPERTY OR INTELLECTUAL PROPERTY RIGHTS, AND PERIMETER SOLUTIONS MAKES NO REPRESENTATION OR WARRANTY, EXPRESS OR IMPLIED, THAT THE USE THEREOF WILL NOT INFRINGE ON ANY INDUSTRIAL PROPERTY OR INTELLECTUAL PROPERTY RIGHTS. NO REPRESENTATIONS OR WARRANTIES, EITHER EXPRESSED OR IMPLIED, OF MERCHANTABILITY, FITNESS FOR A PARTICULAR PURPOSE OR OF ANY OTHER NATURE ARE MADE HEREUNDER WITH RESPECT TO THE INFORMATION CONTAINED HEREIN.

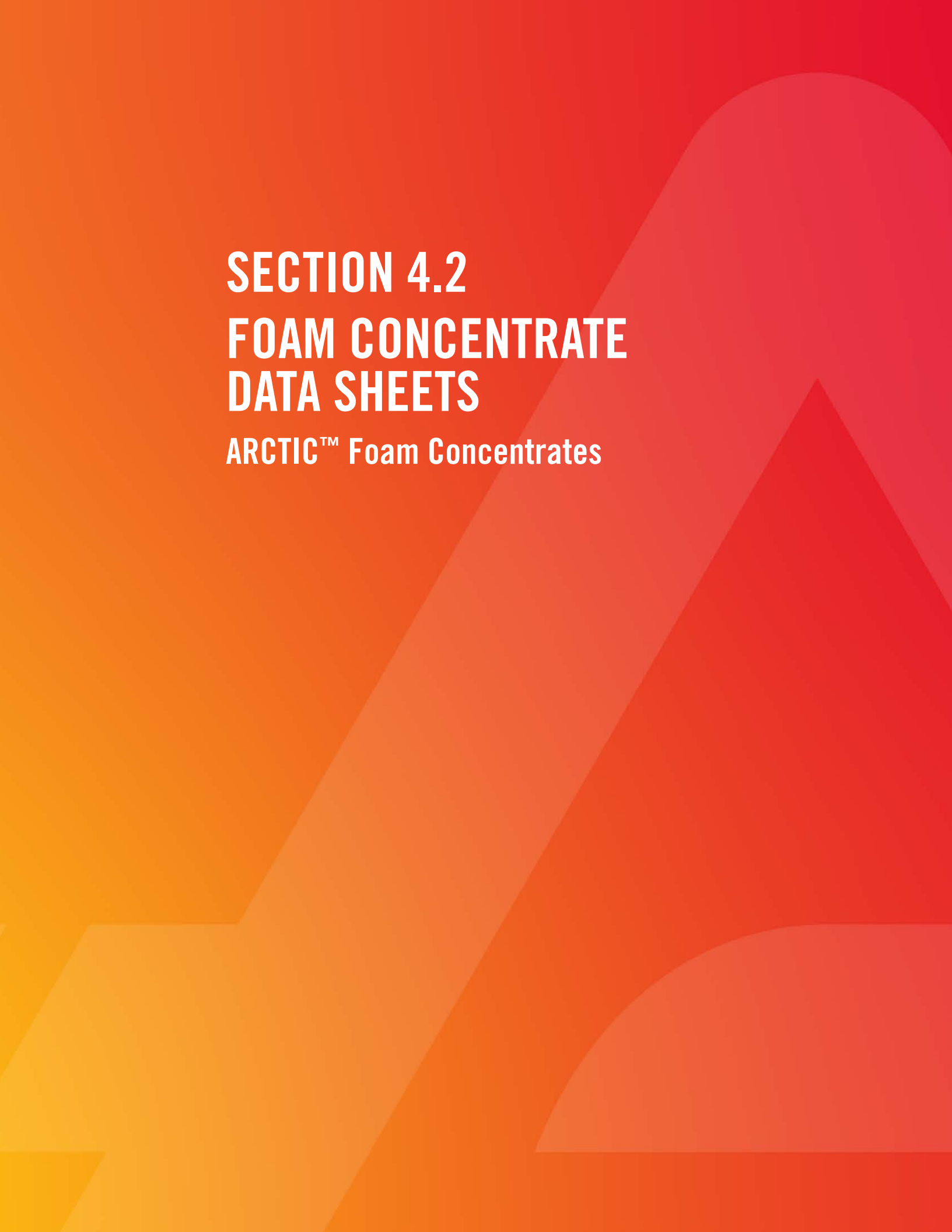
The background features a gradient from yellow-orange on the left to red on the right. Large, semi-transparent geometric shapes, including a large circle and a triangle, are overlaid on the background.

SECTION 4.2

FOAM CONCENTRATE

DATA SHEETS

ARCTIC™ Foam Concentrates

ARCTIC™ 1% AFFF FOAM CONCENTRATE



DESCRIPTION

ARCTIC™ 1% AFFF foam concentrate from SOLBERG is a synthetic foam concentrate used to effectively extinguish Class B hydrocarbon fuel fires at 1% solution. ARCTIC 1% AFFF foam concentrate provides rapid extinguishment and excellent burn back characteristics and can be used with fresh, salt and brackish water.

APPLICATION

ARCTIC 1% AFFF foam concentrate can be applied to Class B hydrocarbon fuel fires. It is not intended for use on Class B polar solvent fuels. The foam can be used to prevent re-ignition of a liquid spill and control hazardous vapors. Foam discharge devices such as non-air aspirating, as well as, air aspirating equipment, can be used to obtain maximum results. The product is mixed 1 part foam concentrate to 99 parts water. It may also be used and stored as a 1% pre-mix solution. ARCTIC 1% AFFF foam is compatible with most powder (dry chemical).

PERFORMANCE

Fire Performance

ARCTIC 1% AFFF foam concentrate has been tested to and meets the fire performance test criteria of Underwriters Laboratories, Inc. (UL) Standard 162 (latest edition), Underwriters' Laboratories of Canada (ULC) Standard S564.

Foam Proportioning

ARCTIC 1% AFFF foam concentrate can be proportioned at the proper foam solution percentage using most common proportioning devices such as:

- Eductors
- Inline balance pressure proportioners
- Ratio controllers
- Self-inducting nozzles



TYPICAL PHYSICAL PROPERTIES

at 77 °F (25 °C)

Appearance:	Clear, light yellow liquid
Freezing Point: (No quality loss after thawing)	28 °F (-2.2 °C)
Maximum storage temp:	120 °F (49 °C)
pH:	7.0 - 8.5
Refractive index:	1.3730 - 1.3785
Specific gravity:	1.050 - 1.090
Viscosity:	4.5 - 6.5 cSt*
Sediments:	<0.05%

* Cannon-Fenske Viscometer

STORAGE

The storage temperature range for ARCTIC 1% AFFF foam concentrate is 35 °F to 120 °F (1.7 °C to 49 °C).

When stored in original containers or in manufacturer recommended equipment and within the specified temperature range, the shelf life is 20 years.

COMPATIBILITY

ARCTIC 1% AFFF foam concentrate should not be mixed with other foam concentrates. For questions about compatibility or mixing of foam concentrates, consult Perimeter Solutions Technical Services.

MATERIALS OF CONSTRUCTION COMPATIBILITY

ARCTIC 1% AFFF foam concentrate is compatible with multiple materials of construction such as carbon steel, stainless steel, brass, polyethylene and PVC. Galvanized steel should not be used in direct contact with the foam concentrate. For questions about material compatibility, consult Perimeter Solutions Technical Services.

ARCTIC™ 1% AFFF FOAM CONCENTRATE

INSPECTION

ARCTIC 1% AFFF foam concentrate or pre-mix solutions should be inspected annually per National Fire Protection Association (NFPA) Standards 11 and 25. A sample of the foam concentrate should be sent to the manufacturer for quality assurance testing in accordance to NFPA 11.

CERTIFICATIONS

SOLBERG manufactured products are thoroughly inspected and undergo rigorous quality control tests. These evaluations analyze the foam's physical parameters and the finished product's fire performance. A Certificate of Analysis (CoA) is issued with every batch.

ARCTIC 1% AFFF foam concentrate is Underwriters Laboratories, Inc. Listed in accordance with UL 162 (Standard for Safety for Foam Equipment and Liquid Concentrates), Underwriters' Laboratories of Canada Listed (Standard for Category 1 Foam Liquid Concentrates ULC S564).

ORDERING INFORMATION

ARCTIC 1% AFFF foam concentrate is available in pails, drums, totes and bulk quantities.

FOAM CHAMBER - REPLACEMENT PARTS

PART NO.	DESCRIPTION	APPROXIMATE SHIPPING WEIGHT	APPROXIMATE CUBE
20120	ARCTIC 1% AFFF, 5 gallon (20 litre) pail	45 lb (21 kg)	1.25 ft ³ (0.04 m ³)
20121	ARCTIC 1% AFFF, 55 gallon (200 litre) drum	495 lb (224 kg)	11.83 ft ³ (0.33 m ³)
20122	ARCTIC 1% AFFF, 265 gallon (1000 litre) tote	2465 lb (1118 kg)	50.05 ft ³ (1.42 m ³)
20123	ARCTIC 1% AFFF, bulk	Call Customer Services	-



Solutions That Save.

FOR MORE INFORMATION

Contact any of our worldwide Perimeter Solutions Fire Safety offices or visit:

www.Perimeter-Solutions.com

UNITED STATES

10667 Jersey Blvd.
Rancho Cucamonga, CA 91730
Tel: +1 800 682 3626
Tel: +1 909 983 0772
salesfoamusa@perimeter-solutions.com

EMEA

Polígono de Baiña, Parcela 23
33682 Mieres (Asturias)
Spain
Tel: +34 985 24 29 45
salesfoamemea@perimeter-solutions.com

ASIA PACIFIC

3 Charles Street
St Marys NSW 2760 – Australia
Tel: +61 2 9673 5300
salesfoamapac@perimeter-solutions.com

perimeter-solutions.com

NOTICE PERIMETER SOLUTIONS MAKES NO REPRESENTATIONS OR WARRANTIES AS TO THE COMPLETENESS OR ACCURACY OF THE INFORMATION INCLUDED HEREIN. THE INFORMATION CONTAINED HEREIN IS NOT INTENDED TO PROVIDE REGULATORY, LEGAL OR EXPERT ADVICE RELATING TO THE PRODUCTS, ITS APPLICATION OR USES. NOTHING CONTAINED HEREIN IS TO BE CONSTRUED AS A RECOMMENDATION TO USE ANY PRODUCT, PROCESS, EQUIPMENT OR FORMULATION IN CONFLICT WITH ANY INDUSTRIAL PROPERTY OR INTELLECTUAL PROPERTY RIGHTS, AND PERIMETER SOLUTIONS MAKES NO REPRESENTATION OR WARRANTY, EXPRESS OR IMPLIED, THAT THE USE THEREOF WILL NOT INFRINGE ON ANY INDUSTRIAL PROPERTY OR INTELLECTUAL PROPERTY RIGHTS. NO REPRESENTATIONS OR WARRANTIES, EITHER EXPRESSED OR IMPLIED, OF MERCHANTABILITY, FITNESS FOR A PARTICULAR PURPOSE OR OF ANY OTHER NATURE ARE MADE HEREUNDER WITH RESPECT TO THE INFORMATION CONTAINED HEREIN.

SOLBERG® ARCTIC™ 1% FREEZE PROTECTED AFFF FOAM CONCENTRATE



DESCRIPTION

SOLBERG® ARCTIC™ 1% FP AFFF foam concentrate from SOLBERG is a synthetic freeze protected foam concentrate used to effectively extinguish Class B hydrocarbon fuel fires at 1% solution. SOLBERG ARCTIC 1% FP AFFF foam concentrate provides rapid extinguishment and excellent burn back characteristics and can be used with fresh, salt and brackish water.

APPLICATION

SOLBERG ARCTIC 1% FP AFFF foam concentrate can be applied to Class B hydrocarbon fuel fires. It is not intended for use on Class B polar solvent fuels. The foam can be used to prevent re-ignition of a liquid spill and control hazardous vapors. Foam discharge devices such as non-air aspirating, as well as, air aspirating equipment, including standard sprinkler heads, can be used to obtain maximum results. The product is mixed 1 part foam concentrate to 99 parts water. It may also be used and stored as a 1% pre-mix solution. SOLBERG ARCTIC 1% FP AFFF foam is compatible with most powder (dry chemical) agents.

PERFORMANCE

Fire Performance

SOLBERG ARCTIC 1% FP AFFF foam concentrate has been tested to and meets the fire performance test criteria of European Standard EN1568 Part 3 (latest edition) and International Maritime Organization (IMO) MSC.1/Circ. 1312 (latest edition).

Foam Proportioning

SOLBERG ARCTIC 1% FP AFFF foam concentrate can be proportioned at the proper foam solution percentage using most common proportioning devices such as:

- Eductors
- Inline balance pressure proportioners
- Ratio controllers
- Self-inducting nozzles

STORAGE

The storage temperature range for SOLBERG ARCTIC 1% FP AFFF foam concentrate is 0 °F to 120 °F (-18 °C to 49 °C).

When stored in original containers or in manufacturer recommended equipment and within the specified temperature range, the shelf life is 20 years.



TYPICAL PHYSICAL PROPERTIES

at 77 °F (25 °C)

Appearance:	Clear, light yellow liquid
Freezing Point: (No quality loss after thawing)	-4 °F (-20 °C)
Maximum storage temp:	120 °F (49 °C)
pH:	7.0 - 8.0
Refractive index:	1.3880 - 1.3970
Specific gravity:	1.055 - 1.070
Viscosity:	8 - 11 cSt*
Sediments:	None

* Cannon-Fenske Viscometer

COMPATIBILITY

SOLBERG ARCTIC 1% FP AFFF foam concentrate should not be mixed with other foam concentrates. For questions about compatibility or mixing of foam concentrates, consult Perimeter Solutions Technical Services.

MATERIALS OF CONSTRUCTION COMPATIBILITY

SOLBERG ARCTIC 1% FP AFFF foam concentrate is compatible with multiple materials of construction such as carbon steel, stainless steel, brass, polyethylene and PVC. Galvanized steel should not be used in direct contact with the foam concentrate. For questions about material compatibility, consult Perimeter Solutions Technical Services.

SOLBERG® ARCTIC™ 1% FREEZE PROTECTED AFFF FOAM CONCENTRATE

INSPECTION

SOLBERG ARCTIC 1% FP AFFF foam concentrate or pre-mix solutions should be inspected annually per National Fire Protection Association (NFPA) Standards 11 and 25. A sample of the foam concentrate should be sent to the manufacturer for quality conditioning testing in accordance to NFPA 11.

CERTIFICATIONS

SOLBERG manufactured products are thoroughly inspected and undergo rigorous quality control tests. These evaluations

analyze the foam's physical parameters and the finished product's fire performance. A Certificate of Analysis (CoA) is issued with every batch. SOLBERG ARCTIC 1% FP AFFF foam concentrate is Approved to European Standard EN1568 Part 3 and International Maritime Organization (IMO) MSC.1/Circ. 1312 Approved.

ORDERING INFORMATION

SOLBERG ARCTIC 1% FP AFFF foam concentrate is available in pails, drums, totes and bulk quantities.

FOAM CHAMBER - REPLACEMENT PARTS

PART NO.	DESCRIPTION	APPROXIMATE SHIPPING WEIGHT	APPROXIMATE CUBE
20125	SOLBERG ARCTIC 1% FP AFFF, 5 gallon (20 litre) pail	45 lb (21 kg)	1.25 ft ³ (0.04 m ³)
20126	SOLBERG ARCTIC 1% FP AFFF, 55 gallon (200 litre) drum	495 lb (224 kg)	11.83 ft ³ (0.33 m ³)
20127	SOLBERG ARCTIC 1% FP AFFF, 265 gallon (1000 litre) tote	2465 lb (1118 kg)	50.05 ft ³ (1.42 m ³)
20128	SOLBERG ARCTIC 1% FP AFFF, bulk	Call Customer Services	-



Solutions That Save.

FOR MORE INFORMATION

Contact any of our worldwide Perimeter Solutions Fire Safety offices or visit:

www.Perimeter-Solutions.com

UNITED STATES

10667 Jersey Blvd.
Rancho Cucamonga, CA 91730
Tel: +1 800 682 3626
Tel: +1 909 983 0772
salesfoamusa@perimeter-solutions.com

EMEA

Poligono de Baiña, Parcela 23
33682 Mieres (Asturias)
Spain
Tel: +34 985 24 29 45
salesfoamea@perimeter-solutions.com

ASIA PACIFIC

3 Charles Street
St Marys NSW 2760 – Australia
Tel: +61 2 9673 5300
salesfoamapac@perimeter-solutions.com

perimeter-solutions.com

NOTICE PERIMETER SOLUTIONS MAKES NO REPRESENTATIONS OR WARRANTIES AS TO THE COMPLETENESS OR ACCURACY OF THE INFORMATION INCLUDED HEREIN. THE INFORMATION CONTAINED HEREIN IS NOT INTENDED TO PROVIDE REGULATORY, LEGAL OR EXPERT ADVICE RELATING TO THE PRODUCTS, ITS APPLICATION OR USES. NOTHING CONTAINED HEREIN IS TO BE CONSTRUED AS A RECOMMENDATION TO USE ANY PRODUCT, PROCESS, EQUIPMENT OR FORMULATION IN CONFLICT WITH ANY INDUSTRIAL PROPERTY OR INTELLECTUAL PROPERTY RIGHTS, AND PERIMETER SOLUTIONS MAKES NO REPRESENTATION OR WARRANTY, EXPRESS OR IMPLIED, THAT THE USE THEREOF WILL NOT INFRINGE ON ANY INDUSTRIAL PROPERTY OR INTELLECTUAL PROPERTY RIGHTS. NO REPRESENTATIONS OR WARRANTIES, EITHER EXPRESSED OR IMPLIED, OF MERCHANTABILITY, FITNESS FOR A PARTICULAR PURPOSE OR OF ANY OTHER NATURE ARE MADE HEREUNDER WITH RESPECT TO THE INFORMATION CONTAINED HEREIN.

SOLBERG ARCTIC™ 3% AFFF FOAM CONCENTRATE



TYPICAL PHYSICAL PROPERTIES

AT 77 °F (25 °C)

Appearance: Clear light yellow liquid

Freezing Point: 28°F (-2.2°C)

(No quality loss after thawing)

Maximum Storage Temp: 120°F (49°C)

pH: 7.0 - 8.5

Refractive Index: 1.3440 - 1.3560

Specific Gravity: 1.004 - 1.045

Viscosity: 2.0 - 6.0 cSt*

Sediments: < 0.05%

* Cannon-Fenske Viscometer



APPLICATION

SOLBERG ARCTIC 3% AFFF foam concentrate can be applied to Class B hydrocarbon fuel fires. It is not intended for use on Class B polar solvent fuels. The foam can be used to prevent re-ignition of a liquid spill and control hazardous vapors. Foam discharge devices such as air aspirating, as well as, non-air aspirating equipment, including standard fire sprinkler heads, can be used to obtain maximum results. The product is mixed 3 parts foam concentrate to 97 parts water. It may also be used as a 3% pre-mix solution. ARCTIC 3% AFFF foam is compatible with most powder (dry chemical) agents.

PERFORMANCE

Fire Performance

SOLBERG ARCTIC 3% AFFF foam concentrate has been tested to and meets the fire performance test criteria of Underwriters Laboratories, Inc. (UL) Standard 162 (latest edition), Underwriters' Laboratories of Canada (ULC) Standard S564, International Civil Aviation Organization (ICAO) Level C.

Foam Proportioning

SOLBERG ARCTIC 3% AFFF foam concentrate can be proportioned at the proper foam solution percentage using most common proportioning devices such as:

- Eductors
- Inline balance pressure proportioners
- Ratio controllers
- Self-inducting nozzles

DESCRIPTION

SOLBERG ARCTIC™ 3% AFFF foam concentrate from SOLBERG is a synthetic foam concentrate used to effectively extinguish Class B hydrocarbon fuel fires at 3% solution. SOLBERG ARCTIC 3% AFFF foam provides rapid extinguishment and excellent burn back characteristics and can be used with fresh, salt and brackish water.

STORAGE

The storage temperature range for SOLBERG ARCTIC 3% AFFF foam concentrate is 35 °F to 120 °F (1.7 °C to 49 °C).

When stored in original containers or in manufacturer recommended equipment and within the specified temperature range, the shelf life is 20 years.

COMPATIBILITY

SOLBERG ARCTIC 3% AFFF foam concentrate should not be mixed with other foam concentrates. For questions about compatibility or mixing of foam concentrates, consult Perimeter Solutions Technical Services.

Materials of Construction Capability

SOLBERG ARCTIC 3% AFFF foam concentrate is compatible with multiple materials of construction such as carbon steel, stainless steel, brass, polyethylene and PVC. Galvanized steel should not be used in direct contact with the foam concentrate. For questions about material compatibility, consult Perimeter Solutions Technical Services.

INSPECTION

SOLBERG ARCTIC 3% AFFF foam concentrate or pre-mix solutions should be inspected annually per National Fire Protection Association (NFPA) Standards 11 and 25. A sample of the foam concentrate should be sent to the manufacturer for quality conditioning testing in accordance to NFPA 11.

CERTIFICATIONS

SOLBERG manufactured products are thoroughly inspected and undergo rigorous quality control tests. These evaluations analyze the foam's physical parameters and finished product's fire performance. A Certificate of Analysis (CoA) is issued with every batch.

SOLBERG ARCTIC™ 3% AFFF FOAM CONCENTRATE

SOLBERG ARCTIC 3% AFFF foam concentrate is Underwriters Laboratories, Inc. Listed in accordance with UL 162 (Standard for Safety for Foam Equipment and Liquid Concentrates), Underwriters' Laboratories of Canada Listed (Standard for Category 1 Foam Liquid Concentrates ULC S564), International Civil Aviation Organization (ICAO) Airport Services Manual (DOC 9137-AN/898) Part 1 - Rescue and Firefighting, Level C Certified.

ORDERING INFORMATION

ARCTIC 3% AFFF foam concentrate is available in pails, drums, totes and bulk quantities.

Part No.	Description	Approximate Shipping Weight	Approximate Cube
20140	ARCTIC 3% AFFF, 5 gallon (20 litre) pail	45 lb (21 kg)	1.25 ft ³ (0.04 m ³)
20141	ARCTIC 3% AFFF, 55 gallon (200 litre) drum	495 lb (224 kg)	11.83 ft ³ (0.33 m ³)
20142	ARCTIC 3% AFFF, 265 gallon (1000 litre) tote	2465 lb (1118 kg)	50.05 ft ³ (1.42 m ³)
20143	ARCTIC 3% AFFF, bulk	Call Customer Services	



Solutions That Save.

FOR MORE INFORMATION

Contact any of our worldwide Perimeter Solutions Fire Safety offices or visit:

www.Perimeter-Solutions.com

UNITED STATES

10667 Jersey Blvd.
Rancho Cucamonga, CA 91730

Tel: +1 800 682 3626
Tel: +1 909 983 0772

salesfoamusa@perimeter-solutions.com

EMEA

Polígono de Baiña, Parcela 23
33682 Mieres (Asturias)

Spain
Tel: +34 985 24 29 45

salesfoamea@perimeter-solutions.com

ASIA PACIFIC

3 Charles Street
St Marys NSW 2760 – Australia

Tel: +61 2 9673 5300

salesfoamapac@perimeter-solutions.com

perimeter-solutions.com

NOTICE PERIMETER SOLUTIONS MAKES NO REPRESENTATIONS OR WARRANTIES AS TO THE COMPLETENESS OR ACCURACY OF THE INFORMATION INCLUDED HEREIN. THE INFORMATION CONTAINED HEREIN IS NOT INTENDED TO PROVIDE REGULATORY, LEGAL OR EXPERT ADVICE RELATING TO THE PRODUCTS, ITS APPLICATION OR USES. NOTHING CONTAINED HEREIN IS TO BE CONSTRUED AS A RECOMMENDATION TO USE ANY PRODUCT, PROCESS, EQUIPMENT OR FORMULATION IN CONFLICT WITH ANY INDUSTRIAL PROPERTY OR INTELLECTUAL PROPERTY RIGHTS, AND PERIMETER SOLUTIONS MAKES NO REPRESENTATION OR WARRANTY, EXPRESS OR IMPLIED, THAT THE USE THEREOF WILL NOT INFRINGE ON ANY INDUSTRIAL PROPERTY OR INTELLECTUAL PROPERTY RIGHTS. NO REPRESENTATIONS OR WARRANTIES, EITHER EXPRESSED OR IMPLIED, OF MERCHANTABILITY, FITNESS FOR A PARTICULAR PURPOSE OR OF ANY OTHER NATURE ARE MADE HEREUNDER WITH RESPECT TO THE INFORMATION CONTAINED HEREIN.

SOLBERG® ARCTIC™ 3% DB AFFF FOAM CONCENTRATE



TYPICAL PHYSICAL PROPERTIES

AT 77 °F (25 °C)

Appearance: Clear light yellow liquid

Freezing Point: 28°F (-2.2°C)

(No quality loss after thawing)

Maximum Storage Temp: 120°F(49°C)

pH: 7.0 - 8.5

Refractive Index: 1.3450 - 1.3470

Specific Gravity: 1.010 - 1.030

Viscosity: 1.2 - 4.9 cSt*

Sediments: < 0.05%

* Cannon-Fenske Viscometer



APPLICATION

SOLBERG ARCTIC 3% DB AFFF foam concentrate can be applied to Class B hydrocarbon fuel fires. It is not intended for use on Class B polar solvent fuels. The foam can be used to prevent re-ignition of a liquid spill and control hazardous vapors. Solberg recommends that fluorine containing foam products not be used on Class A fires due to the uncontrolled release of organofluorine to the environment. However, if used on Class A fires, SOLBERG ARCTIC 3% DB AFFF foam concentrate can be proportioned at 0.5% to 3.0% which will provide superior knockdown and extinguishment over plain water. Foam discharge devices such as air aspirating, as well as, non-air aspirating equipment can be used to obtain maximum results. The product is mixed 3 parts foam concentrate to 97 parts water. It may also be used as a 3% pre-mix solution. SOLBERG ARCTIC 3% DB AFFF foam is compatible with most powder (dry chemical) agents.

DESCRIPTION

SOLBERG® ARCTIC™ 3% DB AFFF foam concentrate from SOLBERG is a synthetic foam concentrate used to effectively extinguish Class B hydrocarbon fuel fires at 3% solution. SOLBERG ARCTIC 3% DB AFFF foam provides rapid extinguishment and excellent burn back characteristics and can be used with fresh, salt and brackish water.

PERFORMANCE

Fire Performance

SOLBERG ARCTIC 3% DB AFFF foam concentrate has been tested to and meets the fire performance test criteria of Underwriters Laboratories, Inc. (UL) Standard 162 (latest edition), Underwriters' Laboratories of Canada (ULC) Standard S564 (latest edition) and European Standard EN1568 Part 3 (latest edition).

Foam Proportioning

SOLBERG ARCTIC 3% DB AFFF foam concentrate can be proportioned at the proper foam solution percentage using most common proportioning devices such as:

- Eductors
- Inline balance pressure proportioners
- Ratio controllers
- Self-inducting nozzles

STORAGE

The temperature range for SOLBERG ARCTIC 3% DB AFFF foam concentrate is 35°F to 120°F (1.7°C to 49°C).

When stored in original containers or in manufacturer recommended equipment and within the specified temperature range, the shelf life is 20 years.

SOLBERG® ARCTIC™ 3% DB AFFF FOAM CONCENTRATE

COMPATIBILITY

SOLBERG ARCTIC 3% DB AFFF foam concentrate should not be mixed with other foam concentrates. For questions about compatibility or mixing of foam concentrates, consult Perimeter Solutions Technical Services.

Materials of Construction Capability

SOLBERG ARCTIC 3% DB AFFF foam concentrate is compatible with multiple materials of construction such as carbon steel, stainless steel, brass, polyethylene and PVC. Galvanized steel should not be used in direct contact with the foam concentrate. For questions about material compatibility, consult Perimeter Solutions Technical Services.

INSPECTION

SOLBERG ARCTIC 3% DB AFFF foam concentrate or pre-mix solutions should be inspected annually per National Fire Protection Association (NFPA) Standards 11 and 25. A sample of the foam concentrate should be sent to the manufacturer for quality conditioning testing in accordance to NFPA 11.

CERTIFICATIONS

SOLBERG manufactured products are thoroughly inspected and undergo rigorous quality control tests. These evaluations analyze the foam's physical parameters and finished product's fire performance. A Certificate of Analysis (CoA) is issued with every batch.

SOLBERG ARCTIC 3% DB AFFF foam concentrate is Underwriters Laboratories, Inc. Listed in accordance with UL 162 (Standard for Safety for Foam Equipment and Liquid Concentrates), Underwriters' Laboratories of Canada Listed (Standard for Category 1 Foam Liquid Concentrates ULC S564), Approved to European Standard EN1568 Part 3.

ORDERING INFORMATION

SOLBERG ARCTIC 3% DB AFFF foam concentrate is available in pails, drums, totes and bulk quantities.

Part No.	Description	Approximate Shipping Weight	Approximate Cube
20270	SOLBERG ARCTIC 3% DB AFFF, 5 gallon (20 litre) pail	44 lb (20 kg)	1.25 ft ³ (0.04 m ³)
20271	SOLBERG ARCTIC 3% DB AFFF, 55 gallon (200 litre) drum	485 lb (220 kg)	11.83 ft ³ (0.33 m ³)
20272	SOLBERG ARCTIC 3% DB AFFF, 265 gallon (1000 litre) tote	2355 lb (1068 kg)	50.05 ft ³ (1.42 m ³)
20273	SOLBERG ARCTIC 3% DB AFFF, bulk	Call Customer Services	



Solutions That Save.

FOR MORE INFORMATION

Contact any of our worldwide Perimeter Solutions Fire Safety offices or visit:

www.Perimeter-Solutions.com

UNITED STATES

10667 Jersey Blvd.
Rancho Cucamonga, CA 91730

Tel: +1 800 682 3626
Tel: +1 909 983 0772

salesfoamusa@perimeter-solutions.com

EMEA

Polígono de Baiña, Parcela 23
33682 Mieres (Asturias)
Spain

Tel: +34 985 24 29 45

salesfoamemea@perimeter-solutions.com

ASIA PACIFIC

3 Charles Street
St Marys NSW 2760 – Australia

Tel: +61 2 9673 5300

salesfoamapac@perimeter-solutions.com

perimeter-solutions.com

NOTICE PERIMETER SOLUTIONS MAKES NO REPRESENTATIONS OR WARRANTIES AS TO THE COMPLETENESS OR ACCURACY OF THE INFORMATION INCLUDED HEREIN. THE INFORMATION CONTAINED HEREIN IS NOT INTENDED TO PROVIDE REGULATORY, LEGAL OR EXPERT ADVICE RELATING TO THE PRODUCTS, ITS APPLICATION OR USES. NOTHING CONTAINED HEREIN IS TO BE CONSTRUED AS A RECOMMENDATION TO USE ANY PRODUCT, PROCESS, EQUIPMENT OR FORMULATION IN CONFLICT WITH ANY INDUSTRIAL PROPERTY OR INTELLECTUAL PROPERTY RIGHTS, AND PERIMETER SOLUTIONS MAKES NO REPRESENTATION OR WARRANTY, EXPRESS OR IMPLIED, THAT THE USE THEREOF WILL NOT INFRINGE ON ANY INDUSTRIAL PROPERTY OR INTELLECTUAL PROPERTY RIGHTS. NO REPRESENTATIONS OR WARRANTIES, EITHER EXPRESSED OR IMPLIED, OF MERCHANTABILITY, FITNESS FOR A PARTICULAR PURPOSE OR OF ANY OTHER NATURE ARE MADE HEREUNDER WITH RESPECT TO THE INFORMATION CONTAINED HEREIN.



SOLBERG® ARCTIC™ 3% FREEZE PROTECTED AFFF FOAM CONCENTRATE

TYPICAL PHYSICAL PROPERTIES

AT 77 °F (25 °C)

- Appearance:** Clear light yellow liquid
 - Freezing Point:** -4°F (-20°C)
(No quality loss after thawing)
 - Maximum Storage Temp:** 120°F (49°C)
 - pH:** 7.0 - 8.0
 - Refractive Index:** 1.3740 - 1.3840
 - Specific Gravity:** 1.030 - 1.050
 - Viscosity:** 2 - 5 cSt*
 - Sediments:** None
- * Cannon-Fenske Viscometer

APPLICATION

SOLBERG ARCTIC 3% FP AFFF foam concentrate can be applied to Class B hydrocarbon fuel fires. It is not intended for use on Class B polar solvent fuels. The foam can be used to prevent re-ignition of a liquid spill and control hazardous vapors. Foam discharge devices such as non-air aspirating, as well as, air aspirating equipment, including standard fire sprinkler heads, can be used to obtain maximum results. The product is mixed 3 parts foam concentrate to 97 parts water. It may also be used as a 3% pre-mix solution. SOLBERG ARCTIC 3% FP AFFF foam is compatible with most powder (dry chemical) agents.

PERFORMANCE

Fire Performance

SOLBERG ARCTIC 3% FP AFFF foam concentrate has been tested to and meets the fire performance test criteria of European Standard EN 1568 Parts 3 (latest edition).

Foam Proportioning

SOLBERG ARCTIC 3% FP AFFF foam concentrate can be proportioned at the proper foam solution percentage using most common proportioning devices such as:

- Eductors
- Inline balance pressure proportioners
- Ratio controllers
- Self-inducting nozzles



DESCRIPTION

SOLBERG® ARCTIC™ 3% FP AFFF foam concentrate from SOLBERG is a synthetic freeze protected foam concentrate used to effectively extinguish Class B hydrocarbon fuel fires at 3% solution. SOLBERG ARCTIC 3% FP AFFF foam provides rapid extinguishment and excellent burn back characteristics and can be used with fresh, salt and brackish water.

STORAGE

The storage temperature range for SOLBERG ARCTIC 3% FP AFFF foam concentrate is 0°F to 120°F (-18°C to 49)

When stored in original containers or in manufacturer recommended equipment and within the specified temperature range, the shelf life is 20 years.

COMPATIBILITY

SOLBERG ARCTIC 3% FP AFFF foam concentrate should not be mixed with other foam concentrates. For questions about compatibility or mixing of foam concentrates, consult Perimeter Solutions Technical Services.

Materials of Construction Capability

SOLBERG ARCTIC 3% FP AFFF foam concentrate is compatible with multiple materials of construction such as carbon steel, stainless steel, brass, polyethylene and PVC. Galvanized steel should not be used in direct contact with the foam concentrate. For questions about material compatibility, consult Perimeter Solutions Technical Services.

INSPECTION

SOLBERG ARCTIC 3% FP AFFF foam concentrate or pre-mix solutions should be inspected annually per National Fire Protection Association (NFPA) Standards 11 and 25. A sample of the foam concentrate should be sent to the manufacturer for quality conditioning testing in accordance to NFPA 11.

CERTIFICATIONS

SOLBERG manufactured products are thoroughly inspected and undergo rigorous quality control tests. A Certificate of Analysis (CoA) is issued with every batch. SOLBERG ARCTIC 3% FP AFFF foam concentrate is Approved to European Standard EN 1568 Part 3.

SOLBERG® ARCTIC™ 3% FREEZE PROTECTED AFFF FOAM CONCENTRATE

ORDERING INFORMATION

SOLBERG ARCTIC 3% FP AFFF foam concentrate is available in pails, drums, totes and bulk quantities.

Part No.	Description	Approximate Shipping Weight	Approximate Cube
20135	SOLBERG ARCTIC 3% FP AFFF, 5 gallon (20 litre) pail	45 lb (21 kg)	1.25 ft ³ (0.04 m ³)
20136	SOLBERG ARCTIC 3% FP AFFF, 55 gallon (200 litre) drum	495 lb (224 kg)	11.83 ft ³ (0.33 m ³)
20137	SOLBERG ARCTIC 3% FP AFFF, 265 gallon (1000 litre) tote	2465 lb (1118 kg)	50.05 ft ³ (1.42 m ³)
20138	SOLBERG ARCTIC 3% FP AFFF, bulk	Call Customer Services	



Solutions That Save.

FOR MORE INFORMATION

Contact any of our worldwide Perimeter Solutions Fire Safety offices or visit:

www.Perimeter-Solutions.com

UNITED STATES

10667 Jersey Blvd.
Rancho Cucamonga, CA 91730

Tel: +1 800 682 3626
Tel: +1 909 983 0772

salesfoamusa@perimeter-solutions.com

EMEA

Polígono de Baiña, Parcela 23
33682 Mieres (Asturias)

Spain
Tel: +34 985 24 29 45

salesfoamemea@perimeter-solutions.com

ASIA PACIFIC

3 Charles Street
St Marys NSW 2760 – Australia

Tel: +61 2 9673 5300

salesfoamapac@perimeter-solutions.com

perimeter-solutions.com

NOTICE PERIMETER SOLUTIONS MAKES NO REPRESENTATIONS OR WARRANTIES AS TO THE COMPLETENESS OR ACCURACY OF THE INFORMATION INCLUDED HEREIN. THE INFORMATION CONTAINED HEREIN IS NOT INTENDED TO PROVIDE REGULATORY, LEGAL OR EXPERT ADVICE RELATING TO THE PRODUCTS, ITS APPLICATION OR USES. NOTHING CONTAINED HEREIN IS TO BE CONSTRUED AS A RECOMMENDATION TO USE ANY PRODUCT, PROCESS, EQUIPMENT OR FORMULATION IN CONFLICT WITH ANY INDUSTRIAL PROPERTY OR INTELLECTUAL PROPERTY RIGHTS, AND PERIMETER SOLUTIONS MAKES NO REPRESENTATION OR WARRANTY, EXPRESS OR IMPLIED, THAT THE USE THEREOF WILL NOT INFRINGE ON ANY INDUSTRIAL PROPERTY OR INTELLECTUAL PROPERTY RIGHTS. NO REPRESENTATIONS OR WARRANTIES, EITHER EXPRESSED OR IMPLIED, OF MERCHANTABILITY, FITNESS FOR A PARTICULAR PURPOSE OR OF ANY OTHER NATURE ARE MADE HEREUNDER WITH RESPECT TO THE INFORMATION CONTAINED HEREIN.



ARCTIC™ 1x3% ATC™ FOAM CONCENTRATE

TYPICAL PHYSICAL PROPERTIES

AT 77 °F (25 °C)

Appearance: Light yellow

non-newtonian liquid

Freezing Point: 28°F (-2.2°C)

(No quality loss after thawing)

Maximum Storage Temp: 120°F (49°C)

pH: 7.0 - 8.5

Refractive Index: 1.3624 - 1.3674

Specific Gravity: 1.005 - 1.055

Viscosity: 2400 - 3400 cP*

Sediments: < 0.05%

* Brookfield Viscometer Spindle #4,
Speed 30 rpm

APPLICATION

ARCTIC 1x3 ATC foam concentrate can be applied to either Class B hydrocarbon or polar solvent fuel fires. The product is mixed 1 part foam concentrate to 99 parts water for hydrocarbon fuels or 3 parts foam concentrate to 97 parts water for polar solvent fuels. It may also be used as either a 1% or 3% pre-mix solution. The foam can be used to prevent re-ignition of a liquid spill and control hazardous vapors. Foam discharge devices such as air aspirating, as well as, non-air aspirating equipment can be used to obtain maximum results. ARCTIC 1x3 ATC foam is compatible with most powder (dry chemical) agents.

PERFORMANCE

Fire Performance

ARCTIC 1x3 ATC foam concentrate has been tested to and meets the fire performance test criteria of Underwriters Laboratories, Inc. (UL) Standard 162 (latest edition), Underwriters' Laboratories of Canada (ULC) Standard S564 and European Standard EN1568 Parts 3 & 4 (latest edition).

Foam Proportioning

ARCTIC 1x3 ATC foam concentrate can be proportioned at the proper foam solution percentage using most common proportioning devices such as:

- Eductors
- Inline balance pressure proportioners
- Ratio controllers
- Self-inducting nozzles



DESCRIPTION

ARCTIC™ 1x3 ATC™ foam concentrate from SOLBERG is a synthetic, alcohol-resistant foam concentrate used to effectively extinguish Class B hydrocarbon fuel fires at 1% and polar solvent fuel fires at 3%. ARCTIC 1x3 ATC foam provides rapid extinguishment and excellent burn back characteristics and can be proportioned at 1% or 3% solution in fresh, salt and brackish water.

STORAGE

The storage temperature range for ARCTIC 1x3 ATC foam concentrate is 35°F to 120°F (1.7°C to 49°C).

When stored in original containers or in manufacturer recommended equipment and within the specified temperature range, the shelf life is 20 years.

COMPATIBILITY

ARCTIC 1x3 ATC foam concentrate should not be mixed with other foam concentrates. For questions about compatibility or mixing of foam concentrates, consult Perimeter Solutions Technical Services.

Materials of Construction Capability

SOLBERG ARCTIC 1x3 ATC foam concentrate is compatible with multiple materials of construction like carbon steel, stainless steel, brass, polyethylene and PVC. Galvanized steel should not be used in direct contact with the foam concentrate. For questions about material compatibility, consult Perimeter Solutions Technical Services.

INSPECTION

ARCTIC 1x3 ATC foam concentrate or pre-mix solutions should be inspected annually per National Fire Protection Association (NFPA) Standards 11 and 25. A sample of the foam concentrate should be sent to the manufacturer for quality conditioning testing in accordance to NFPA 11.

CERTIFICATIONS

SOLBERG manufactured products are thoroughly inspected and undergo rigorous quality control tests. These evaluations analyze the foam's physical parameters and the finished product's fire performance. A Certificate of Analysis (CoA) is issued with every batch.

ARCTIC 1x3 ATC foam concentrate is Underwriters Laboratories, Inc. Listed in accordance with UL 162 (Standard for Safety for Foam Equipment and Liquid Concentrates), Underwriters' Laboratories of Canada Listed (Standard for Category

ARCTIC™ 1X3% ATC™ FOAM CONCENTRATE

1 and 2 Foam Liquid Concentrates ULC S564), Approved to European Standard EN 1568 Parts 3 & 4, and meets the quality and performance test requirements of LASTFIRE.

ORDERING INFORMATION

ARCTIC 1x3 ATC foam concentrate is available in pails, drums, totes and bulk quantities.

ORDERING INFORMATION

Part No.	Description	Approximate Shipping Weight	Approximate Cube
20100	ARCTIC 1x3 ATC, 5 gallon (20 litre) pail	45 lb (21 kg)	1.25 ft ³ (0.04 m ³)
20101	ARCTIC 1x3 ATC, 55 gallon (200 litre) drum	495 lb (224 kg)	11.83 ft ³ (0.33 m ³)
20102	ARCTIC 1x3 ATC, 265 gallon (1000 litre) tote	2465 lb (1118 kg)	50.05 ft ³ (1.42 m ³)
20103	ARCTIC 1x3 ATC, bulk	Call Customer Services	



Solutions That Save.

FOR MORE INFORMATION

Contact any of our worldwide Perimeter Solutions Fire Safety offices or visit:

www.Perimeter-Solutions.com

UNITED STATES

10667 Jersey Blvd.
Rancho Cucamonga, CA 91730

Tel: +1 800 682 3626
Tel: +1 909 983 0772

salesfoamusa@perimeter-solutions.com

EMEA

Polígono de Baiña, Parcela 23
33682 Mieres (Asturias)

Spain
Tel: +34 985 24 29 45

salesfoamemea@perimeter-solutions.com

ASIA PACIFIC

3 Charles Street
St Marys NSW 2760 – Australia

Tel: +61 2 9673 5300

salesfoamapac@perimeter-solutions.com

perimeter-solutions.com

NOTICE PERIMETER SOLUTIONS MAKES NO REPRESENTATIONS OR WARRANTIES AS TO THE COMPLETENESS OR ACCURACY OF THE INFORMATION INCLUDED HEREIN. THE INFORMATION CONTAINED HEREIN IS NOT INTENDED TO PROVIDE REGULATORY, LEGAL OR EXPERT ADVICE RELATING TO THE PRODUCTS, ITS APPLICATION OR USES. NOTHING CONTAINED HEREIN IS TO BE CONSTRUED AS A RECOMMENDATION TO USE ANY PRODUCT, PROCESS, EQUIPMENT OR FORMULATION IN CONFLICT WITH ANY INDUSTRIAL PROPERTY OR INTELLECTUAL PROPERTY RIGHTS, AND PERIMETER SOLUTIONS MAKES NO REPRESENTATION OR WARRANTY, EXPRESS OR IMPLIED, THAT THE USE THEREOF WILL NOT INFRINGE ON ANY INDUSTRIAL PROPERTY OR INTELLECTUAL PROPERTY RIGHTS. NO REPRESENTATIONS OR WARRANTIES, EITHER EXPRESSED OR IMPLIED, OF MERCHANTABILITY, FITNESS FOR A PARTICULAR PURPOSE OR OF ANY OTHER NATURE ARE MADE HEREUNDER WITH RESPECT TO THE INFORMATION CONTAINED HEREIN.

ARCTIC™ 1x3% FREEZE PROTECTED ATC™ FOAM CONCENTRATE

TYPICAL PHYSICAL PROPERTIES

AT 77 °F (25 °C)

Appearance: Pale straw colored gelled liquid

Freezing Point: -25°F (-32°C)
(No quality loss after thawing)

Maximum Storage Temp: 120°F (49°C)

pH: 7.0 - 8.5

Refractive Index: 1.3960 - 1.4010

Specific Gravity: 1.032 - 1.072

Viscosity: 2300 - 3300 cP*

Sediments: < 0.05%

* Brookfield Viscometer Spindle #4,
Speed 30 rpm

APPLICATION

ARCTIC 1x3 FP ATC foam concentrate can be applied to either Class B hydrocarbon or polar solvent fuel fires. The product is mixed 1 part foam concentrate to 99 parts water for hydrocarbon fuels or 3 parts foam concentrate to 97 parts water for polar solvent fuels. It may also be used as either a 1% or 3% pre-mix solution. The foam can be used to prevent re-ignition of a liquid spill and control hazardous vapors. Foam discharge devices such as non-air aspirating, as well as, air aspirating ARCTIC™ 1x3% FREEZE PROTECTED ATC™ FOAM CONCENTRATE equipment can be used to obtain maximum results. ARCTIC 1x3 FP ATC foam is compatible with most powder (dry chemical) agents.

PERFORMANCE

Foam Proportioning

ARCTIC 1x3 FP ATC foam concentrate can be proportioned at the proper foam solution percentage using most common proportioning devices such as:

- Eductors
- Inline balance pressure proportioners
- Ratio controllers
- Self-inducting nozzles



DESCRIPTION

ARCTIC™ 1x3 FP ATC™ foam concentrate is a freeze protected, synthetic, alcohol-resistant foam concentrate used to effectively extinguish Class B hydrocarbon fuel fires at 1% and polar solvent fuel fires at 3%. ARCTIC 1x3 FP ATC foam provides rapid extinguishment and excellent burn back characteristics and can be proportioned at 1% or 3% solution in fresh, salt and brackish water.

STORAGE

The storage temperature range for ARCTIC 1x3 FP ATC foam concentrate is -20 °F to 120 °F (-29 °C to 49 °C).

When stored in original containers or in manufacturer recommended equipment and within the specified temperature range, the shelf life is 20 years.

COMPATIBILITY

ARCTIC 1x3 FP ATC foam concentrate should not be mixed with other foam concentrates. For questions about compatibility or mixing of foam concentrates, consult Perimeter Solutions Technical Services.

Materials of Construction Capability

ARCTIC 1x3 FP ATC foam concentrate is compatible with multiple materials of construction like carbon steel, stainless steel, brass, polyethylene and PVC. Galvanized steel should not be used in direct contact with the foam concentrate. For questions about material compatibility, consult Perimeter Solutions Technical Services.

INSPECTION

ARCTIC 1x3 FP ATC foam concentrate or pre-mix solutions should be inspected annually per National Fire Protection Association (NFPA) Standards 11 and 25. A sample of the foam concentrate should be sent to the manufacturer for quality conditioning testing in accordance to NFPA 11.

CERTIFICATIONS

Solberg manufactured products are thoroughly inspected and undergo rigorous quality control tests. These evaluations analyze the foam's physical parameters and the finished product's fire performance. A Certificate of Analysis (CoA) is issued with every batch.

ARCTIC™ 1X3% FREEZE PROTECTED ATC™ FOAM CONCENTRATE

ORDERING INFORMATION

ARCTIC 1x3 FP ATC foam concentrate is available in pails, drums, totes and bulk quantities.

ORDERING INFORMATION

Part No.	Description	Approximate Shipping Weight	Approximate Cube
20250	ARCTIC 1x3 FP ATC, 5 gallon (20 litre) pail	45 lb (21 kg)	1.25 ft ³ (0.04 m ³)
20251	ARCTIC 1x3 FP ATC, 55 gallon (200 litre) drum	495 lb (224 kg)	11.83 ft ³ (0.33 m ³)
20252	ARCTIC 1x3 FP ATC, 265 gallon (1000 litre) tote	2465 lb (1118 kg)	50.05 ft ³ (1.42 m ³)
20253	ARCTIC FP 1x3 ATC, bulk	Call Customer Services	



Solutions That Save.

FOR MORE INFORMATION

Contact any of our worldwide Perimeter Solutions Fire Safety offices or visit:

www.Perimeter-Solutions.com

UNITED STATES

10667 Jersey Blvd.
Rancho Cucamonga, CA 91730

Tel: +1 800 682 3626
Tel: +1 909 983 0772

salesfoamusa@perimeter-solutions.com

EMEA

Polígono de Baiña, Parcela 23
33682 Mieres (Asturias)

Spain
Tel: +34 985 24 29 45

salesfoamea@perimeter-solutions.com

ASIA PACIFIC

3 Charles Street
St Marys NSW 2760 – Australia

Tel: +61 2 9673 5300

salesfoamapac@perimeter-solutions.com

perimeter-solutions.com

NOTICE PERIMETER SOLUTIONS MAKES NO REPRESENTATIONS OR WARRANTIES AS TO THE COMPLETENESS OR ACCURACY OF THE INFORMATION INCLUDED HEREIN. THE INFORMATION CONTAINED HEREIN IS NOT INTENDED TO PROVIDE REGULATORY, LEGAL OR EXPERT ADVICE RELATING TO THE PRODUCTS, ITS APPLICATION OR USES. NOTHING CONTAINED HEREIN IS TO BE CONSTRUED AS A RECOMMENDATION TO USE ANY PRODUCT, PROCESS, EQUIPMENT OR FORMULATION IN CONFLICT WITH ANY INDUSTRIAL PROPERTY OR INTELLECTUAL PROPERTY RIGHTS, AND PERIMETER SOLUTIONS MAKES NO REPRESENTATION OR WARRANTY, EXPRESS OR IMPLIED, THAT THE USE THEREOF WILL NOT INFRINGE ON ANY INDUSTRIAL PROPERTY OR INTELLECTUAL PROPERTY RIGHTS. NO REPRESENTATIONS OR WARRANTIES, EITHER EXPRESSED OR IMPLIED, OF MERCHANTABILITY, FITNESS FOR A PARTICULAR PURPOSE OR OF ANY OTHER NATURE ARE MADE HEREUNDER WITH RESPECT TO THE INFORMATION CONTAINED HEREIN.



ARCTIC™ 3X3% ATC™ FOAM CONCENTRATE

TYPICAL PHYSICAL PROPERTIES

AT 77 °F (25 °C)

Appearance: Light yellow
non-newtonian liquid

Freezing Point: 28 °F (-2.2 °C)
(No quality loss after thawing)

Maximum Storage Temp: 120 °F (49 °C)

pH: 7.0 - 8.5

Refractive Index: 1.3545 - 1.3595

Specific Gravity: 1.000 - 1.040

Viscosity: 2400 - 3400 cP*

Sediments: <0.05%

*Brookfield Viscometer Spindle #4,
Speed 30 rpm



DESCRIPTION

ARCTIC™ 3x3 ATC™ foam concentrate from SOLBERG® is a synthetic, alcohol-resistant foam concentrate used to effectively extinguish Class B hydrocarbon and polar solvent fuel fires at 3% solution. ARCTIC 3x3 ATC foam concentrate provides rapid extinguishment and excellent burn back characteristics and can be used with fresh, salt and brackish water.

STORAGE

The storage temperature range for ARCTIC 3x3 ATC foam concentrate is 35 °F to 120 °F (1.7 °C to 49 °C).

When stored in original containers or in manufacturer recommended equipment and within the specified temperature range, the shelf life is 20 years.

COMPATIBILITY

ARCTIC 3x3 ATC foam concentrate should not be mixed with other foam concentrates. For questions about compatibility or mixing of foam concentrates, consult Perimeter Solutions Technical Services.

Materials of Construction Capability

ARCTIC 3x3 ATC foam concentrate is compatible with multiple materials of construction such as carbon steel, stainless steel, brass, polyethylene and PVC. Galvanized steel should not be used in direct contact with the foam concentrate.

INSPECTION

ARCTIC 3x3 ATC foam concentrate or pre-mix solutions should be inspected annually per National Fire Protection Association (NFPA) Standards 11 and 25.

A sample of the foam concentrate should be sent to the manufacturer for quality conditioning testing in accordance to NFPA 11.

ENVIRONMENTAL INFORMATION

ARCTIC 3x3 ATC foam concentrate is formulated with C6 fluorosurfactants.

CERTIFICATIONS

Solberg manufactured products are thoroughly inspected and undergo rigorous quality control tests. These evaluations analyze the foam's physical parameters and the finished product's fire performance. A Certificate of Analysis (CoA) is issued with every batch.

ARCTIC 3x3 ATC foam concentrate is Underwriters Laboratories, Inc. Listed in accordance with UL 162 (Standard for Safety for Foam Equipment and Liquid Concentrates), Underwriters' Laboratories of Canada Listed (Standard for Category 1 and 2 Foam Liquid Concentrates ULC S564) and FM Approved per Approval Standard 5130.

APPLICATION

ARCTIC 3x3 ATC foam concentrate can be applied to either Class B hydrocarbon or polar solvent^{††} fuel fires. The product is mixed 3 parts foam concentrate to 97 parts water. It may also be used as a 3% pre-mix solution. The foam can be used to prevent reignition of a liquid spill and control hazardous vapors. Foam discharge devices such as air aspirating, as well as, non-air aspirating equipment including standard fire sprinkler heads, can be used to obtain maximum results. ARCTIC 3x3 ATC foam is compatible with most powder (dry chemical) agents.[†]

PERFORMANCE

Fire Performance

ARCTIC 3x3 ATC foam concentrate has been tested to and meets the fire performance test criteria of Underwriters Laboratories, Inc. (UL) Listed – Standard 162 Underwriters' Laboratories of Canada (ULC) Standard S564 and FM Approval Standard 5130.

Foam Proportioning

ARCTIC 3x3 ATC foam concentrate can be proportioned at the proper foam solution percentage using most common proportioning devices^{††} such as:

- Eductors
- Inline balance pressure proportioners
- Ratio controllers
- Self-inducting nozzles

[†]Not an FM Approved Configuration

^{††}See FM Approval Guide

ARCTIC™ 3X3% ATC™ FOAM CONCENTRATE

ORDERING INFORMATION

ARCTIC 3x3 ATC foam concentrate is available in pails, drums, totes and bulk quantities.

Part No.	Description	Approximate Shipping Weight	Approximate Cube
20080	ARCTIC 3x3 ATC, 5 gallon (20 litre) pail	45 lb (21 kg)	1.25 ft ³ (0.04 m ³)
20081	ARCTIC 3x3 ATC, 55 gallon (200 litre) drum	495 lb (224 kg)	11.83 ft ³ (0.33 m ³)
20082	ARCTIC 3x3 ATC, 265 gallon (1000 litre) tote	2465 lb (1118 kg)	50.05 ft ³ (1.42 m ³)
20083	ARCTIC 3x3 ATC, bulk	Call Customer Services	



Solutions That Save.

FOR MORE INFORMATION

Contact any of our worldwide Perimeter Solutions Fire Safety offices or visit:

www.Perimeter-Solutions.com

UNITED STATES

10667 Jersey Blvd.
Rancho Cucamonga, CA 91730
Tel: +1 800 682 3626
Tel: +1 909 983 0772
salesfoamusa@perimeter-solutions.com

EMEA

Polígono de Baiña, Parcela 23
33682 Mieres (Asturias)
Spain
Tel: +34 985 24 29 45
salesfoamemea@perimeter-solutions.com

ASIA PACIFIC

3 Charles Street
St Marys NSW 2760 – Australia
Tel: +61 2 9673 5300
salesfoamapac@perimeter-solutions.com

perimeter-solutions.com

NOTICE PERIMETER SOLUTIONS MAKES NO REPRESENTATIONS OR WARRANTIES AS TO THE COMPLETENESS OR ACCURACY OF THE INFORMATION INCLUDED HEREIN. THE INFORMATION CONTAINED HEREIN IS NOT INTENDED TO PROVIDE REGULATORY, LEGAL OR EXPERT ADVICE RELATING TO THE PRODUCTS, ITS APPLICATION OR USES. NOTHING CONTAINED HEREIN IS TO BE CONSTRUED AS A RECOMMENDATION TO USE ANY PRODUCT, PROCESS, EQUIPMENT OR FORMULATION IN CONFLICT WITH ANY INDUSTRIAL PROPERTY OR INTELLECTUAL PROPERTY RIGHTS, AND PERIMETER SOLUTIONS MAKES NO REPRESENTATION OR WARRANTY, EXPRESS OR IMPLIED, THAT THE USE THEREOF WILL NOT INFRINGE ON ANY INDUSTRIAL PROPERTY OR INTELLECTUAL PROPERTY RIGHTS. NO REPRESENTATIONS OR WARRANTIES, EITHER EXPRESSED OR IMPLIED, OF MERCHANTABILITY, FITNESS FOR A PARTICULAR PURPOSE OR OF ANY OTHER NATURE ARE MADE HEREUNDER WITH RESPECT TO THE INFORMATION CONTAINED HEREIN.

SOLBERG ARCTIC™ 3X6% ATC™ FOAM CONCENTRATE



TYPICAL PHYSICAL PROPERTIES

AT 77 °F (25 °C)

Appearance: Clear light yellow liquid

Freezing Point: -31°F (-1°C)

(No quality loss after thawing)

Maximum Storage Temp: 120°F (49°C)

pH: 7.0 - 8.5

Refractive Index: 1.3440 - 1.3490

Specific Gravity: 1.009 - 1.025

Viscosity: 2100 - 2900 cP*

Sediments: None

*Brookfield Viscometer Spindle #4,
Speed 30 rpm

APPLICATION

ARCTIC 3X6 ATC foam concentrate can be applied to either Class B hydrocarbon or polar solvent fuel fires. The product is mixed 3 parts foam concentrate to 97 parts water for hydrocarbon fuels or 6 parts foam concentrates to 94 parts water for polar solvent fuels. The foam can be used to prevent re-ignition of a liquid spill and control hazardous vapors. Foam discharge devices such as air aspirating, as well as, non-air aspirating equipment, including standard fire sprinkler heads, can be used to obtain maximum results. ARCTIC 3X6 ATC foam is compatible with most powder (dry chemical) agents.

PERFORMANCE

Fire Performance

ARCTIC 3X6 ATC foam concentrate has been tested to and meets the fire performance test criteria of Underwriters Laboratories, Inc. (UL) Standard 162 (latest edition), Underwriters' Laboratories of Canada (ULC) Standard S564 (latest edition).

Foam Proportioning

ARCTIC 3X6 ATC foam concentrate can be proportioned at the proper foam solution percentage using most common proportioning devices such as:

- Eductors
- Inline balance pressure proportioners
- Ratio controllers
- Self-inducting nozzles



DESCRIPTION

ARCTIC™ 3X6 ATC™ foam concentrate from Solberg is a synthetic alcohol-resistant foam concentrate used to effectively extinguish Class B hydrocarbon fuel fires at 3% and polar solvent fuel fires at 6% solution. ARCTIC 3X6 ATC foam concentrate provides rapid extinguishment and excellent burn back characteristics and can be used with fresh, sea and brackish water.

STORAGE

The storage temperature range for ARCTIC 3X6 ATC foam concentrate is 35°F to 120°F (2°C to 49°C).

When stored in original containers or in manufacturer recommended equipment and within the specified temperature range, the shelf life is 20 years.

COMPATIBILITY

ARCTIC 3X6 ATC foam concentrate should not be mixed with other foam concentrates. For questions about compatibility or mixing of foam concentrates, consult Perimeter Solutions Technical Services.

Materials of Construction Capability

ARCTIC 3X6 ATC foam concentrate is compatible with multiple materials of construction such as carbon steel, stainless steel, brass, polyethylene and PVC. Galvanized steel should not be used in direct contact with the foam concentrate. For questions about material compatibility, consult Perimeter Solutions Technical Services.

INSPECTION

ARCTIC 3X6 ATC foam concentrate or pre-mix solutions should be inspected annually per National Fire Protection Association (NFPA) Standards 11 and 25. A sample of the foam concentrate should be sent to the manufacturer for quality conditioning testing in accordance to NFPA 11.

CERTIFICATIONS

Solberg manufactured products are thoroughly inspected and undergo rigorous quality control tests. These evaluations analyze the foam's physical parameters and finished product's fire performance. A Certificate of Analysis (CoA) is issued with every batch.

ARCTIC™ 3X6% ATC™ FOAM CONCENTRATE

ARCTIC 3X6 ATC foam concentrate is Underwriters Laboratories, Inc. Listed in accordance with UL 162 (Standard for Safety for Foam Equipment and Liquid Concentrates), Underwriters' Laboratories of Canada Listed (Standard for Category 1 and 2 Foam Liquid Concentrates ULC S564).

ORDERING INFORMATION

ARCTIC 3x6% ATC foam concentrate is available in pails, drums, totes and bulk quantities.

ORDERING INFORMATION

Part No.	Description	Approximate Shipping Weight	Approximate Cube
20260	ARCTIC 3X6 ATC, 5 gallon (20 litre) pail	45 lb (21 kg)	1.25 ft ³ (0.04 m ³)
20261	ARCTIC 3X6 ATC, 55 gallon (200 litre) drum	495 lb (224 kg)	11.83 ft ³ (0.33 m ³)
20262	ARCTIC 3X6 ATC, 265 gallon (1000 litre) tote	2465 lb (1118 kg)	50.05 ft ³ (1.42 m ³)
20263	ARCTIC 3X6 ATC, bulk	Call Customer Services	



Solutions That Save.

FOR MORE INFORMATION

Contact any of our worldwide Perimeter Solutions Fire Safety offices or visit:

www.Perimeter-Solutions.com

UNITED STATES

10667 Jersey Blvd.
Rancho Cucamonga, CA 91730

Tel: +1 800 682 3626

Tel: +1 909 983 0772

salesfoamusa@perimeter-solutions.com

EMEA

Polígono de Baiña, Parcela 23
33682 Mieres (Asturias)

Spain

Tel: +34 985 24 29 45

salesfoamemea@perimeter-solutions.com

ASIA PACIFIC

3 Charles Street
St Marys NSW 2760 – Australia

Tel: +61 2 9673 5300

salesfoamapac@perimeter-solutions.com

perimeter-solutions.com

NOTICE PERIMETER SOLUTIONS MAKES NO REPRESENTATIONS OR WARRANTIES AS TO THE COMPLETENESS OR ACCURACY OF THE INFORMATION INCLUDED HEREIN. THE INFORMATION CONTAINED HEREIN IS NOT INTENDED TO PROVIDE REGULATORY, LEGAL OR EXPERT ADVICE RELATING TO THE PRODUCTS, ITS APPLICATION OR USES. NOTHING CONTAINED HEREIN IS TO BE CONSTRUED AS A RECOMMENDATION TO USE ANY PRODUCT, PROCESS, EQUIPMENT OR FORMULATION IN CONFLICT WITH ANY INDUSTRIAL PROPERTY OR INTELLECTUAL PROPERTY RIGHTS, AND PERIMETER SOLUTIONS MAKES NO REPRESENTATION OR WARRANTY, EXPRESS OR IMPLIED, THAT THE USE THEREOF WILL NOT INFRINGE ON ANY INDUSTRIAL PROPERTY OR INTELLECTUAL PROPERTY RIGHTS. NO REPRESENTATIONS OR WARRANTIES, EITHER EXPRESSED OR IMPLIED, OF MERCHANTABILITY, FITNESS FOR A PARTICULAR PURPOSE OR OF ANY OTHER NATURE ARE MADE HEREUNDER WITH RESPECT TO THE INFORMATION CONTAINED HEREIN.

SOLBERG® ARCTIC™ 3X6% LOW VISCOSITY ATC™ FOAM CONCENTRATE



TYPICAL PHYSICAL PROPERTIES

AT 77 °F (25 °C)

Appearance: Clear, light yellow liquid

Freezing Point: 19°F (-7°C)

(No quality loss after thawing)

Maximum Storage Temp: 120°F (49°C)

pH: 7.0 - 8.0

Refractive Index: 1.3450 - 1.3535

Specific Gravity: 1.020 - 1.035

Viscosity: 9 - 12 cSt*

Sediments: None

*Cannon - Fenske Viscometer



APPLICATIONS

SOLBERG ARCTIC 3X6 LV ATC foam concentrate can be applied to either Class B hydrocarbon or polar solvent fuel fires. The product is mixed 3 parts foam concentrate to 97 parts water for hydrocarbon fuels or 6 parts foam concentrates to 94 parts water for polar solvent fuels. The foam can be used to prevent re-ignition of a liquid spill and control hazardous vapors. Foam non-air aspirating, as well as air aspirating equipment, including standard fire sprinkler heads, can be used to obtain maximum results. SOLBERG ARCTIC 3X6 LV ATC foam is compatible with most powder (dry chemical) agents.

PERFORMANCE

Fire Performance

SOLBERG ARCTIC 3X6 LV ATC foam concentrate has been tested to and meets the fire performance test criteria of the International Maritime Organization (IMO) MSC.1/Circ.1312 (latest edition).

Foam Proportioning

SOLBERG ARCTIC 3X6 LV ATC foam concentrate can be proportioned at the proper foam solution percentage using most common proportioning devices such as:

- Eductors
- Inline balance pressure proportioners
- Ratio controllers
- Self-inducting nozzles

DESCRIPTION

SOLBERG® ARCTIC™ 3X6 LV ATC™ foam concentrate from SOLBERG is a synthetic alcohol-resistant foam concentrate used to effectively extinguish Class B hydrocarbon fuel fires at 3% and polar solvent fuel fires at 6% solution. SOLBERG ARCTIC 3X6 LV ATC foam concentrate provides rapid extinguishment and excellent burn back characteristics and can be used with fresh, sea and brackish water.

STORAGE

The storage temperature range for SOLBERG ARCTIC 3x6 LV ATC foam concentrate is 23°F to 120°F (-5°C to 49°C).

When stored in original containers or in manufacturer recommended equipment and within the specified temperature range, the shelf life is 20 years.

COMPATIBILITY

SOLBERG ARCTIC 3X6 LV ATC foam concentrate should not be mixed with other foam concentrates. For questions about compatibility or mixing of foam concentrates, consult Perimeter Solutions Technical Services.

Materials of Construction Capability

SOLBERG ARCTIC 3X6 LV ATC foam concentrate is compatible with multiple materials of construction such as carbon steel, stainless steel, brass, polyethylene and PVC. Galvanized steel should not be used in direct contact with the foam concentrate. For questions about material compatibility, consult Perimeter Solutions Technical Services.

INSPECTION

SOLBERG ARCTIC 3X6 LV ATC foam concentrate or pre-mix solutions should be inspected annually per National Fire Protection Association (NFPA) Standards 11 and 25. A sample of the foam concentrate should be sent to the manufacturer for quality conditioning testing in accordance to NFPA 11.

SOLBERG® ARCTIC™ 3X6% LOW VISCOSITY ATC™ FOAM CONCENTRATE

CERTIFICATIONS

SOLBERG manufactured products are thoroughly inspected and undergo rigorous quality control tests. These evaluations analyze the foam's physical parameters and finished product's fire performance. A Certificate of Analysis (CoA) is issued with every batch.

SOLBERG ARCTIC 3X6 LV ATC foam concentrate is International Maritime Organization (IMO) MSC.1/Circ.1312 Approved.

ORDERING INFORMATION

SOLBERG ARCTIC 3x6% LV ATC foam concentrate is available in pails, drums, totes and bulk quantities.

Part No.	Description	Approximate Shipping Weight	Approximate Cube
29294	SOLBERG ARCTIC 3X6 LV ATC, 5 gallon (20 litre) pail	45 lb (21 kg)	1.25 ft ³ (0.04 m ³)
29295	SOLBERG ARCTIC 3X6 LV ATC, 55 gallon (200 litre) drum	495 lb (224 kg)	11.83 ft ³ (0.33 m ³)
29296	SOLBERG ARCTIC 3X6 LV ATC, 265 gallon (1000 litre) tote	2465 lb (1118 kg)	50.05 ft ³ (1.42 m ³)
29297	SOLBERG ARCTIC 3X6 LV ATC, bulk	Call Customer Services	



Solutions That Save.

FOR MORE INFORMATION

Contact any of our worldwide Perimeter Solutions Fire Safety offices or visit:

www.Perimeter-Solutions.com

UNITED STATES

1520 Brookfield Avenue
Green Bay, WI 54313

Tel: +1 (920) 593-9445

salesfoamusa@perimeter-solutions.com

EMEA

Polígono Industrial de Baiña, Parcela 23
33682 Baiña-Mieres (Asturias) – Spain

Tel: +34 985 24 29 45

salesfoamea@perimeter-solutions.com

ASIA PACIFIC

3 Charles Street
St Marys NSW 2760 – Australia

Tel: +61 2 9673 5300

salesfoamapac@perimeter-solutions.com

perimeter-solutions.com

NOTICE PERIMETER SOLUTIONS MAKES NO REPRESENTATIONS OR WARRANTIES AS TO THE COMPLETENESS OR ACCURACY OF THE INFORMATION INCLUDED HEREIN. THE INFORMATION CONTAINED HEREIN IS NOT INTENDED TO PROVIDE REGULATORY, LEGAL OR EXPERT ADVICE RELATING TO THE PRODUCTS, ITS APPLICATION OR USES. NOTHING CONTAINED HEREIN IS TO BE CONSTRUED AS A RECOMMENDATION TO USE ANY PRODUCT, PROCESS, EQUIPMENT OR FORMULATION IN CONFLICT WITH ANY INDUSTRIAL PROPERTY OR INTELLECTUAL PROPERTY RIGHTS, AND PERIMETER SOLUTIONS MAKES NO REPRESENTATION OR WARRANTY, EXPRESS OR IMPLIED, THAT THE USE THEREOF WILL NOT INFRINGE ON ANY INDUSTRIAL PROPERTY OR INTELLECTUAL PROPERTY RIGHTS. NO REPRESENTATIONS OR WARRANTIES, EITHER EXPRESSED OR IMPLIED, OF MERCHANTABILITY, FITNESS FOR A PARTICULAR PURPOSE OR OF ANY OTHER NATURE ARE MADE HEREUNDER WITH RESPECT TO THE INFORMATION CONTAINED HEREIN.

ARCTIC™ 3X6% FREEZE PROTECTED ATC™ FOAM CONCENTRATE

TYPICAL PHYSICAL PROPERTIES

AT 77 °F (25 °C)

Appearance: Clear light yellow liquid

Freezing Point: 0°F (-18°C)

(No quality loss after thawing)

Maximum Storage Temp: 120°F (49°C)

pH: 7.0 - 8.0

Refractive Index: 1.3640 - 1.3740

Specific Gravity: 1.020 - 1.035

Viscosity: 1600 - 2100 cP*

Sediments: None

*Brookfield Viscometer Spindle #4,

Speed 30 rpm

APPLICATION

ARCTIC 3X6 FP ATC foam concentrate can be applied to either Class B hydrocarbon or polar solvent fuel fires. The product is mixed 3 parts foam concentrate to 97 parts water for hydrocarbon fuels or 6 parts foam concentrates to 94 parts water for polar solvent fuels. The foam can be used to prevent re-ignition of a liquid spill and control hazardous vapors. Foam non-air aspirating, as well as air aspirating equipment, including standard fire sprinkler heads, can be used to obtain maximum results. ARCTIC 3X6 FP ATC foam is compatible with most powder (dry chemical) agents.

PERFORMANCE

Fire Performance

ARCTIC 3X6 FP ATC foam concentrate has been tested to and meets the fire performance test criteria of European Standard EN1568 Parts 3 & 4 (latest edition).

Foam Proportioning

ARCTIC 3X6 FP ATC foam concentrate can be proportioned at the proper foam solution percentage using most common proportioning devices such as:

- Eductors
- Inline balance pressure proportioners
- Ratio controllers
- Self-inducting nozzles



DESCRIPTION

ARCTIC™ 3X6 FP ATC foam concentrate from SOLBERG® is a synthetic alcohol-resistant freeze protected foam concentrate used to effectively extinguish Class B hydrocarbon fuel fires at 3% and polar solvent fuel fires at 6% solution. ARCTIC 3X6 FP ATC foam concentrate provides rapid extinguishment and excellent burn back characteristics and can be used with fresh, sea and brackish water.

STORAGE

The storage temperature range for ARCTIC 3x6 FP ATC foam concentrate is 0 °F to 120 °F (-18 °C to 49 °C).

When stored in original containers or in manufacturer recommended equipment and within the specified temperature range, the shelf life is 20 years.

COMPATIBILITY

ARCTIC 3X6 FP ATC foam concentrate should not be mixed with other foam concentrates. For questions about compatibility or mixing of foam concentrates, consult Perimeter Solutions Technical Services.

Materials of Construction Capability

ARCTIC 3X6 FP ATC foam concentrate is compatible with multiple materials of construction such as carbon steel, stainless steel, brass, polyethylene and PVC. Galvanized steel should not be used in direct contact with the foam concentrate. For questions about material compatibility, consult Perimeter Solutions Technical Services.

INSPECTION

ARCTIC 3X6 FP ATC foam concentrate or pre-mix solutions should be inspected annually per National Fire Protection Association (NFPA) Standards 11 and 25. A sample of the foam concentrate should be sent to the manufacturer for quality conditioning testing in accordance to NFPA 11.

ENVIRONMENTAL INFORMATION

ARCTIC 3X6 FP ATC foam concentrate complies with the United States Environmental Protection Agency (USEPA) Stewardship Program— 2015 Requirements.

ARCTIC™ 3X6% FREEZE PROTECTED ATC™ FOAM CONCENTRATE

CERTIFICATIONS

SOLBERG manufactured products are thoroughly inspected and undergo rigorous quality control tests. These evaluations analyze the foam's physical parameters and finished product's fire performance. A Certificate of Analysis (CoA) is issued with every batch. ARCTIC 3X6 FP ATC foam concentrate is Approved to European Standard EN1568 Parts 3 & 4..

ORDERING INFORMATION

ARCTIC 3x6% ATC foam concentrate is available in pails, drums, totes and bulk quantities.

Part No.	Description	Approximate Shipping Weight	Approximate Cube
20190	ARCTIC 3X6 FP ATC, 5 gallon (20 litre) pail	45 lb (21 kg)	1.25 ft ³ (0.04 m ³)
20191	ARCTIC 3X6 FP ATC, 55 gallon (200 litre) drum	495 lb (224 kg)	11.83 ft ³ (0.33 m ³)
20192	ARCTIC 3X6 FP ATC, 265 gallon (1000 litre) tote	2465 lb (1118 kg)	50.05 ft ³ (1.42 m ³)
20193	ARCTIC 3X6 FP ATC, bulk	Call Customer Services	



Solutions That Save.

FOR MORE INFORMATION

Contact any of our worldwide Perimeter Solutions Fire Safety offices or visit:

www.Perimeter-Solutions.com

UNITED STATES

10667 Jersey Blvd.
Rancho Cucamonga, CA 91730

Tel: +1 800 682 3626

Tel: +1 909 983 0772

salesfoamusa@perimeter-solutions.com

EMEA

Polígono de Baiña, Parcela 23
33682 Mieres (Asturias)

Spain

Tel: +34 985 24 29 45

salesfoamemea@perimeter-solutions.com

ASIA PACIFIC

3 Charles Street
St Marys NSW 2760 – Australia

Tel: +61 2 9673 5300

salesfoamapac@perimeter-solutions.com

perimeter-solutions.com

NOTICE PERIMETER SOLUTIONS MAKES NO REPRESENTATIONS OR WARRANTIES AS TO THE COMPLETENESS OR ACCURACY OF THE INFORMATION INCLUDED HEREIN. THE INFORMATION CONTAINED HEREIN IS NOT INTENDED TO PROVIDE REGULATORY, LEGAL OR EXPERT ADVICE RELATING TO THE PRODUCTS, ITS APPLICATION OR USES. NOTHING CONTAINED HEREIN IS TO BE CONSTRUED AS A RECOMMENDATION TO USE ANY PRODUCT, PROCESS, EQUIPMENT OR FORMULATION IN CONFLICT WITH ANY INDUSTRIAL PROPERTY OR INTELLECTUAL PROPERTY RIGHTS, AND PERIMETER SOLUTIONS MAKES NO REPRESENTATION OR WARRANTY, EXPRESS OR IMPLIED, THAT THE USE THEREOF WILL NOT INFRINGE ON ANY INDUSTRIAL PROPERTY OR INTELLECTUAL PROPERTY RIGHTS. NO REPRESENTATIONS OR WARRANTIES, EITHER EXPRESSED OR IMPLIED, OF MERCHANTABILITY, FITNESS FOR A PARTICULAR PURPOSE OR OF ANY OTHER NATURE ARE MADE HEREUNDER WITH RESPECT TO THE INFORMATION CONTAINED HEREIN.

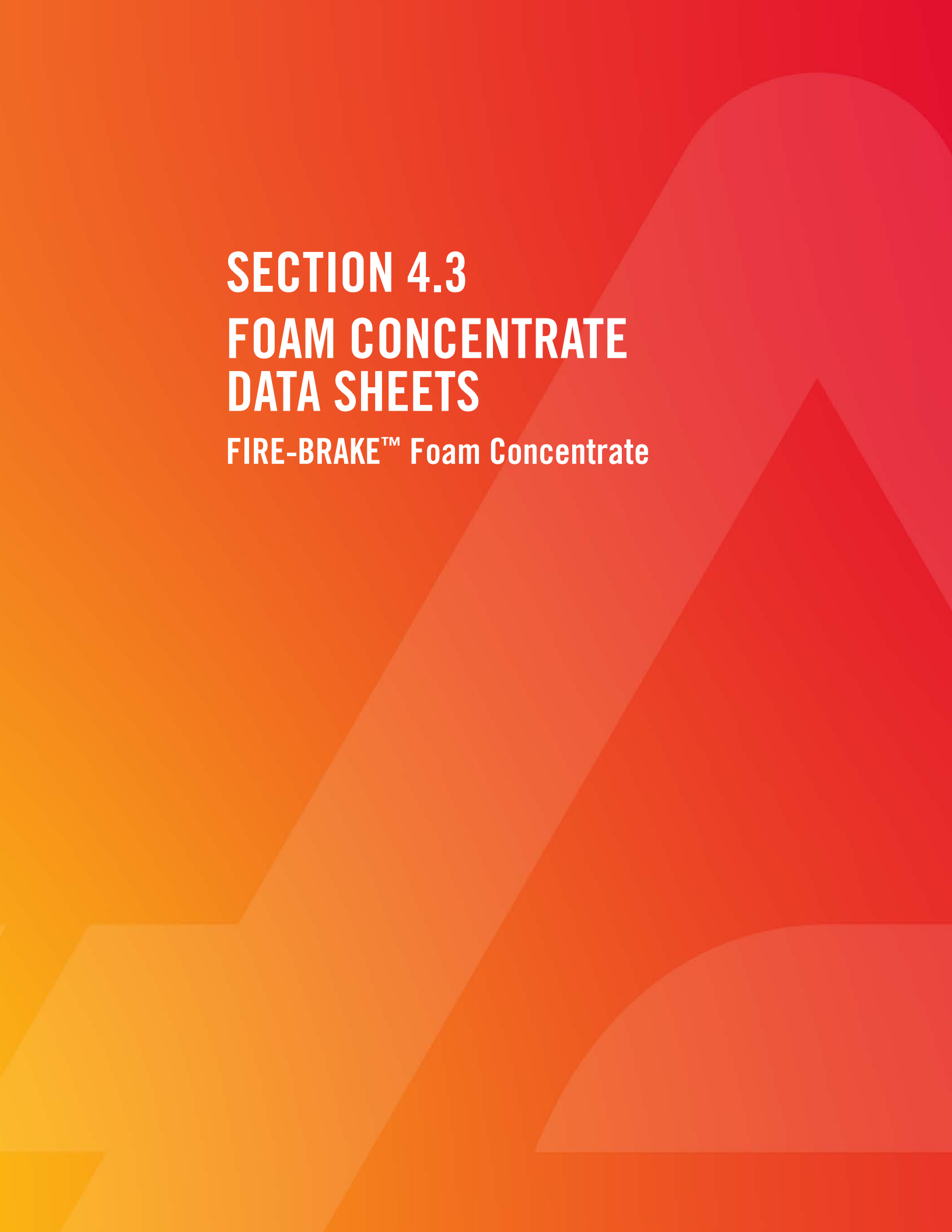

SECTION 4.3
FOAM CONCENTRATE
DATA SHEETS
FIRE-BRAKE™ Foam Concentrate

SOLBERG® FIRE-BRAKE™ FOAM CONCENTRATE



TYPICAL PHYSICAL PROPERTIES

AT 77 °F (25 °C)

Appearance: Clear, light yellow liquid

Freezing Point: 27°F (-3°C)

(No quality loss after thawing)

Maximum Storage Temp: 120°F (49°C)

pH: 7.0 - 8.5

Refractive Index: 1.3555 - 1.3595

Specific Gravity: 1.000 - 1.040

Viscosity: 3.0 - 5.0 cSt*

Sediments: < 0.05%

*Cannon - Fenske Viscometer



APPLICATION

SOLBERG FIRE-BRAKE Class A foam concentrate is designed and applied to Class A fires including wood, paper, coal, rubber, wildland and structure fires. SOLBERG FIRE-BRAKE Class A foam concentrate is compatible with conventional firefighting equipment such as non-air aspirating and air aspirating foam nozzles, Compressed Air Foam Systems (CAFS), rotary and fixed wing aircraft, low, medium and high expansion devices and has an admixture rate of 0.1% to 1.0% depending on use. FIRE-BRAKE should not be mixed with other foam concentrates.

APPLICATION RATES

Recommended application rates— SOLBERG FIRE-BRAKE Class A foam concentrate:

Mop-up: 0.25%

Suited for mop-up/overhaul, quickly penetrates Class A substrates

Initial Suppression: 0.5%

Penetrates tree canopies, draining to the forest floor layers and direct attack for structural firefighting

Fire-Brake: 0.75%

Good for initial suppression or forming a barrier

Protection: 1.0%

Adheres and insulates vertical surfaces

The minimum admixture rate on other Class A fuel types is 0.1%.

DESCRIPTION

SOLBERG® FIRE-BRAKE™ CLASS A FOAM CONCENTRATE from SOLBERG is a synthetic firefighting foam concentrate specially designed to be used for wildland, structural and other Class A fuel fires. SOLBERG FIRE-BRAKE Class A foam concentrate has the ability to reduce the surface tension of water, which substantially increases water's overall wetting capability. This creates a faster penetration and greater fire control when attacking combustible Class A fuels. SOLBERG FIRE-BRAKE Class A foam concentrate can be proportioned at the rate of 0.1 - 1% in fresh, sea and brackish water.

PERFORMANCE

Fire Performance

SOLBERG FIRE-BRAKE Class A foam concentrate has been tested to and meets the performance requirements of the U.S. Forest Service, Qualified Products List, Specification 5100-307b (as amended) for the applications as determined during the product evaluation and shown on the QPL, and meets the requirements of National Fire Protection Association (NFPA) 1150—Standard on Foam Chemicals for Fires in Class A Fuels (current edition).

Foam Proportioning

SOLBERG FIRE-BRAKE Class A foam concentrate can be proportioned using most proportioning equipment:

- Balanced pressure pump systems
- Bladder tank systems
- CAFS
- Eductors (with metering orifice)

STORAGE

The storage temperature range for SOLBERG FIRE-BRAKE Class A foam concentrate is 27°F to 120°F (-3°C to 49°C).

When stored in original containers or in manufacturer recommended equipment and within the specified temperature range, the shelf life is 10 years or more.

COMPATIBILITY

SOLBERG FIRE-BRAKE Class A foam concentrate should not be mixed with other foam concentrates. However, when the foam solution is applied to a fire the product

SOLBERG® FIRE-BRAKE™ CLASS A FOAM CONCENTRATE

can be mixed with other similar foam types. For questions about compatibility or mixing, consult Perimeter Solutions Technical Services.

Materials of Construction Capability

SOLBERG FIRE-BRAKE Class A foam concentrate is compatible with multiple materials of construction such as carbon steel, stainless steel, brass, polyethylene and PVC. Galvanized steel should not be used in direct contact with the foam concentrate. For questions about material compatibility, consult Perimeter Solutions Technical Services.

ENVIRONMENTAL INFORMATION

SOLBERG FIRE-BRAKE is biodegradable. When used and disposed of properly, this product does not adversely affect aquatic life. SOLBERG FIRE-BRAKE Class A foam concentrate does not contain any PFAS ingredients commonly found in fluorinated Class B foam concentrates. Perimeter Solutions foam manufacturing process is intentionally separated between fluorinated and non-fluorinated concentrate types, thus eliminating the potential for cross contamination or residual contamination.

CERTIFICATIONS

SOLBERG FIRE-BRAKE Class A foam concentrate is Qualified Products Listed (QPL) by the U.S. Forest Service in accordance with Forest Service Specification 5100-307b.

ORDERING INFORMATION

SOLBERG FIRE-BRAKE Class A foam concentrate is available in pails, drums, totes and bulk quantities.

Part No.	Description	Approximate Shipping Weight	Approximate Cube
20001	SOLBERG FIRE-BRAKE Class A foam concentrate, 5 gallon (20 litre) pail	45 lb (21 kg)	1.25 ft ³ (0.04 m ³)
20002	SOLBERG FIRE-BRAKE Class A foam concentrate, 55 gallon (200 litre) drum	495 lb (224 kg)	11.83 ft ³ (0.33 m ³)
20003	SOLBERG FIRE-BRAKE Class A foam concentrate, 265 gallon (1000 litre) tote	2465 lb (1118 kg)	50.05 ft ³ (1.42 m ³)
20004	SOLBERG FIRE-BRAKE Class A foam concentrate, bulk	Call Customer Services	



Solutions That Save.

FOR MORE INFORMATION

Contact any of our worldwide Perimeter Solutions Fire Safety offices or visit:

www.Perimeter-Solutions.com

UNITED STATES

10667 Jersey Blvd.
Rancho Cucamonga, CA 91730

Tel: +1 800 682 3626
Tel: +1 909 983 0772

salesfoamusa@perimeter-solutions.com

EMEA

Polígono de Baiña, Parcela 23
33682 Mieres (Asturias)
Spain

Tel: +34 985 24 29 45

salesfoamema@perimeter-solutions.com

ASIA PACIFIC

3 Charles Street
St Marys NSW 2760 – Australia

Tel: +61 2 9673 5300

salesfoamapac@perimeter-solutions.com

perimeter-solutions.com

NOTICE PERIMETER SOLUTIONS MAKES NO REPRESENTATIONS OR WARRANTIES AS TO THE COMPLETENESS OR ACCURACY OF THE INFORMATION INCLUDED HEREIN. THE INFORMATION CONTAINED HEREIN IS NOT INTENDED TO PROVIDE REGULATORY, LEGAL OR EXPERT ADVICE RELATING TO THE PRODUCTS, ITS APPLICATION OR USES. NOTHING CONTAINED HEREIN IS TO BE CONSTRUED AS A RECOMMENDATION TO USE ANY PRODUCT, PROCESS, EQUIPMENT OR FORMULATION IN CONFLICT WITH ANY INDUSTRIAL PROPERTY OR INTELLECTUAL PROPERTY RIGHTS, AND PERIMETER SOLUTIONS MAKES NO REPRESENTATION OR WARRANTY, EXPRESS OR IMPLIED, THAT THE USE THEREOF WILL NOT INFRINGE ON ANY INDUSTRIAL PROPERTY OR INTELLECTUAL PROPERTY RIGHTS. NO REPRESENTATIONS OR WARRANTIES, EITHER EXPRESSED OR IMPLIED, OF MERCHANTABILITY, FITNESS FOR A PARTICULAR PURPOSE OR OF ANY OTHER NATURE ARE MADE HEREUNDER WITH RESPECT TO THE INFORMATION CONTAINED HEREIN.

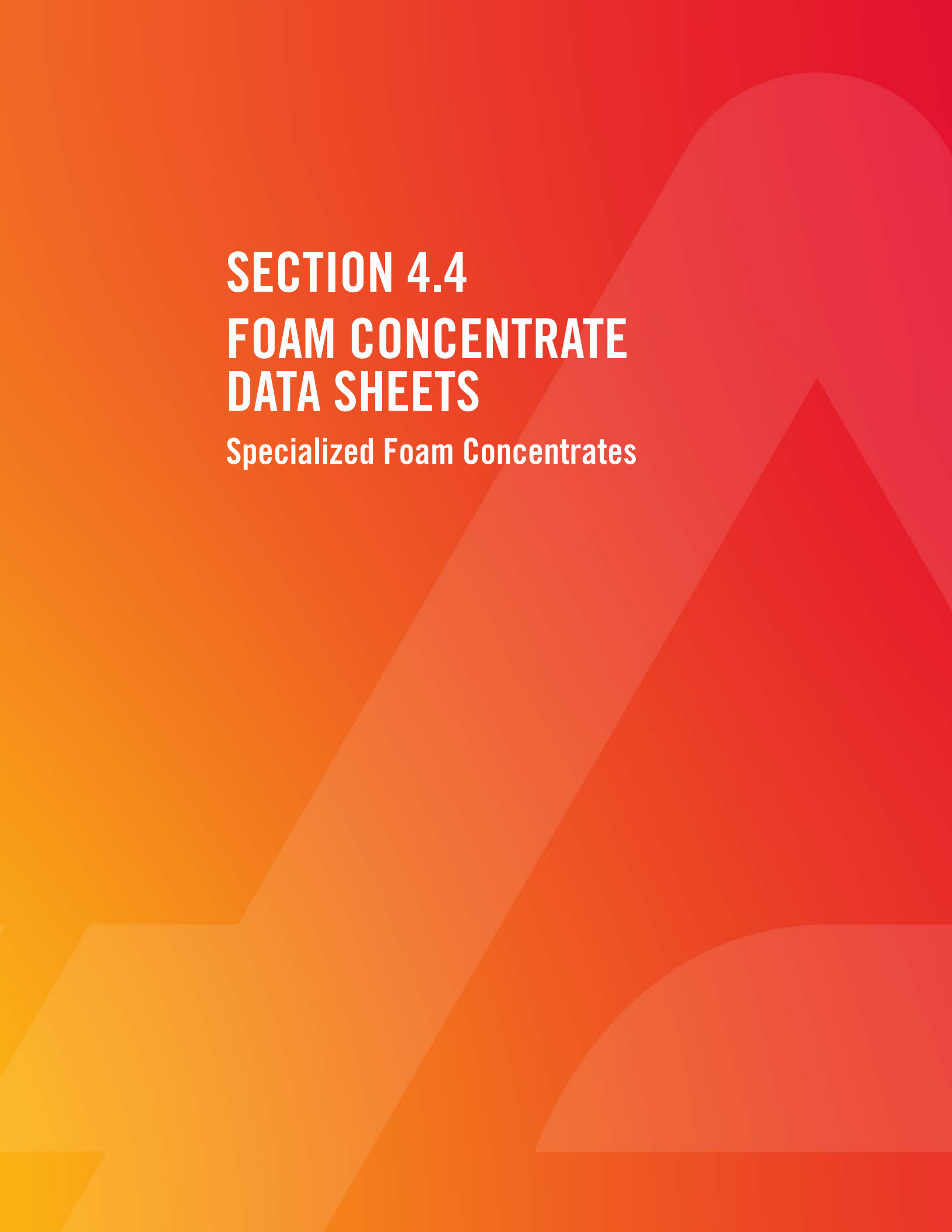
The background features a gradient from yellow-orange on the left to red on the right. Overlaid on this are several large, semi-transparent geometric shapes: a large circle in the upper right, a large triangle pointing downwards in the center-right, and a large semi-circle at the bottom right. The text is positioned in the upper left quadrant.

SECTION 4.4
FOAM CONCENTRATE
DATA SHEETS
Specialized Foam Concentrates

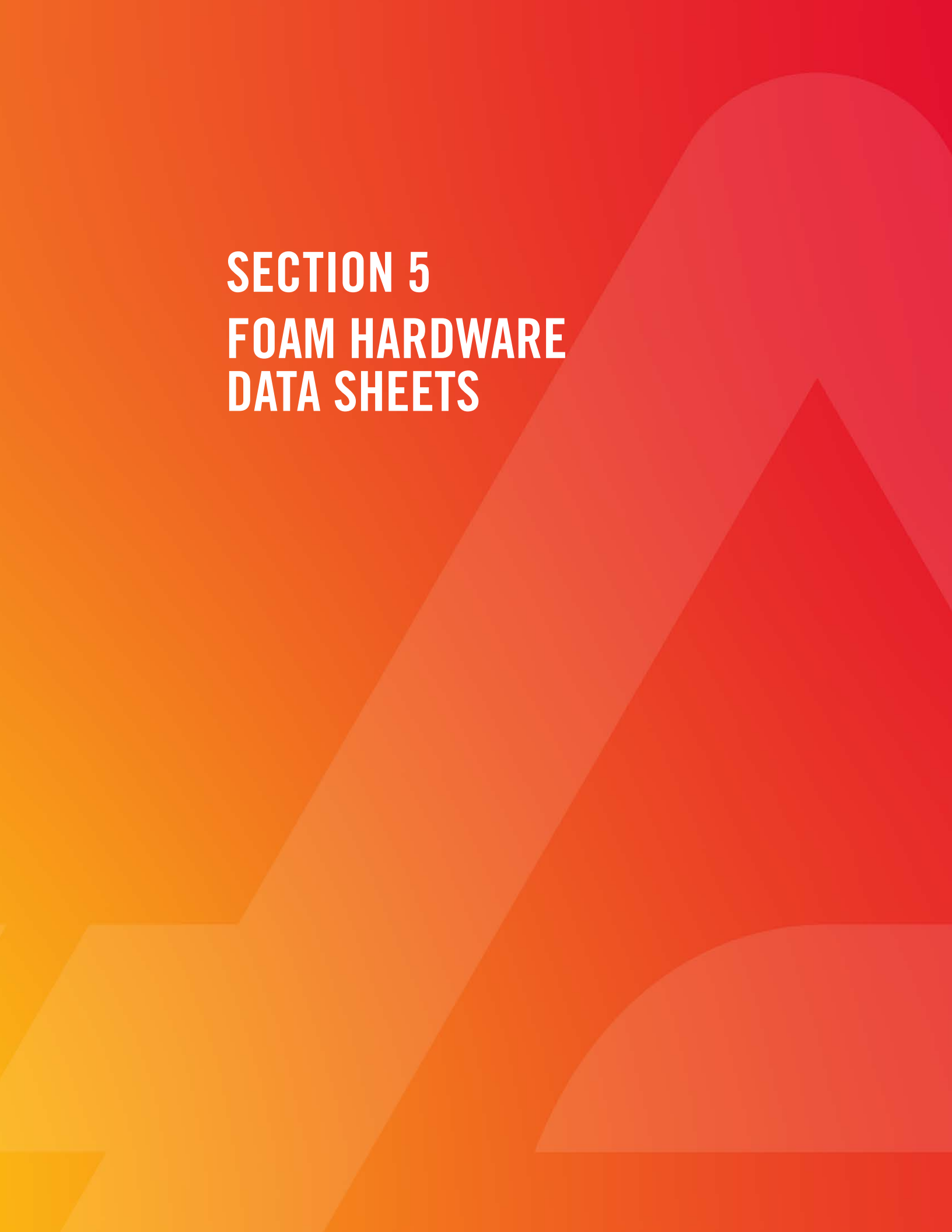
The background features a gradient from yellow-orange on the left to red on the right. Large, semi-transparent geometric shapes, including a large triangle and a circle, are layered over the gradient.

SECTION 5
FOAM HARDWARE
DATA SHEETS

Hardware

SOLBERG brand foam suppression systems hardware is engineered by a team with over 200 years of combined in-the-field fire protection experience. Our experts know the real-world challenges. And they know how to optimize the design of our proven products to fit the individual needs of each customer.

As a custom manufacturer, we tailor firefighting hardware to meet your particular specifications. You can count on us to work with you and deliver products that perform as needed, when you need them.

Our vast line of dependable, high performing SOLBERG products include the best solutions on the market.

Whether it's protecting high-risk assets or an emergency situation, SOLBERG hardware is exceeding the needs of fire safety professionals, risk managers, municipal firefighters and industrial fire suppression for industries worldwide, including:

- Aerospace
- Aviation
- Chemical
- Defense
- Energy
- Fire Services
- Marine
- Mining
- Oil & Gas
- Petrochemical
- Pharmaceuticals
- Pipelines
- Solvents & Coatings
- Utilities

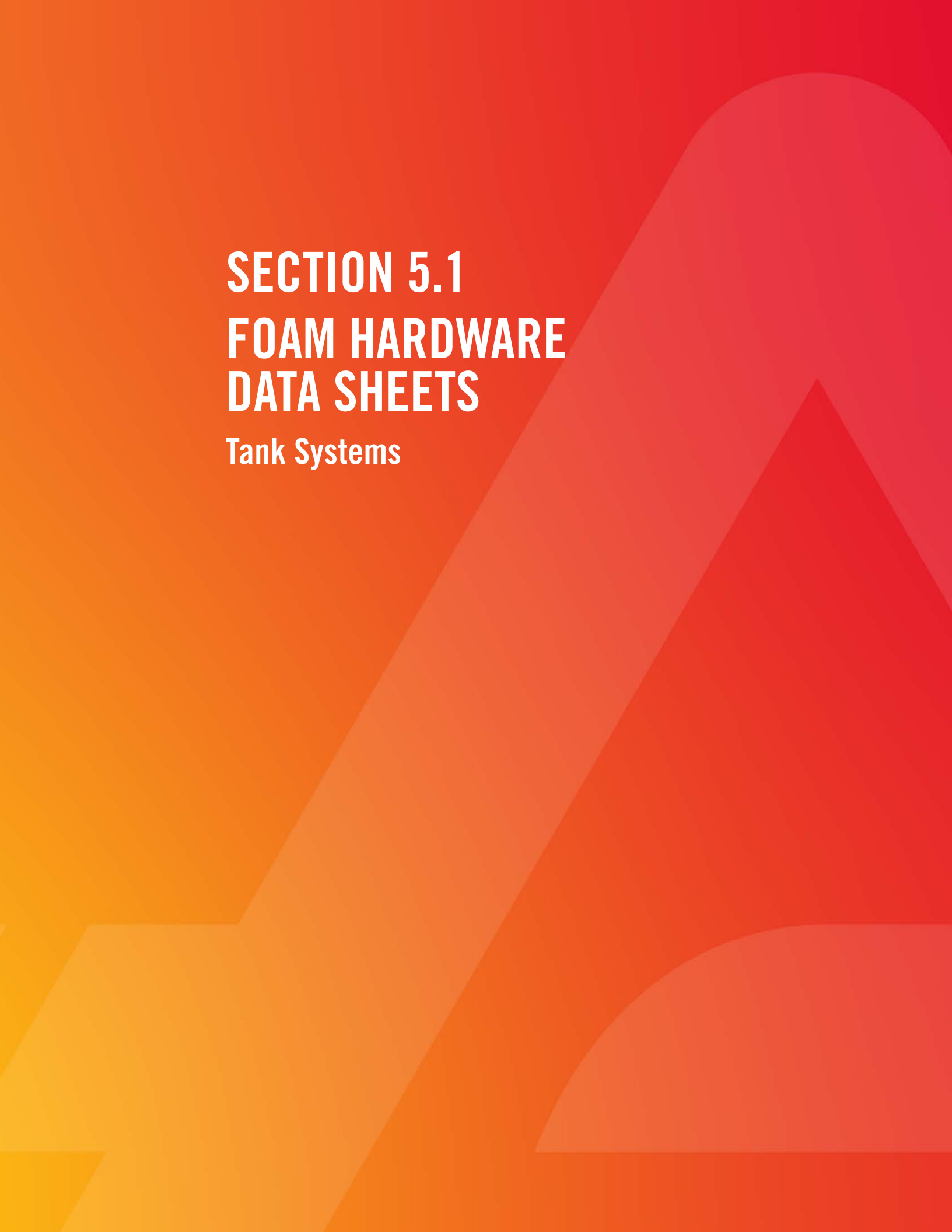
The background features a gradient from yellow-orange on the left to red on the right. Large, semi-transparent geometric shapes, including a large triangle and a circle, are overlaid on the background.

SECTION 5.1

FOAM HARDWARE

DATA SHEETS

Tank Systems

SOLBERG® ATMOSPHERIC FOAM STORAGE TANKS

FEATURES

- **Foam Concentrate or Pre-mix storage**
- **High density cross-linked polyethylene construction**
- **Level site gauge**
- **Translucent tank appearance**
- **Easy to fill while in operation**
- **Optional horizontal tank configuration (upon request)**

DESCRIPTION

SOLBERG® Atmospheric Foam Concentrate Storage Tanks* are manufactured of high-density, cross-linked polyethylene in a vertical configuration. Storage tank assemblies are equipped with a suction connection, return connection, drain/fill connection, and domed top. SOLBERG Atmospheric Foam Concentrate Storage Tanks are available in standard sizes or custom built to your specifications up to 10,000 gallons (37,854 litres).

APPLICATION

An atmospheric foam concentrate storage tank is a key component in a balanced pressure proportioning system. The storage tank is compatible with all SOLBERG foam concentrates (RE-HEALING™, ARCTIC™, FIRE-BRAKE™). Atmospheric storage tanks are normally used in conjunction with balanced pressure pump proportioning or inline balanced pressure proportioning skid type systems.

OPTIONS

- Flex connectors
- Horizontal tank configuration
- Low liquid level indicator float switch
- Pressure vacuum vent/drain valve
- Seismic restraints
- Carbon steel, stainless steel or fiberglass construction
- Custom built sizes



SOLBERG® ATMOSPHERIC FOAM STORAGE TANKS

DIMENSIONAL INFORMATION

MODEL	Nominal Tank Size gal (l)	Capacity gal (l)	APPROXIMATE DIMENSIONS Inches (Millimeters)				Suction Inlet Diameter	Return Inlet Diameter	Wall Thickness
			A	B	C	D			
23001	100 (379)	106 (401)	23.00 (584)	67.00 (1702)	8.00 (203)	11.50 (292)	2.00 (51) FNPT	1.50 (38) FNPT	0.25 (64)
23002	205 (776)	214 (810)	31.00 (787)	74.00 (1880)	8.00 (203)	15.50 (394)	2.00 (51) FNPT	1.50 (38) FNPT	0.25 (64)
23003	295 (1117)	319 (1208)	46.00 (1168)	53.00 (1346)	8.00 (203)	23.00 (584)	2.00 (51) FNPT	1.50 (38) FNPT	0.25 (64)
23004	475 (1798)	503 (1904)	48.00 (1219)	75.00 (1905)	8.00 (203)	24.00 (610)	2.00 (51) FNPT	1.50 (38) FNPT	0.25 (64)
23005	540 (2044)	565 (2139)	48.00 (1219)	82.00 (2083)	8.00 (203)	17.50 (445)	3.00 (76) Flange	2.00 (38) FNPT	0.25 (64)
23006	805 (3047)	834 (3157)	48.00 (1219)	119.00 (3023)	8.00 (203)	14.00 (356)	3.00 (76) Flange	2.00 (38) FNPT	0.25 (64)
23007	1000 (3785)	1164 (4406)	86.00 (2187)	53.00 (1346)	8.00 (203)	17.50 (445)	3.00 (76) Flange	2.00 (38) FNPT	0.31 (79)
23008	1150 (4353)	1229 (5652)	64.00 (1626)	98.00 (2489)	8.00 (203)	18.00 (457)	3.00 (76) Flange	3.00 (38) Flange	0.31 (79)
23009	1450 (5489)	1611 (6098)	86.00 (2184)	74.00 (1880)	8.00 (203)	16.00 (406)	3.00 (76) Flange	3.00 (38) Flange	0.31 (79)
23010	2250 (8517)	2492 (9433)	96.00 (2438)	93.00 (2362)	8.00 (203)	18.50 (470)	4.00 (102) Flange	3.00 (38) Flange	0.38 (97)
23011	2550 (9653)	2701 (10224)	85.00 (2159)	124.00 (3150)	8.00 (203)	19.00 (483)	4.00 (102) Flange	3.00 (38) Flange	0.38 (97)
23012	3000 (1356)	3173 (12011)	85.00 (2159)	140.00 (3556)	8.00 (203)	19.00 (483)	4.00 (102) Flange	3.00 (38) Flange	0.44 (112)
23013	3900 (14763)	4131 (15638)	94.00 (2388)	153.00 (3886)	1000 (254)	23.50 (597)	6.00 (152) Flange	4.00 (38) Flange	0.56 (142)
23014	5050 (19116)	5244 (19851)	94.00 (2388)	192.00 (4877)	1000 (254)	23.00 (584)	6.00 (152) Flange	4.00 (38) Flange	0.75 (191)

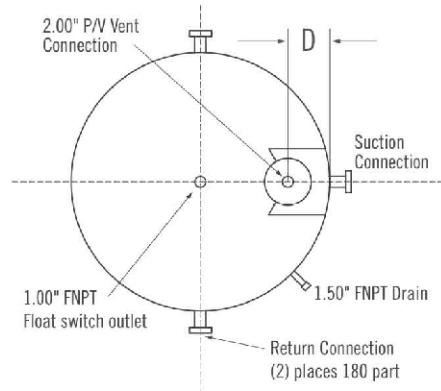
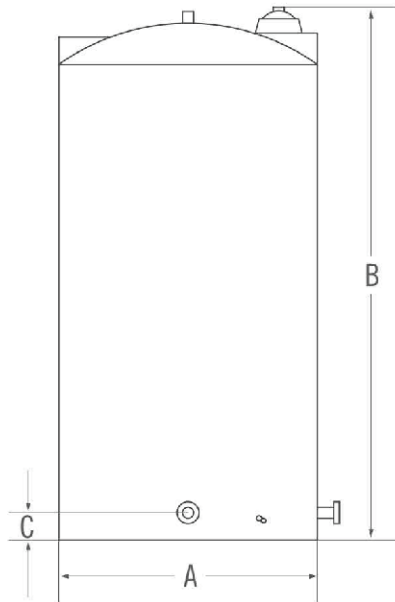

SOLBERG® ATMOSPHERIC FOAM STORAGE TANKS

ORDERING INFORMATION

ATMOSPHERIC FOAM STORAGE TANKS		APPROXIMATE SHIPPING WEIGHT	
PART NO.	DESCRIPTION	lb	kg
23001	SOLBERG Atmospheric Foam Tank - Poly, Vertical, 100 gallon (379 litre)	45	20
23002	SOLBERG Atmospheric Foam Tank - Poly, Vertical, 205 gallon (776 litre)	60	27
23003	SOLBERG Atmospheric Foam Tank- Poly, Vertical, 295 gallon (1117 litre)	75	34
23004	SOLBERG Atmospheric Foam Tank- Poly, Vertical, 475 gallon (1798 litre)	100	45
23005	SOLBERG Atmospheric Foam Tank- Poly, Vertical, 540 gallon (2044 litre)	120	54
23006	SOLBERG Atmospheric Foam Tank- Poly, Vertical, 805 gallon (3047 litre)	200	91
23007	SOLBERG Atmospheric Foam Tank- Poly, Vertical, 1000 gallon (3785 litre)	230	104
23008	SOLBERG Atmospheric Foam Tank - Poly, Vertical, 1150 gallon (4353 litre)	260	118
23009	SOLBERG Atmospheric Foam Tank- Poly, Vertical, 1450 gallon (5489 litre)	270	122
23010	SOLBERG Atmospheric Foam Tank - Poly, Vertical, 2250 gallon (8515 litre)	450	204
23011	SOLBERG Atmospheric Foam Tank - Poly, Vertical, 2550 gallon (9653 litre)	575	261
23012	SOLBERG Atmospheric Foam Tank- Poly, Vertical, 3000 gallon (11356 litre)	900	408
23013	SOLBERG Atmospheric Foam Tank- Poly, Vertical, 3900 gallon (14763 litre)	1000	454
23014	SOLBERG Atmospheric Foam Tank- Poly, Vertical, 5050 gallon (19116 litre)	1650	748

ACCESSORIES - POLY TANKS		APPROXIMATE SHIPPING WEIGHT	
PART NO.	DESCRIPTION	lb	kg
23200	Tank Trim Package, 2.0" (51 mm) Vacuum Vent, 1.5" (38 mm) Drain Valve	25	11
23201	Low Liquid Level Switch, (N.O.)	15	7
23202	Low Liquid Level Switch, (N.C.)	15	7
23203	Flex Connector, 1.5" (38 mm) Flanged	3	1
23204	Flex Connector, 2.0" (51 mm) Flanged	4	2
23205	Flex Connector, 3.0" (76 mm) Flanged	7	3
23206	Flex Connector, 4.0" (102 mm) Flanged	9	5
23207	Flex Connector, 6.0" (152 mm) Flanged	14	6
23208	Mineral Oil Concentrate Sealer, 5 gallon (20 litre) Pail	45	20



Solutions That Save.

FOR MORE INFORMATION

Contact any of our worldwide Perimeter Solutions Fire Safety offices or visit:

www.Perimeter-Solutions.com

UNITED STATES

10667 Jersey Blvd.
Rancho Cucamonga, CA 91730
Tel: +1 800 682 3626
Tel: +1 909 983 0772
salesfoamusa@perimeter-solutions.com

EMEA

Polígono de Baiña, Parcela 23
33682 Mieres (Asturias)
Spain
Tel: +34 985 24 29 45
salesfoamemea@perimeter-solutions.com

ASIA PACIFIC

3 Charles Street
St Marys NSW 2760 – Australia
Tel: +61 2 9673 5300
salesfoamapac@perimeter-solutions.com

perimeter-solutions.com

NOTICE PERIMETER SOLUTIONS MAKES NO REPRESENTATIONS OR WARRANTIES AS TO THE COMPLETENESS OR ACCURACY OF THE INFORMATION INCLUDED HEREIN. THE INFORMATION CONTAINED HEREIN IS NOT INTENDED TO PROVIDE REGULATORY, LEGAL OR EXPERT ADVICE RELATING TO THE PRODUCTS, ITS APPLICATION OR USES. NOTHING CONTAINED HEREIN IS TO BE CONSTRUED AS A RECOMMENDATION TO USE ANY PRODUCT, PROCESS, EQUIPMENT OR FORMULATION IN CONFLICT WITH ANY INDUSTRIAL PROPERTY OR INTELLECTUAL PROPERTY RIGHTS, AND PERIMETER SOLUTIONS MAKES NO REPRESENTATION OR WARRANTY, EXPRESS OR IMPLIED, THAT THE USE THEREOF WILL NOT INFRINGE ON ANY INDUSTRIAL PROPERTY OR INTELLECTUAL PROPERTY RIGHTS. NO REPRESENTATIONS OR WARRANTIES, EITHER EXPRESSED OR IMPLIED, OF MERCHANTABILITY, FITNESS FOR A PARTICULAR PURPOSE OR OF ANY OTHER NATURE ARE MADE HEREUNDER WITH RESPECT TO THE INFORMATION CONTAINED HEREIN.

*THIS PRODUCT IS SOLD UNDER THE SOLBERG® TRADE NAME. CERTIFICATIONS WILL VARY DEPENDING UPON TRADE NAME.

SOLBERG® BLADDER TANKS – HORIZONTAL & VERTICAL



FEATURES

- **UL Listed with SOLBERG foam concentrates**
- **FM Approved with SOLBERG® RE-HEALING™ RF3, 3% and ARCTIC 3x3% ATC™ Foam Concentrates**
- **Accurate concentrate proportioning permits operation over a wide range of flow rates**
- **Design simplicity minimizes system failure due to mechanical issues**
- **Ease of operation, requires no outside source of power**
- **Ease of retrofit into existing water based extinguishing systems**
- **Fully automatic or manual systems available**
- **Minimized installation costs compared to other proportioning methods**
- **Uses existing water pressure for delivery of foam solution to the discharge devices**

DESCRIPTION

SOLBERG® Bladder Tanks are the main component in a balanced pressure proportioning bladder tank system, which require no outside power source other than an adequate water supply.

The SOLBERG Bladder Tank is a carbon steel pressure vessel with a nylon reinforced neoprene rubber bladder that stores the foam concentrate. During operation the foam concentrate is discharged from the tank by the water supply, collapsing the bladder around the perforated center tube until the concentrate is depleted. SOLBERG Bladder Tanks are available in both vertical and horizontal versions in multiple sizes.

APPLICATION

SOLBERG Bladder Tanks can be used in multiple high-hazard, high-risk, applications including aircraft hangars, foam-water sprinkler systems, helipads, and truck loading racks.

SPECIFICATIONS

Vertical and horizontal bladder tanks are manufactured in compliance with ASME Code Section VIII Division 1 with a designed working pressure of 175 psi (12 bar) and tested to 263 psi (18 bar) — 1.5 times the working pressure. The tank is constructed



out of SA 516 Grade 70 carbon steel with a nylon reinforced neoprene rubber bladder. It has a perforated center tube, and a .37" (9 mm) water channel between the water inlet and water drain valve, which creates a water path between the bladder and tank shell. Openings that are greater than 1.0" (25 mm) will be divided to prevent bladder damage.

Vertical bladder tank construction shall be mounted on a full skirt with four tabs drilled for anchoring.

Horizontal bladder tank construction shall be supported by two saddles with four mounting holes per saddle. Refer to dimensional drawings for mounting hole spacing in this data sheet.

BLADDER TANKS – HORIZONTAL & VERTICAL

All bladder tanks are furnished with lifting lugs, an ASME welded nameplate, and 1.0" (25 mm) bronze trim locking handle valves, to be in accordance with NFPA Standard 11, and the Solberg Operation and Maintenance Manual.

The exterior of all bladder tanks will be prepared and finished with Solberg standard blue or red enamel finish.

OPTIONS

- 100% X-Ray design
- Carbon or stainless steel construction
- Custom tank size and dimensions
- Epoxy or coal tar inner liner

- Inspection service
- National board registration
- Pressure relief valve*
- Seismic calculations
- Sight gage assembly
- Start-up and commission service

CERTIFICATIONS

American Society of Mechanical Engineers (ASME), Underwriters Laboratories, Inc. (UL) Listed – Standard 162, FM Approved per Approval Standard 5130.

*Not Part of FM Approval

DIMENSIONAL INFORMATION - HORIZONTAL

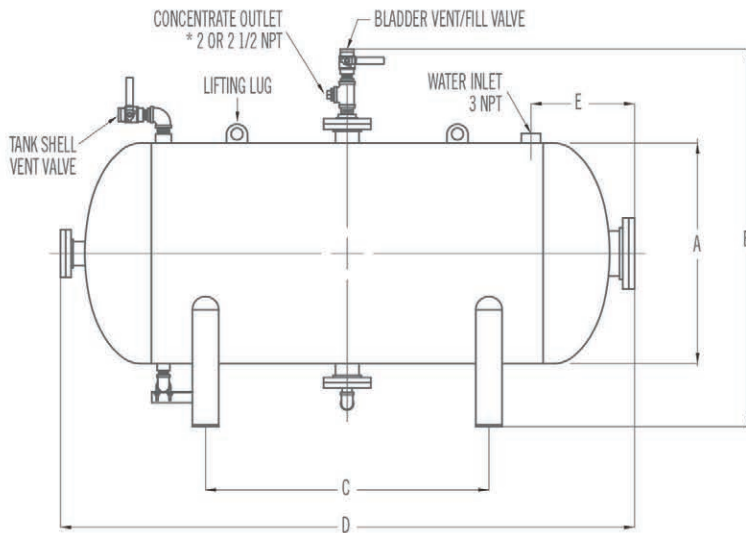

* 2 NPT ON TANKS 200 GALLONS OR LESS
 * 2 1/2 NPT ON TANKS OVER 200 GALLONS

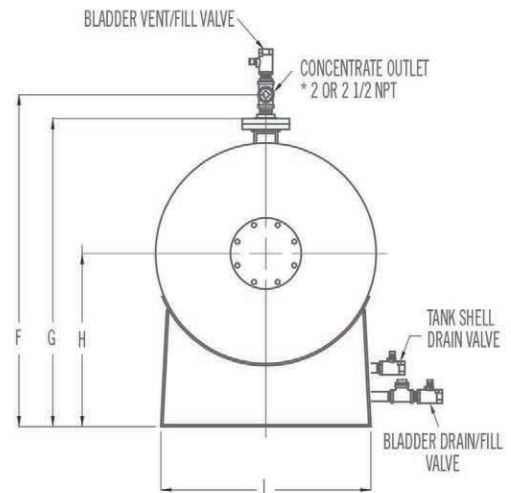

BLADDER TANKS – HORIZONTAL & VERTICAL

DIMENSIONAL INFORMATION - HORIZONTAL

APPROXIMATE DIMENSIONS Inches (Millimeters)

CAPACITY gallon (litre)	A	B	C	D	E	F	G
50 (189)	20 (508)	47 (1194)	14 (356)	55.5 (1410)	19.1875 (488)	41.5 (1055)	36 (915)
100 (379)	24 (610)	51 (1296)	22 (559)	72 (1829)	20.1875 (513)	45.5 (1156)	40 (1016)
150 (568)	30 (762)	57 (1448)	36 (915)	71 (1804)	21.6875 (551)	51.5 (1309)	46 (1169)
200 (757)	30 (762)	57 (1448)	34 (864)	89 (2261)	21.6875 (551)	51.5 (1309)	46 (1169)
300 (1136)	36 (915)	64 (1626)	36 (915)	93 (2363)	23.1875 (589)	58 (1474)	52 (1321)
400 (1514)	42 (1067)	70 (1778)	50 (1270)	93 (2363)	24.6875 (628)	64 (1626)	58 (1474)
500 (1893)	42 (1067)	70 (1778)	48 (1220)	112 (2845)	24.6875 (628)	64 (1626)	58 (1474)
600 (2271)	42 (1067)	70 (1778)	60 (1524)	131 (3328)	24.6875 (628)	64 (1626)	58 (1474)
700 (2650)	48 (1220)	80 (2032)	50 (1270)	119 (3023)	26.1875 (666)	74 (1880)	68 (1728)
800 (3028)	48 (1220)	80 (2032)	60 (1524)	134 (3404)	26.1875 (666)	74 (1880)	68 (1728)
900 (3407)	48 (1220)	80 (2032)	70 (1778)	148 (3760)	26.1875 (666)	74 (1880)	68 (1728)
1000 (3785)	48 (1220)	80 (2032)	94 (2388)	163 (4141)	26.1875 (666)	74 (1880)	68 (1728)
1100 (4164)	48 (1220)	80 (2032)	100 (2540)	177 (4496)	26.1875 (666)	74 (1880)	68 (1728)
1200 (4542)	60 (1524)	92 (2337)	58 (1474)	131 (3328)	29.25 (743)	86 (2185)	80 (2032)
1300 (4921)	60 (1524)	92 (2337)	60 (1524)	141 (3582)	29.25 (743)	86 (2185)	80 (2032)
1400 (5299)	60 (1524)	92 (2337)	76 (1931)	151 (3836)	29.25 (743)	86 (2185)	80 (2032)
1500 (5678)	60 (1524)	92 (2337)	80 (2032)	159 (4039)	29.25 (743)	86 (2185)	80 (2032)
1600 (6056)	72 (1829)	102 (2591)	44 (1118)	125 (3175)	32.25 (820)	96 (2439)	90 (2286)
1800 (6813)	72 (1829)	102 (2591)	56 (1423)	138 (3506)	32.25 (820)	96 (2439)	90 (2286)
1900 (7192)	72 (1829)	102 (2591)	60 (1524)	144 (3658)	32.25 (820)	96 (2439)	90 (2286)
2000 (7570)	72 (1829)	102 (2591)	70 (1778)	151 (3836)	32.25 (820)	96 (2439)	90 (2286)
2200 (8327)	72 (1829)	102 (2591)	80 (2032)	164 (4166)	32.25 (820)	96 (2439)	90 (2286)
2400 (9084)	72 (1829)	102 (2591)	80 (2032)	177 (4496)	32.25 (820)	96 (2439)	90 (2286)
2600 (9841)	72 (1829)	102 (2591)	100 (2540)	189 (4801)	32.25 (820)	96 (2439)	90 (2286)
2800 (10598)	72 (1829)	102 (2591)	100 (2540)	202 (5131)	32.25 (820)	96 (2439)	90 (2286)
3000 (11355)	72 (1829)	102 (2591)	120 (3048)	215 (5461)	32.25 (820)	96 (2439)	90 (2286)
3200 (12112)	72 (1829)	102 (2591)	120 (3048)	228 (5792)	32.25 (820)	96 (2439)	90 (2286)
3300 (12491)	72 (1829)	102 (2591)	120 (3048)	234 (5944)	32.25 (820)	96 (2439)	90 (2286)

BLADDER TANKS – HORIZONTAL & VERTICAL

DIMENSIONAL INFORMATION - HORIZONTAL

APPROXIMATE DIMENSIONS Inches (Millimeters)

CAPACITY gallon (litre)	H	I	J	K	L	M
50 (189)	22 (559)	20 (508)	0.875 (23)	7 (178)	3 (77)	0.5625 (15)
100 (379)	24 (610)	24 (610)	0.875 (23)	9 (229)	3 (77)	0.5625 (15)
150 (568)	27 (686)	30 (762)	1.125 (29)	11 (280)	4 (102)	0.5625 (15)
200 (757)	27 (686)	30 (762)	1.125 (29)	11 (280)	4 (102)	0.5625 (15)
300 (1136)	30 (762)	34 (864)	1.125 (29)	13 (331)	4 (102)	0.5625 (15)
400 (1514)	33 (839)	40 (1016)	1.375 (35)	15 (381)	5 (127)	0.6875 (18)
500 (1893)	33 (839)	40 (1016)	1.375 (35)	15 (381)	5 (127)	0.6875 (18)
600 (2271)	33 (839)	40 (1016)	1.375 (35)	15 (381)	5 (127)	0.6875 (18)
700 (2650)	40 (1016)	44 (1118)	1.375 (35)	17 (432)	5 (127)	0.6875 (18)
800 (3028)	40 (1016)	44 (1118)	1.375 (35)	17 (432)	5 (127)	0.6875 (18)
900 (3407)	40 (1016)	44 (1118)	1.375 (35)	17 (432)	5 (127)	0.6875 (18)
1000 (3785)	40 (1016)	44 (1118)	1.375 (35)	17 (432)	5 (127)	0.6875 (18)
1100 (4164)	40 (1016)	44 (1118)	1.375 (35)	17 (432)	5 (127)	0.6875 (18)
1200 (4542)	46 (1169)	54 (1372)	1.75 (45)	22 (559)	6 (153)	0.6875 (18)
1300 (4921)	46 (1169)	54 (1372)	1.75 (45)	22 (559)	6 (153)	0.6875 (18)
1400 (5299)	46 (1169)	54 (1372)	1.75 (45)	22 (559)	6 (153)	0.6875 (18)
1500 (5678)	46 (1169)	54 (1372)	1.75 (45)	22 (559)	6 (153)	0.6875 (18)
1600 (6056)	50 (1270)	64 (1626)	2.75 (70)	28 (712)	8 (204)	1.0625 (27)
1800 (6813)	50 (1270)	64 (1626)	2.75 (70)	28 (712)	8 (204)	1.0625 (27)
1900 (7192)	50 (1270)	64 (1626)	2.75 (70)	28 (712)	8 (204)	1.0625 (27)
2000 (7570)	50 (1270)	64 (1626)	2.75 (70)	28 (712)	8 (204)	1.0625 (27)
2200 (8327)	50 (1270)	64 (1626)	2.75 (70)	28 (712)	8 (204)	1.0625 (27)
2400 (9084)	50 (1270)	64 (1626)	2.75 (70)	28 (712)	8 (204)	1.0625 (27)
2600 (9841)	50 (1270)	64 (1626)	2.75 (70)	28 (712)	8 (204)	1.0625 (27)
2800 (10598)	50 (1270)	64 (1626)	2.75 (70)	28 (712)	8 (204)	1.0625 (27)
3000 (11355)	50 (1270)	64 (1626)	2.75 (70)	28 (712)	8 (204)	1.0625 (27)
3200 (12112)	50 (1270)	64 (1626)	2.75 (70)	28 (712)	8 (204)	1.0625 (27)
3300 (12491)	50 (1270)	64 (1626)	2.75 (70)	28 (712)	8 (204)	1.0625 (27)

BLADDER TANKS – HORIZONTAL & VERTICAL

DIMENSIONAL INFORMATION - VERTICAL

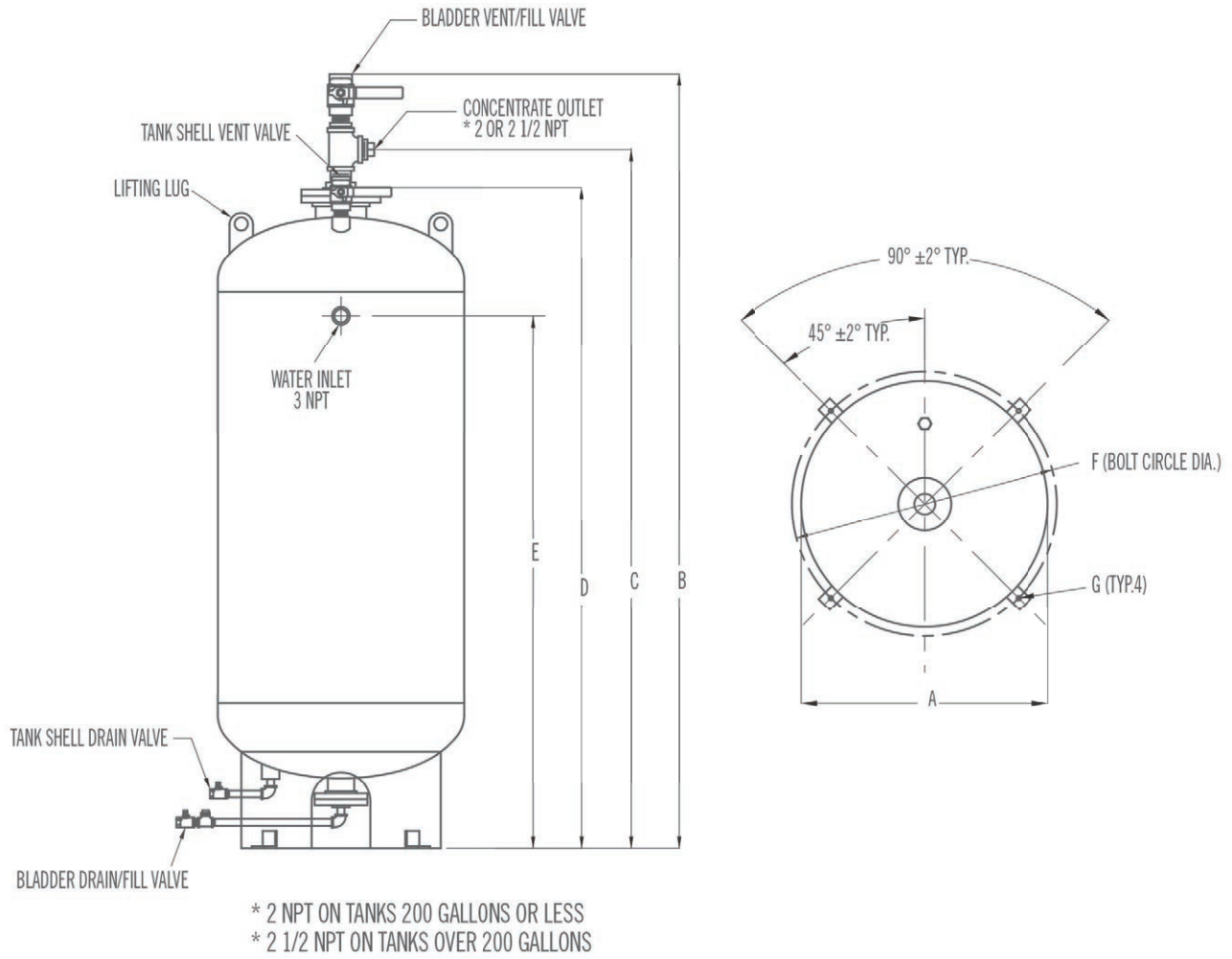

BLADDER TANKS – HORIZONTAL & VERTICAL

DIMENSIONAL INFORMATION - VERTICAL

APPROXIMATE DIMENSIONS Inches (Millimeters)

CAPACITY gallon (litre)	A	B	C	D	E	F	G
36 (136)	24 (610)	52 (1321)	46.5 (1182)	41 (1042)	27 (686)	26.75 (680)	0.5625 (15)
50 (189)	24 (610)	60 (1524)	54.5 (1385)	49 (1245)	35 (889)	26.75 (680)	0.5625 (15)
100 (379)	24 (610)	89 (2261)	83.5 (2121)	78 (1982)	64 (1626)	26.75 (680)	0.5625 (15)
150 (568)	30 (762)	88 (2236)	82.5 (2096)	77 (1956)	59 (1499)	27.75 (705)	0.5625 (15)
200 (757)	30 (762)	107 (2718)	101 (2566)	95 (2413)	77 (1956)	27.75 (705)	0.5625 (15)
300 (1136)	36 (915)	111 (2820)	105 (2667)	99 (2515)	80 (2032)	32.75 (832)	0.5625 (15)
400 (1514)	42 (1067)	105 (2667)	99 (2515)	82 (2083)	70 (1778)	41.5 (1055)	0.6875 (18)
500 (1893)	42 (1067)	130 (3302)	124 (3150)	96 (2439)	95 (2413)	41.5 (1055)	0.6875 (18)
600 (2271)	48 (1220)	123 (3125)	117 (2972)	111 (2820)	88 (2236)	41.5 (1055)	0.6875 (18)
700 (2650)	48 (1220)	137 (3480)	131 (3328)	125 (3175)	102 (2591)	41.5 (1055)	0.6875 (18)
800 (3028)	48 (1220)	155 (3937)	149 (3785)	143 (3633)	117 (2972)	51.5 (1309)	0.6875 (18)
900 (3407)	60 (1524)	125 (3175)	119 (3023)	113 (2871)	87 (2210)	51.5 (1309)	0.6875 (18)
1000 (3785)	60 (1524)	135 (3429)	129 (3277)	123 (3125)	97 (2464)	51.5 (1309)	0.8125 (21)
1100 (4164)	60 (1524)	144 (3658)	138 (3506)	132 (3353)	106 (2693)	51.5 (1309)	0.8125 (21)
1200 (4542)	60 (1524)	153 (3887)	147 (3734)	141 (3582)	115 (2921)	51.5 (1309)	0.8125 (21)
1300 (4921)	60 (1524)	163 (4141)	157 (3988)	151 (3836)	125 (3175)	51.5 (1309)	0.8125 (21)
1400 (5299)	60 (1524)	172 (4369)	166 (4217)	160 (4064)	134 (3404)	51.5 (1309)	0.8125 (21)
1500 (5678)	60 (1524)	181 (4598)	175 (4445)	169 (4293)	143 (3633)	51.5 (1309)	0.8125 (21)
1600 (6056)	72 (1829)	147 (3734)	141 (3582)	135 (3429)	106 (2693)	57.5 (1461)	0.8125 (21)
1700 (6435)	72 (1829)	153 (3887)	147 (3734)	141 (3582)	112 (2845)	57.5 (1461)	0.8125 (21)

BLADDER TANKS – HORIZONTAL & VERTICAL

ORDERING INFORMATION

HORIZONTAL BLADDER TANKS		APPROXIMATE SHIPPING WEIGHT	
		lb	kg
PART NO.	DESCRIPTION		
22001	Bladder Tank - Horizontal, 50 gallon (189 litre), Blue Enamel Finish	360	164
22002	Bladder Tank - Horizontal, 100 gallon (379 litre), Blue Enamel Finish	651	296
22003	Bladder Tank - Horizontal, 150 gallon (568 litre), Blue Enamel Finish	940	427
22004	Bladder Tank - Horizontal, 200 gallon (757 litre), Blue Enamel Finish	1137	516
22005	Bladder Tank - Horizontal, 300 gallon (1136 litre), Blue Enamel Finish	1554	705
22006	Bladder Tank - Horizontal, 400 gallon (1514 litre), Blue Enamel Finish	1870	849
22007	Bladder Tank - Horizontal, 500 gallon (1893 litre), Blue Enamel Finish	2130	967
22008	Bladder Tank - Horizontal, 600 gallon (2271 litre), Blue Enamel Finish	2237	1015
22009	Bladder Tank - Horizontal, 700 gallon (2650 litre), Blue Enamel Finish	2644	1200
22010	Bladder Tank - Horizontal, 800 gallon (3028 litre), Blue Enamel Finish	3298	1496
22011	Bladder Tank - Horizontal, 900 gallon (3407 litre), Blue Enamel Finish	3655	1658
22012	Bladder Tank - Horizontal, 1000 gallon (3785 litre), Blue Enamel Finish	3872	1757
22013	Bladder Tank - Horizontal, 1100 gallon (4164 litre), Blue Enamel Finish	4256	1931
22014	Bladder Tank - Horizontal, 1200 gallon (4542 litre), Blue Enamel Finish	4323	1961
22015	Bladder Tank - Horizontal, 1300 gallon (4921 litre), Blue Enamel Finish	4626	2099
22016	Bladder Tank - Horizontal, 1400 gallon (5300 litre), Blue Enamel Finish	4913	2229
22017	Bladder Tank - Horizontal, 1500 gallon (5678 litre), Blue Enamel Finish	5294	2402
22018	Bladder Tank - Horizontal, 1600 gallon (6057 litre), Blue Enamel Finish	4691	2128
22019	Bladder Tank - Horizontal, 1800 gallon (6814 litre), Blue Enamel Finish	5054	2293
22020	Bladder Tank - Horizontal, 1900 gallon (7192 litre), Blue Enamel Finish	5279	2395
22021	Bladder Tank - Horizontal, 2000 gallon (7571 litre), Blue Enamel Finish	5504	2497
22022	Bladder Tank - Horizontal, 2200 gallon (8328 litre), Blue Enamel Finish	5887	2671
22023	Bladder Tank - Horizontal, 2400 gallon (9085 litre), Blue Enamel Finish	6299	2858
22024	Bladder Tank - Horizontal, 2600 gallon (9842 litre), Blue Enamel Finish	6699	3039
22025	Bladder Tank - Horizontal, 2800 gallon (10599 litre), Blue Enamel Finish	7078	3211
22026	Bladder Tank - Horizontal, 3000 gallon (11356 litre), Blue Enamel Finish	7478	3392
22027	Bladder Tank - Horizontal, 3200 gallon (12113 litre), Blue Enamel Finish	7880	3575
22028	Bladder Tank - Horizontal, 3300 gallon (12492 litre), Blue Enamel Finish	8100	3675

BLADDER TANKS – HORIZONTAL & VERTICAL

ORDERING INFORMATION

PART NO.	DESCRIPTION	APPROXIMATE SHIPPING WEIGHT	
		lb	kg
22400	Bladder Tank - Vertical, 36 Gallon (136 litre), Blue Enamel Finish	230	105
22401	Bladder Tank - Vertical, 50 Gallon (189 litre), Blue Enamel Finish	235	107
22402	Bladder Tank - Vertical, 100 Gallon (379 litre), Blue Enamel Finish	385	175
22403	Bladder Tank - Vertical, 150 Gallon (568 litre), Blue Enamel Finish	540	245
22404	Bladder Tank - Vertical, 200 Gallon (757 litre), Blue Enamel Finish	665	302
22405	Bladder Tank - Vertical, 300 Gallon (1136 litre), Blue Enamel Finish	1005	456
22406	Bladder Tank - Vertical, 400 Gallon (1514 litre), Blue Enamel Finish	1405	638
22407	Bladder Tank - Vertical, 500 Gallon (1893 litre), Blue Enamel Finish	1455	660
22408	Bladder Tank - Vertical, 600 Gallon (2271 litre), Blue Enamel Finish	1550	704
22409	Bladder Tank - Vertical, 700 Gallon (2650 litre), Blue Enamel Finish	1680	763
22410	Bladder Tank - Vertical, 800 Gallon (3028 litre), Blue Enamel Finish	1880	853
22411	Bladder Tank - Vertical, 900 Gallon (3407 litre), Blue Enamel Finish	2200	998
22412	Bladder Tank - Vertical, 1000 Gallon (3785 litre), Blue Enamel Finish	2600	1180
22413	Bladder Tank - Vertical, 1100 Gallon (4164 litre), Blue Enamel Finish	2960	1343
22414	Bladder Tank - Vertical, 1200 Gallon (4542 litre), Blue Enamel Finish	3075	1395
22415	Bladder Tank - Vertical, 1300 Gallon (4921 litre), Blue Enamel Finish	3175	1441
22416	Bladder Tank - Vertical, 1400 Gallon (5300 litre), Blue Enamel Finish	3310	1502
22417	Bladder Tank - Vertical, 1500 Gallon (5678 litre), Blue Enamel Finish	3350	1520
22418	Bladder Tank - Vertical, 1600 Gallon (6057 litre), Blue Enamel Finish	3500	1588
22419	Bladder Tank - Vertical, 1700 Gallon (6435 litre), Blue Enamel Finish	3625	1645



Solutions That Save.

FOR MORE INFORMATION

Contact any of our worldwide Perimeter Solutions Fire Safety offices or visit:

www.Perimeter-Solutions.com

UNITED STATES

10667 Jersey Blvd.
Rancho Cucamonga, CA 91730
Tel: +1 800 682 3626
Tel: +1 909 983 0772
salesfoamusa@perimeter-solutions.com

EMEA

Polígono Industrial de Baiña, Parcela 23
33682 Baiña-Mieres (Asturias) – Spain
Tel: +34 985 24 29 45
salesfoamea@perimeter-solutions.com

ASIA PACIFIC

3 Charles Street
St Marys NSW 2760 – Australia
Tel: +61 2 9673 5300
salesfoamapac@perimeter-solutions.com

perimeter-solutions.com

NOTICE PERIMETER SOLUTIONS MAKES NO REPRESENTATIONS OR WARRANTIES AS TO THE COMPLETENESS OR ACCURACY OF THE INFORMATION INCLUDED HEREIN. THE INFORMATION CONTAINED HEREIN IS NOT INTENDED TO PROVIDE REGULATORY, LEGAL OR EXPERT ADVICE RELATING TO THE PRODUCTS, ITS APPLICATION OR USES. NOTHING CONTAINED HEREIN IS TO BE CONSTRUED AS A RECOMMENDATION TO USE ANY PRODUCT, PROCESS, EQUIPMENT OR FORMULATION IN CONFLICT WITH ANY INDUSTRIAL PROPERTY OR INTELLECTUAL PROPERTY RIGHTS, AND PERIMETER SOLUTIONS MAKES NO REPRESENTATION OR WARRANTY, EXPRESS OR IMPLIED, THAT THE USE THEREOF WILL NOT INFRINGE ON ANY INDUSTRIAL PROPERTY OR INTELLECTUAL PROPERTY RIGHTS. NO REPRESENTATIONS OR WARRANTIES, EITHER EXPRESSED OR IMPLIED, OF MERCHANTABILITY, FITNESS FOR A PARTICULAR PURPOSE OR OF ANY OTHER NATURE ARE MADE HEREUNDER WITH RESPECT TO THE INFORMATION CONTAINED HEREIN.

SOLBERG® PRE-PIPED BLADDER TANKS – HORIZONTAL & VERTICAL

FEATURES

- UL Listed with SOLBERG foam concentrates
- FM Approved with SOLBERG® RE-HEALING™ RF3, 3% and SOLBERG® ARCTIC™ 3x3% ATC™ Foam Concentrates
- Accurate concentrate proportioning permits operation over a wide range of flow rates
- All tanks have thermal expansion allowance for foam concentrates
- Design simplicity minimizes system failure due to mechanical issues
- Ease of operation, requires no outside source of power
- Ease of retrofit into existing water based extinguishing systems
- Manual system with automatic option available
- Minimized installation costs compared to other proportioning methods
- Uses existing water pressure for delivery of foam solution to the discharge devices

DESCRIPTION

SOLBERG® Pre-piped Bladder Tanks are the main component in a balanced pressure proportioning bladder tank system that requires no outside power source other than adequate water supply.

The SOLBERG Pre-piped Bladder Tank is a carbon steel pressure vessel that uses a nylon reinforced neoprene rubber bladder to store the foam concentrate. During operation the foam concentrate is discharged from the tank by the water supply, which collapses the bladder around the perforated center tube until concentrate is depleted. SOLBERG Pre-piped Bladder Tanks are available in both vertical and horizontal versions in multiple sizes.

APPLICATION

SOLBERG Pre-piped Bladder Tanks can be used in multiple high-hazard, high-risk applications including aircraft hangars, foam-water sprinkler systems, helipads, and truck loading racks.

SPECIFICATIONS

Vertical and horizontal pre-piped bladder tanks are manufactured in compliance with ASME Code Section VIII Division 1 with a design working pressure of 175 psi (12 bar) and tested to 263 psi (18 bar) — 1.5 times the working pressure. The tank is constructed out of SA 516 Grade 70 carbon steel with a nylon reinforced neoprene rubber bladder. It has a perforated center tube, and a .37" (9 mm) water channel between the water inlet and water drain valve, which creates a water path between the bladder and tank shell. Openings that



are greater than 1.0" (25 mm) will be divided to prevent bladder damage.

Pre-piped vertical bladder tank construction shall be mounted on a full skirt with four tabs drilled for anchoring.

Pre-piped horizontal bladder tank construction shall be mounted on four legs permanently welded and drilled for anchoring.

All pre-piped bladder tanks are furnished with lifting lugs, ASME welded nameplate, 1.0" (2.5 cm) bronze trim valves with locking handle in accordance with NFPA Standard 11, and Solberg Operation and Maintenance Manual.

The exterior of all pre-piped bladder tanks will be prepared and finished with Solberg standard blue or red enamel finish.

OPTIONS

- 100% X-Ray design
- Carbon or stainless steel construction
- Custom tank size and dimensions
- Epoxy or coal tar inner liner
- Inspection service
- National board registration
- Pressure relief valve*
- Seismic calculations
- Sight gage assembly
- Start-up and commission service

CERTIFICATIONS

American Society of Mechanical Engineers (ASME), Underwriters Laboratories, Inc. (UL) Listed – Standard 162, FM Approved per Approval Standard 5130.

*Not Part of FM Approval

SOLBERG® PRE-PIPED BLADDER TANKS – HORIZONTAL & VERTICAL

DIMENSIONAL INFORMATION - HORIZONTAL

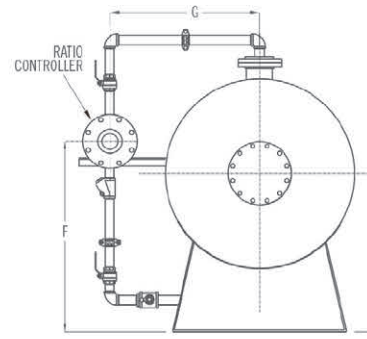
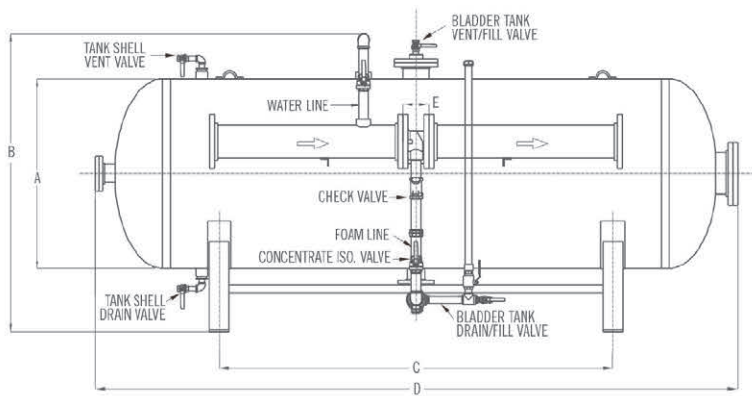

SADDLE FOR TANK

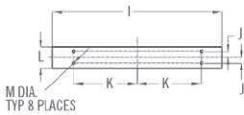

Prop. Diameter	E Upstream and Downstream Minimum Length			
	inch	mm	inch	mm
2	7	178	10	254
2.5	7	178	12.5	318
3	2.38	61	15	381
4	2.63	67	20	508
6	3.25	83	30	762
6 VRP	2.75	70	30	762
8	3.5	89	40	1016

NOMINAL TANK SIZE

DIMENSIONS Inches (Millimeters)

Gallon (Litre)	A	B	C	D	F	G	H	I	J	K	L	M
50 (189)	20 (508)	41.5 (1055)	14 (356)	55.5 (1410)	35 (889)	24 (610)	22 (559)	20 (508)	0.875 (23)	7 (178)	3 (77)	0.5625 (15)
100 (379)	24 (610)	45.5 (1156)	22 (559)	72 (1829)	35 (889)	26 (661)	24 (610)	24 (610)	0.875 (23)	9 (229)	3 (77)	0.5625 (15)
150 (568)	30 (762)	51.5 (1309)	36 (915)	71 (1804)	38 (966)	29 (737)	27 (686)	30 (762)	1.125 (29)	11 (280)	4 (102)	0.5625 (15)
200 (757)	30 (762)	51.5 (1309)	34 (864)	89 (2261)	38 (966)	29 (737)	27 (686)	30 (762)	1.125 (29)	11 (280)	4 (102)	0.5625 (15)
300 (1136)	36 (915)	58 (1474)	36 (915)	93 (2363)	52 (1321)	32 (813)	30 (762)	34 (864)	1.125 (29)	13 (331)	4 (102)	0.5625 (15)
400 (1514)	42 (1067)	64 (1626)	50 (1270)	93 (2363)	52 (1321)	35 (889)	33 (839)	40 (1016)	1.375 (35)	15 (381)	5 (127)	0.6875 (18)
500 (1893)	42 (1067)	64 (1626)	48 (1220)	112 (2845)	52 (1321)	35 (889)	33 (839)	40 (1016)	1.375 (35)	15 (381)	5 (127)	0.6875 (18)
600 (2271)	42 (1067)	64 (1626)	60 (1524)	131 (3328)	52 (1321)	35 (889)	33 (839)	40 (1016)	1.375 (35)	15 (381)	5 (127)	0.6875 (18)
700 (2650)	48 (1220)	74 (1880)	50 (1270)	119 (3023)	60 (1524)	38 (966)	40 (1016)	44 (1118)	1.375 (35)	17 (432)	5 (127)	0.6875 (18)
800 (3028)	48 (1220)	74 (1880)	60 (1524)	134 (3404)	60 (1524)	38 (966)	40 (1016)	44 (1118)	1.375 (35)	17 (432)	5 (127)	0.6875 (18)
900 (3407)	48 (1220)	74 (1880)	70 (1778)	148 (3760)	60 (1524)	38 (966)	40 (1016)	44 (1118)	1.375 (35)	17 (432)	5 (127)	0.6875 (18)
1000 (3785)	48 (1220)	74 (1880)	94 (2388)	163 (4141)	60 (1524)	38 (966)	40 (1016)	44 (1118)	1.375 (35)	17 (432)	5 (127)	0.6875 (18)
1100 (4164)	48 (1220)	74 (1880)	100 (2540)	177 (4496)	60 (1524)	38 (966)	40 (1016)	44 (1118)	1.375 (35)	17 (432)	5 (127)	0.6875 (18)
1200 (4542)	60 (1524)	86 (2185)	58 (1474)	131 (3328)	60 (1524)	44 (1118)	46 (1169)	54 (1372)	1.75 (45)	22 (559)	6 (153)	0.6875 (18)
1300 (4921)	60 (1524)	86 (2185)	60 (1524)	141 (3582)	60 (1524)	44 (1118)	46 (1169)	54 (1372)	1.75 (45)	22 (559)	6 (153)	0.6875 (18)
1400 (5299)	60 (1524)	86 (2185)	76 (1931)	151 (3836)	60 (1524)	44 (1118)	46 (1169)	54 (1372)	1.75 (45)	22 (559)	6 (153)	0.6875 (18)
1500 (5678)	60 (1524)	86 (2185)	80 (2032)	159 (4039)	60 (1524)	44 (1118)	46 (1169)	54 (1372)	1.75 (45)	22 (559)	6 (153)	0.6875 (18)
1600 (6056)	72 (1829)	96 (2439)	44 (1118)	125 (3175)	70 (1778)	50 (1270)	50 (1270)	64 (1626)	2.75 (70)	28 (712)	8 (204)	1.0625 (27)
1800 (6813)	72 (1829)	96 (2439)	56 (1423)	138 (3506)	70 (1778)	50 (1270)	50 (1270)	64 (1626)	2.75 (70)	28 (712)	8 (204)	1.0625 (27)
1900 (7192)	72 (1829)	96 (2439)	60 (1524)	144 (3658)	70 (1778)	50 (1270)	50 (1270)	64 (1626)	2.75 (70)	28 (712)	8 (204)	1.0625 (27)
2000 (7570)	72 (1829)	96 (2439)	70 (1778)	151 (3836)	70 (1778)	50 (1270)	50 (1270)	64 (1626)	2.75 (70)	28 (712)	8 (204)	1.0625 (27)
2200 (8327)	72 (1829)	96 (2439)	80 (2032)	164 (4166)	70 (1778)	50 (1270)	50 (1270)	64 (1626)	2.75 (70)	28 (712)	8 (204)	1.0625 (27)
2400 (9084)	72 (1829)	96 (2439)	80 (2032)	177 (4496)	70 (1778)	50 (1270)	50 (1270)	64 (1626)	2.75 (70)	28 (712)	8 (204)	1.0625 (27)
2600 (9841)	72 (1829)	96 (2439)	100 (2540)	189 (4801)	70 (1778)	50 (1270)	50 (1270)	64 (1626)	2.75 (70)	28 (712)	8 (204)	1.0625 (27)
2800 (10598)	72 (1829)	96 (2439)	100 (2540)	202 (5131)	70 (1778)	50 (1270)	50 (1270)	64 (1626)	2.75 (70)	28 (712)	8 (204)	1.0625 (27)
3000 (11355)	72 (1829)	96 (2439)	120 (3048)	215 (5461)	70 (1778)	50 (1270)	50 (1270)	64 (1626)	2.75 (70)	28 (712)	8 (204)	1.0625 (27)
3200 (12112)	72 (1829)	96 (2439)	120 (3048)	228 (5792)	70 (1778)	50 (1270)	50 (1270)	64 (1626)	2.75 (70)	28 (712)	8 (204)	1.0625 (27)
3300 (12491)	72 (1829)	96 (2439)	120 (3048)	234 (5944)	70 (1778)	50 (1270)	50 (1270)	64 (1626)	2.75 (70)	28 (712)	8 (204)	1.0625 (27)

SOLBERG® PRE-PIPED BLADDER TANKS – HORIZONTAL & VERTICAL

DIMENSIONAL INFORMATION - VERTICAL

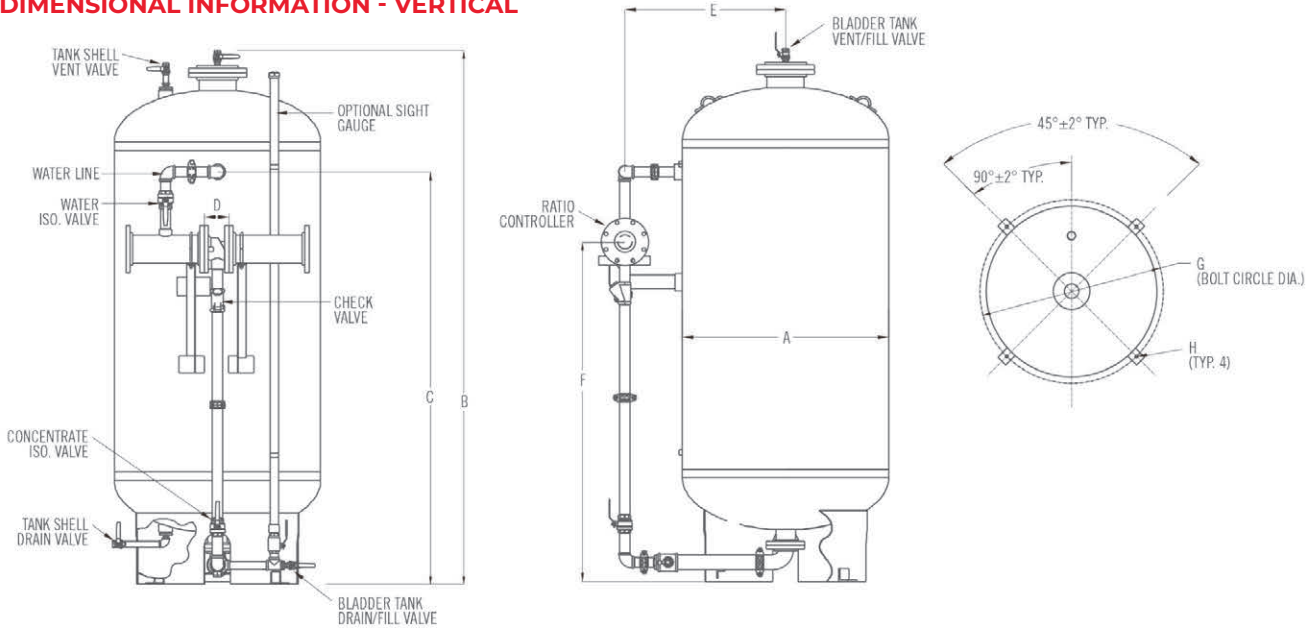

NOMINAL TANK SIZE

DIMENSIONS Inches (Millimeters)

Gallon (Litre)	A	B	C	E	F	G	H
36 (136)	24 (610)	52 (1321)	46.5 (1182)	26 (661)	35 (889)	26.75 (680)	0.5625 (15)
50 (189)	24 (610)	60 (1524)	54.5 (1385)	26 (661)	42 (1067)	26.75 (680)	0.5625 (15)
100 (379)	24 (610)	89 (2261)	83.5 (2121)	26 (661)	45 (1143)	26.75 (680)	0.5625 (15)
150 (568)	30 (762)	88 (2236)	82.5 (2096)	29 (737)	48 (1220)	27.75 (705)	0.5625 (15)
200 (757)	30 (762)	107 (2718)	101 (2566)	29 (737)	48 (1220)	27.75 (705)	0.5625 (15)
300 (1136)	36 (915)	111 (2820)	105 (2667)	32 (813)	60 (1524)	32.75 (832)	0.5625 (15)
400 (1514)	42 (1067)	105 (2667)	99 (2515)	35 (889)	65 (1651)	41.5 (1055)	0.6875 (18)
500 (1893)	42 (1067)	130 (3302)	124 (3150)	35 (889)	65 (1651)	41.5 (1055)	0.6875 (18)
600 (2271)	48 (1220)	123 (3125)	117 (2972)	38 (966)	65 (1651)	41.5 (1055)	0.6875 (18)
700 (2650)	48 (1220)	137 (3480)	131 (3328)	38 (966)	65 (1651)	41.5 (1055)	0.6875 (18)
800 (3028)	48 (1220)	155 (3937)	149 (3785)	38 (966)	65 (1651)	51.5 (1309)	0.6875 (18)
900 (3407)	60 (1524)	125 (3175)	119 (3023)	44 (1118)	75 (1905)	51.5 (1309)	0.6875 (18)
1000 (3785)	60 (1524)	135 (3429)	129 (3277)	44 (1118)	75 (1905)	51.5 (1309)	0.8125 (21)
1100 (4164)	60 (1524)	144 (3658)	138 (3506)	44 (1118)	75 (1905)	51.5 (1309)	0.8125 (21)
1200 (4542)	60 (1524)	153 (3887)	147 (3734)	44 (1118)	75 (1905)	51.5 (1309)	0.8125 (21)
1300 (4921)	60 (1524)	163 (4141)	157 (3988)	44 (1118)	75 (1905)	51.5 (1309)	0.8125 (21)
1400 (5299)	60 (1524)	172 (4369)	166 (4217)	44 (1118)	75 (1905)	51.5 (1309)	0.8125 (21)
1500 (5678)	60 (1524)	181 (4598)	175 (4445)	44 (1118)	75 (1905)	51.5 (1309)	0.8125 (21)
1600 (6056)	72 (1829)	147 (3734)	141 (3582)	50 (1270)	80 (2032)	57.5 (1461)	0.8125 (21)
1700 (6435)	72 (1829)	153 (3887)	147 (3734)	50 (1270)	80 (2032)	57.5 (1461)	0.8125 (21)

SOLBERG® PRE-PIPED BLADDER TANKS – HORIZONTAL & VERTICAL

ORDERING INFORMATION - HORIZONTAL

BLADDER TANKS - HORIZONTAL / PRE-PIPED		APPROXIMATE EMPTY WEIGHT	
PART NO.	DESCRIPTION	lb	kg
22201B	Bladder Tank, Pre-piped w/2" Prop. 50 gallon Horizontal, Blue Enamel Finish	428.5	195
22201R	Bladder Tank, Pre-piped w/2" Prop. 50 gallon Horizontal, Red Enamel Finish	428.5	195
22202B	Bladder Tank, Pre-piped w/2-1/2" Prop. 50 gallon Horizontal, Blue Enamel Finish	451	205
22202R	Bladder Tank, Pre-piped w/2-1/2" Prop. 50 gallon Horizontal, Red Enamel Finish	451	205
22203B	Bladder Tank, Pre-piped w/2" Prop. 100 gallon Horizontal, Blue Enamel Finish	719.5	327
22203R	Bladder Tank, Pre-piped w/2" Prop. 100 gallon Horizontal, Red Enamel Finish	719.5	327
22204B	Bladder Tank, Pre-piped w/2-1/2" Prop. 100 gallon Horizontal, Blue Enamel Finish	742	337
22204R	Bladder Tank, Pre-piped w/2-1/2" Prop. 100 gallon Horizontal, Red Enamel Finish	742	337
22205B	Bladder Tank, Pre-piped w/3" Prop. 100 gallon Horizontal, Blue Enamel Finish	819.6	372
22205R	Bladder Tank, Pre-piped w/3" Prop. 100 gallon Horizontal, Red Enamel Finish	819.6	372
22206B	Bladder Tank, Pre-piped w/2-1/2" Prop. 150 gallon Horizontal, Blue Enamel Finish	1031	468
22206R	Bladder Tank, Pre-piped w/2-1/2" Prop. 150 gallon Horizontal, Red Enamel Finish	1031	468
22207B	Bladder Tank, Pre-piped w/3" Prop. 150 gallon Horizontal, Blue Enamel Finish	1108.6	503
22207R	Bladder Tank, Pre-piped w/3" Prop. 150 gallon Horizontal, Red Enamel Finish	1108.6	503
22208B	Bladder Tank, Pre-piped w/4" Prop. 150 gallon Horizontal, Blue Enamel Finish	1183.9	538
22208R	Bladder Tank, Pre-piped w/4" Prop. 150 gallon Horizontal, Red Enamel Finish	1183.9	538
22209B	Bladder Tank, Pre-piped w/3" Prop. 200 gallon Horizontal, Blue Enamel Finish	1305.6	593
22209R	Bladder Tank, Pre-piped w/3" Prop. 200 gallon Horizontal, Red Enamel Finish	1305.6	593
22210B	Bladder Tank, Pre-piped w/4" Prop. 200 gallon Horizontal, Blue Enamel Finish	1380.9	627
22210R	Bladder Tank, Pre-piped w/4" Prop. 200 gallon Horizontal, Red Enamel Finish	1380.9	627
22211B	Bladder Tank, Pre-piped w/6" Prop. 200 gallon Horizontal, Blue Enamel Finish	1536.3	697
22211R	Bladder Tank, Pre-piped w/6" Prop. 200 gallon Horizontal, Red Enamel Finish	1536.3	697
22212B	Bladder Tank, Pre-piped w/3" Prop. 300 gallon Horizontal, Blue Enamel Finish	1722.6	782
22212R	Bladder Tank, Pre-piped w/3" Prop. 300 gallon Horizontal, Red Enamel Finish	1722.6	782
22213B	Bladder Tank, Pre-piped w/4" Prop. 300 gallon Horizontal, Blue Enamel Finish	1797.9	816
22213R	Bladder Tank, Pre-piped w/4" Prop. 300 gallon Horizontal, Red Enamel Finish	1797.9	816
22214B	Bladder Tank, Pre-piped w/6" Prop. 300 gallon Horizontal, Blue Enamel Finish	1953.3	887
22214R	Bladder Tank, Pre-piped w/6" Prop. 300 gallon Horizontal, Red Enamel Finish	1953.3	887
22215B	Bladder Tank, Pre-piped w/4" Prop. 400 gallon Horizontal, Blue Enamel Finish	2113.9	959
22215R	Bladder Tank, Pre-piped w/4" Prop. 400 gallon Horizontal, Red Enamel Finish	2113.9	959
22216B	Bladder Tank, Pre-piped w/6" Prop. 400 gallon Horizontal, Blue Enamel Finish	2269.3	1030
22216R	Bladder Tank, Pre-piped w/6" Prop. 400 gallon Horizontal, Red Enamel Finish	2269.3	1030
22217B	Bladder Tank, Pre-piped w/8" Prop. 400 gallon Horizontal, Blue Enamel Finish	2505.2	1137
22217R	Bladder Tank, Pre-piped w/8" Prop. 400 gallon Horizontal, Red Enamel Finish	2505.2	1137
22218B	Bladder Tank, Pre-piped w/4" Prop. 500 gallon Horizontal, Blue Enamel Finish	2373.9	1077
22218R	Bladder Tank, Pre-piped w/4" Prop. 500 gallon Horizontal, Red Enamel Finish	2373.9	1077
22219B	Bladder Tank, Pre-piped w/6" Prop. 500 gallon Horizontal, Blue Enamel Finish	2529.3	1148
22219R	Bladder Tank, Pre-piped w/6" Prop. 500 gallon Horizontal, Red Enamel Finish	2529.3	1148
22220B	Bladder Tank, Pre-piped w/8" Prop. 500 gallon Horizontal, Blue Enamel Finish	2765.2	1255
22220R	Bladder Tank, Pre-piped w/8" Prop. 500 gallon Horizontal, Red Enamel Finish	2765.2	1255

SOLBERG® PRE-PIPED BLADDER TANKS – HORIZONTAL & VERTICAL

ORDERING INFORMATION - HORIZONTAL CONTINUED

BLADDER TANKS - HORIZONTAL / PRE-PIPED		APPROXIMATE EMPTY WEIGHT	
PART NO.	DESCRIPTION	lb	kg
22221B	Bladder Tank, Pre-piped w/4" Prop. 600 gallon Horizontal, Blue Enamel Finish	2480.9	1126
22221R	Bladder Tank, Pre-piped w/4" Prop. 600 gallon Horizontal, Red Enamel Finish	2480.9	1126
22222B	Bladder Tank, Pre-piped w/6" prop. 600 gallon Horizontal, Blue Enamel Finish	2636.3	1196
22222R	Bladder Tank, Pre-piped w/6" prop. 600 gallon Horizontal, Red Enamel Finish	2636.3	1196
22223B	Bladder Tank, Pre-piped w/8" prop. 600 gallon Horizontal, Blue Enamel Finish	2872.2	1303
22223R	Bladder Tank, Pre-piped w/8" prop. 600 gallon Horizontal, Red Enamel Finish	2872.2	1303
22224B	Bladder Tank, Pre-piped w/4" prop. 700 gallon Horizontal, Blue Enamel Finish	2887.9	1310
22224R	Bladder Tank, Pre-piped w/4" prop. 700 gallon Horizontal, Red Enamel Finish	2887.9	1310
22225B	Bladder Tank, Pre-piped w/6" prop. 700 gallon Horizontal, Blue Enamel Finish	3043.3	1381
22225R	Bladder Tank, Pre-piped w/6" prop. 700 gallon Horizontal, Red Enamel Finish	3043.3	1381
22226B	Bladder Tank, Pre-piped w/8" prop. 700 gallon Horizontal, Blue Enamel Finish	3279.2	1488
22226R	Bladder Tank, Pre-piped w/8" prop. 700 gallon Horizontal, Red Enamel Finish	3279.2	1488
22227B	Bladder Tank, Pre-piped w/4" prop. 800 gallon Horizontal, Blue Enamel Finish	3541.9	1607
22227R	Bladder Tank, Pre-piped w/4" prop. 800 gallon Horizontal, Red Enamel Finish	3541.9	1607
22228B	Bladder Tank, Pre-piped w/6" prop. 800 gallon Horizontal, Blue Enamel Finish	3697.3	1678
22228R	Bladder Tank, Pre-piped w/6" prop. 800 gallon Horizontal, Red Enamel Finish	3697.3	1678
22229B	Bladder Tank, Pre-piped w/8" prop. 800 gallon Horizontal, Blue Enamel Finish	3933.2	1785
22229R	Bladder Tank, Pre-piped w/8" prop. 800 gallon Horizontal, Red Enamel Finish	3933.2	1785
22230B	Bladder Tank, Pre-piped w/4" prop. 900 gallon Horizontal, Blue Enamel Finish	3898.9	1769
22230R	Bladder Tank, Pre-piped w/4" prop. 900 gallon Horizontal, Red Enamel Finish	3898.9	1769
22231B	Bladder Tank, Pre-piped w/6" prop. 900 gallon Horizontal, Blue Enamel Finish	4054.3	1839
22231R	Bladder Tank, Pre-piped w/6" prop. 900 gallon Horizontal, Red Enamel Finish	4054.3	1839
22232B	Bladder Tank, Pre-piped w/8" prop. 900 gallon Horizontal, Blue Enamel Finish	4290.2	1947
22232R	Bladder Tank, Pre-piped w/8" prop. 900 gallon Horizontal, Red Enamel Finish	4290.2	1947
22233B	Bladder Tank, Pre-piped w/4" prop. 1000 gallon Horizontal, Blue Enamel Finish	4115.9	1867
22233R	Bladder Tank, Pre-piped w/4" prop. 1000 gallon Horizontal, Red Enamel Finish	4115.9	1867
22234B	Bladder Tank, Pre-piped w/6" prop. 1000 gallon Horizontal, Blue Enamel Finish	4271.3	1938
22234R	Bladder Tank, Pre-piped w/6" prop. 1000 gallon Horizontal, Red Enamel Finish	4271.3	1938
22235B	Bladder Tank, Pre-piped w/8" prop. 1000 gallon Horizontal, Blue Enamel Finish	4507.2	2045
22235R	Bladder Tank, Pre-piped w/8" prop. 1000 gallon Horizontal, Red Enamel Finish	4507.2	2045
22236B	Bladder Tank, Pre-piped w/4" prop. 1100 gallon Horizontal, Blue Enamel Finish	4499.9	2042
22236R	Bladder Tank, Pre-piped w/4" prop. 1100 gallon Horizontal, Red Enamel Finish	4499.9	2042
22237B	Bladder Tank, Pre-piped w/6" prop. 1100 gallon Horizontal, Blue Enamel Finish	4655.3	2112
22237R	Bladder Tank, Pre-piped w/6" prop. 1100 gallon Horizontal, Red Enamel Finish	4655.3	2112
22238B	Bladder Tank, Pre-piped w/8" prop. 1100 gallon Horizontal, Blue Enamel Finish	4891.2	2219
22238R	Bladder Tank, Pre-piped w/8" prop. 1100 gallon Horizontal, Red Enamel Finish	4891.2	2219
22219B	Bladder Tank, Pre-piped w/6" Prop. 500 gallon Horizontal, Blue Enamel Finish	2529.3	1148
22219R	Bladder Tank, Pre-piped w/6" Prop. 500 gallon Horizontal, Red Enamel Finish	2529.3	1148
22220B	Bladder Tank, Pre-piped w/8" Prop. 500 gallon Horizontal, Blue Enamel Finish	2765.2	1255
22220R	Bladder Tank, Pre-piped w/8" Prop. 500 gallon Horizontal, Red Enamel Finish	2765.2	1255

SOLBERG® PRE-PIPED BLADDER TANKS – HORIZONTAL & VERTICAL

ORDERING INFORMATION - HORIZONTAL CONTINUED

BLADDER TANKS - HORIZONTAL / PRE-PIPED		APPROXIMATE EMPTY WEIGHT	
PART NO.	DESCRIPTION	lb	kg
22239B	Bladder Tank, Pre-piped w/4" prop. 1200 gallon Horizontal, Blue Enamel Finish	4566.9	2072
22239R	Bladder Tank, Pre-piped w/4" prop. 1200 gallon Horizontal, Red Enamel Finish	4566.9	2072
22240B	Bladder Tank, Pre-piped w/6" prop. 1200 gallon Horizontal, Blue Enamel Finish	4722.3	2142
22240R	Bladder Tank, Pre-piped w/6" prop. 1200 gallon Horizontal, Red Enamel Finish	4722.3	2142
22241B	Bladder Tank, Pre-piped w/8" prop. 1200 gallon Horizontal, Blue Enamel Finish	4958.2	2250
22241R	Bladder Tank, Pre-piped w/8" prop. 1200 gallon Horizontal, Red Enamel Finish	4958.2	2250
22242B	Bladder Tank, Pre-piped w/4" prop. 1300 gallon Horizontal, Blue Enamel Finish	4869.9	2209
22242R	Bladder Tank, Pre-piped w/4" prop. 1300 gallon Horizontal, Red Enamel Finish	4869.9	2209
22243B	Bladder Tank, Pre-piped w/6" prop. 1300 gallon Horizontal, Blue Enamel Finish	5025.3	2280
22243R	Bladder Tank, Pre-piped w/6" prop. 1300 gallon Horizontal, Red Enamel Finish	5025.3	2280
22244B	Bladder Tank, Pre-piped w/8" prop. 1300 gallon Horizontal, Blue Enamel Finish	5261.2	2387
22244R	Bladder Tank, Pre-piped w/8" prop. 1300 gallon Horizontal, Red Enamel Finish	5261.2	2387
22245B	Bladder Tank, Pre-piped w/4" prop. 1400 gallon Horizontal, Blue Enamel Finish	5156.9	2340
22245R	Bladder Tank, Pre-piped w/4" prop. 1400 gallon Horizontal, Red Enamel Finish	5156.9	2340
22246B	Bladder Tank, Pre-piped w/6" prop. 1400 gallon Horizontal, Blue Enamel Finish	5312.3	2410
22246R	Bladder Tank, Pre-piped w/6" prop. 1400 gallon Horizontal, Red Enamel Finish	5312.3	2410
22247B	Bladder Tank, Pre-piped w/8" prop. 1400 gallon Horizontal, Blue Enamel Finish	5548.2	2517
22247R	Bladder Tank, Pre-piped w/8" prop. 1400 gallon Horizontal, Red Enamel Finish	5548.2	2517
22248B	Bladder Tank, Pre-piped w/4" prop. 1500 gallon Horizontal, Blue Enamel Finish	5537.9	2512
22248R	Bladder Tank, Pre-piped w/4" prop. 1500 gallon Horizontal, Red Enamel Finish	5537.9	2512
22249B	Bladder Tank, Pre-piped w/6" prop. 1500 gallon Horizontal, Blue Enamel Finish	5693.3	2583
22249R	Bladder Tank, Pre-piped w/6" prop. 1500 gallon Horizontal, Red Enamel Finish	5693.3	2583
22250B	Bladder Tank, Pre-piped w/8" prop. 1500 gallon Horizontal, Blue Enamel Finish	5929.2	2690
22250R	Bladder Tank, Pre-piped w/8" prop. 1500 gallon Horizontal, Red Enamel Finish	5929.2	2690
22251B	Bladder Tank, Pre-piped w/4" prop. 1600 gallon Horizontal, Blue Enamel Finish	4934.9	2239
22251R	Bladder Tank, Pre-piped w/4" prop. 1600 gallon Horizontal, Red Enamel Finish	4934.9	2239
22252B	Bladder Tank, Pre-piped w/6" prop. 1600 gallon Horizontal, Blue Enamel Finish	5090.3	2309
22252R	Bladder Tank, Pre-piped w/6" prop. 1600 gallon Horizontal, Red Enamel Finish	5090.3	2309
22253B	Bladder Tank, Pre-piped w/8" prop. 1600 gallon Horizontal, Blue Enamel Finish	5326.2	2416
22253R	Bladder Tank, Pre-piped w/8" prop. 1600 gallon Horizontal, Red Enamel Finish	5326.2	2416
22254B	Bladder Tank, Pre-piped w/6" prop. 1800 gallon Horizontal, Blue Enamel Finish	5453.3	2474
22254R	Bladder Tank, Pre-piped w/6" prop. 1800 gallon Horizontal, Red Enamel Finish	5453.3	2474
22255B	Bladder Tank, Pre-piped w/8" prop. 1800 gallon Horizontal, Blue Enamel Finish	5689.2	2581
22255R	Bladder Tank, Pre-piped w/8" prop. 1800 gallon Horizontal, Red Enamel Finish	5689.2	2581
22256B	Bladder Tank, Pre-piped w/6" prop. 1900 gallon Horizontal, Blue Enamel Finish	5678.3	2576
22256R	Bladder Tank, Pre-piped w/6" prop. 1900 gallon Horizontal, Red Enamel Finish	5678.3	2576
22257B	Bladder Tank, Pre-piped w/8" prop. 1900 gallon Horizontal, Blue Enamel Finish	5914.2	2683
22257R	Bladder Tank, Pre-piped w/8" prop. 1900 gallon Horizontal, Red Enamel Finish	5914.2	2683

SOLBERG® PRE-PIPED BLADDER TANKS – HORIZONTAL & VERTICAL

ORDERING INFORMATION - HORIZONTAL CONTINUED

BLADDER TANKS - HORIZONTAL / PRE-PIPED		APPROXIMATE EMPTY WEIGHT	
PART NO.	DESCRIPTION	lb	kg
22258B	Bladder Tank, Pre-piped w/6" prop. 2000 gallon Horizontal, Blue Enamel Finish	5903.3	2678
22258R	Bladder Tank, Pre-piped w/6" prop. 2000 gallon Horizontal, Red Enamel Finish	5903.3	2678
22259B	Bladder Tank, Pre-piped w/8" prop. 2000 gallon Horizontal, Blue Enamel Finish	6139.2	2785
22259R	Bladder Tank, Pre-piped w/8" prop. 2000 gallon Horizontal, Red Enamel Finish	6139.2	2785
22260B	Bladder Tank, Pre-piped w/6" prop. 2200 gallon Horizontal, Blue Enamel Finish	6286.3	2852
22260R	Bladder Tank, Pre-piped w/6" prop. 2200 gallon Horizontal, Red Enamel Finish	6286.3	2852
22261B	Bladder Tank, Pre-piped w/8" prop. 2200 gallon Horizontal, Blue Enamel Finish	6522.2	2959
22261R	Bladder Tank, Pre-piped w/8" prop. 2200 gallon Horizontal, Red Enamel Finish	6522.2	2959
22262B	Bladder Tank, Pre-piped w/6" prop. 2400 gallon Horizontal, Blue Enamel Finish	6698.3	3039
22262R	Bladder Tank, Pre-piped w/6" prop. 2400 gallon Horizontal, Red Enamel Finish	6698.3	3039
22263B	Bladder Tank, Pre-piped w/8" prop. 2400 gallon Horizontal, Blue Enamel Finish	6934.2	3146
22263R	Bladder Tank, Pre-piped w/8" prop. 2400 gallon Horizontal, Red Enamel Finish	6934.2	3146
22264B	Bladder Tank, Pre-piped w/6" prop. 2600 gallon Horizontal, Blue Enamel Finish	7098.3	3220
22264R	Bladder Tank, Pre-piped w/6" prop. 2600 gallon Horizontal, Red Enamel Finish	7098.3	3220
22265B	Bladder Tank, Pre-piped w/8" prop. 2600 gallon Horizontal, Blue Enamel Finish	7334.2	3327
22265R	Bladder Tank, Pre-piped w/8" prop. 2600 gallon Horizontal, Red Enamel Finish	7334.2	3327
22266B	Bladder Tank, Pre-piped w/6" prop. 2800 gallon Horizontal, Blue Enamel Finish	7477.3	3392
22266R	Bladder Tank, Pre-piped w/6" prop. 2800 gallon Horizontal, Red Enamel Finish	7477.3	3392
22267B	Bladder Tank, Pre-piped w/8" prop. 2800 gallon Horizontal, Blue Enamel Finish	7713.2	3499
22267R	Bladder Tank, Pre-piped w/8" prop. 2800 gallon Horizontal, Red Enamel Finish	7713.2	3499
22268B	Bladder Tank, Pre-piped w/6" prop. 3000 gallon Horizontal, Blue Enamel Finish	7877.3	3574
22268R	Bladder Tank, Pre-piped w/6" prop. 3000 gallon Horizontal, Red Enamel Finish	7877.3	3574
22269B	Bladder Tank, Pre-piped w/8" prop. 3000 gallon Horizontal, Blue Enamel Finish	8113.2	3681
22269R	Bladder Tank, Pre-piped w/8" prop. 3000 gallon Horizontal, Red Enamel Finish	8113.2	3681
22270B	Bladder Tank, Pre-piped w/6" prop. 3200 gallon Horizontal, Blue Enamel Finish	8279.3	3756
22270R	Bladder Tank, Pre-piped w/6" prop. 3200 gallon Horizontal, Red Enamel Finish	8279.3	3756
22271B	Bladder Tank, Pre-piped w/8" prop. 3200 gallon Horizontal, Blue Enamel Finish	8515.2	3863
22271R	Bladder Tank, Pre-piped w/8" prop. 3200 gallon Horizontal, Red Enamel Finish	8515.2	3863
22272B	Bladder Tank, Pre-piped w/6" prop. 3300 gallon Horizontal, Blue Enamel Finish	8499.3	3856
22272R	Bladder Tank, Pre-piped w/6" prop. 3300 gallon Horizontal, Red Enamel Finish	8499.3	3856
22273B	Bladder Tank, Pre-piped w/8" prop. 3300 gallon Horizontal, Blue Enamel Finish	8735.2	3963
22273R	Bladder Tank, Pre-piped w/8" prop. 3300 gallon Horizontal, Red Enamel Finish	8735.2	3963

SOLBERG® PRE-PIPED BLADDER TANKS – HORIZONTAL & VERTICAL

ORDERING INFORMATION - VERTICAL CONTINUED

BLADDER TANKS - VERTICAL / PRE-PIPED		APPROXIMATE EMPTY WEIGHT	
PART NO.	DESCRIPTION	lb	kg
22618B	Bladder Tank, Pre-piped w/4" Prop. 500 gallon Vertical, Blue Enamel Finish	1701	772
22618R	Bladder Tank, Pre-piped w/4" Prop. 500 gallon Vertical, Red Enamel Finish	1701	772
22619B	Bladder Tank, Pre-piped w/6" Prop. 500 gallon Vertical, Blue Enamel Finish	1857.1	843
22619R	Bladder Tank, Pre-piped w/6" Prop. 500 gallon Vertical, Red Enamel Finish	1857.1	843
22620B	Bladder Tank, Pre-piped w/8" Prop. 500 gallon Vertical, Blue Enamel Finish	2094.6	951
22620R	Bladder Tank, Pre-piped w/8" Prop. 500 gallon Vertical, Red Enamel Finish	2094.6	951
22621B	Bladder Tank, Pre-piped w/4" Prop. 600 gallon Vertical, Blue Enamel Finish	1796	815
22621R	Bladder Tank, Pre-piped w/4" Prop. 600 gallon Vertical, Red Enamel Finish	1796	815
22622B	Bladder Tank, Pre-piped w/6" Prop. 600 gallon Vertical, Blue Enamel Finish	1952.1	886
22622R	Bladder Tank, Pre-piped w/6" Prop. 600 gallon Vertical, Red Enamel Finish	1952.1	886
22623B	Bladder Tank, Pre-piped w/8" Prop. 600 gallon Vertical, Blue Enamel Finish	2189.6	994
22623R	Bladder Tank, Pre-piped w/8" Prop. 600 gallon Vertical, Red Enamel Finish	2189.6	994
22624B	Bladder Tank, Pre-piped w/4" Prop. 700 gallon Vertical, Blue Enamel Finish	1926	874
22624R	Bladder Tank, Pre-piped w/4" Prop. 700 gallon Vertical, Red Enamel Finish	1926	874
22625B	Bladder Tank, Pre-piped w/6" Prop. 700 gallon Vertical, Blue Enamel Finish	2082.1	945
22625R	Bladder Tank, Pre-piped w/6" Prop. 700 gallon Vertical, Red Enamel Finish	2082.1	945
22626B	Bladder Tank, Pre-piped w/8" Prop. 700 gallon Vertical, Blue Enamel Finish	2319.6	1053
22626R	Bladder Tank, Pre-piped w/8" Prop. 700 gallon Vertical, Red Enamel Finish	2319.6	1053
22627B	Bladder Tank, Pre-piped w/4" Prop. 800 gallon Vertical, Blue Enamel Finish	2126	965
22627R	Bladder Tank, Pre-piped w/4" Prop. 800 gallon Vertical, Red Enamel Finish	2126	965
22628B	Bladder Tank, Pre-piped w/6" Prop. 800 gallon Vertical, Blue Enamel Finish	2282.1	1036
22628R	Bladder Tank, Pre-piped w/6" Prop. 800 gallon Vertical, Red Enamel Finish	2282.1	1036
22629B	Bladder Tank, Pre-piped w/8" Prop. 800 gallon Vertical, Blue Enamel Finish	2519.6	1143
22629R	Bladder Tank, Pre-piped w/8" Prop. 800 gallon Vertical, Red Enamel Finish	2519.6	1143
22630B	Bladder Tank, Pre-piped w/4" Prop. 900 gallon Vertical, Blue Enamel Finish	2447.2	1111
22630R	Bladder Tank, Pre-piped w/4" Prop. 900 gallon Vertical, Red Enamel Finish	2447.2	1111
22631B	Bladder Tank, Pre-piped w/6" Prop. 900 gallon Vertical, Blue Enamel Finish	2604.2	1182
22631R	Bladder Tank, Pre-piped w/6" Prop. 900 gallon Vertical, Red Enamel Finish	2604.2	1182
22632B	Bladder Tank, Pre-piped w/8" Prop. 900 gallon Vertical, Blue Enamel Finish	2843	1290
22632R	Bladder Tank, Pre-piped w/8" Prop. 900 gallon Vertical, Red Enamel Finish	2843	1290
22633B	Bladder Tank, Pre-piped w/4" Prop. 1000 gallon Vertical, Blue Enamel Finish	2847.2	1292
22633R	Bladder Tank, Pre-piped w/4" Prop. 1000 gallon Vertical, Red Enamel Finish	2847.2	1292
22634B	Bladder Tank, Pre-piped w/6" Prop. 1000 gallon Vertical, Blue Enamel Finish	3004.2	1363
22634R	Bladder Tank, Pre-piped w/6" Prop. 1000 gallon Vertical, Red Enamel Finish	3004.2	1363
22635B	Bladder Tank, Pre-piped w/8" Prop. 1000 gallon Vertical, Blue Enamel Finish	3243	1472
22635R	Bladder Tank, Pre-piped w/8" Prop. 1000 gallon Vertical, Red Enamel Finish	3243	1472

SOLBERG® PRE-PIPED BLADDER TANKS – HORIZONTAL & VERTICAL

ORDERING INFORMATION - VERTICAL CONTINUED

RATIO CONTROLLERS / BETWEEN FLANGE		APPROXIMATE SHIPPING WEIGHT	
PART NO.	DESCRIPTION	lb	kg
30104	Ratio Controller - Between Flange, 3.0" (76 mm), RE-HEALING RF3, 3%	10	4
30108	Ratio Controller - Between Flange, 3.0" (76 mm), RE-HEALING RF6, 6%	10	4
30112	Ratio Controller - Between Flange, 3.0" (76 mm), SOLBERG HIGH-EXPANSION	10	4
30120	Ratio Controller - Between Flange, 3.0" (76 mm), ARCTIC 1% SP AFFF	10	4
30121	Ratio Controller - Between Flange, 3.0" (76 mm), ARCTIC 3% AFFF	10	4
30123	Ratio Controller - Between Flange, 3.0" (76 mm), ARCTIC 3% MIL-SPEC AFFF	10	4
30122	Ratio Controller - Between Flange, 3.0" (76 mm), ARCTIC 3x3% ATC	10	4
30105	Ratio Controller - Between Flange, 4.0" (102 mm), RE-HEALING RF3, 3%	16	7
30109	Ratio Controller - Between Flange, 4.0" (102 mm), RE-HEALING RF6, 6%	16	7
30113	Ratio Controller - Between Flange, 4.0" (102 mm), SOLBERG HIGH-EXPANSION	16	7
30130	Ratio Controller - Between Flange, 4.0" (102 mm), ARCTIC 1% AFFF	16	7
30134	Ratio Controller - Between Flange, 4.0" (102 mm), ARCTIC 1% SP AFFF	16	7
30131	Ratio Controller - Between Flange, 4.0" (102 mm), ARCTIC 3% AFFF	16	7
30133	Ratio Controller - Between Flange, 4.0" (102 mm), ARCTIC 3% MIL-SPEC AFFF	16	7
30132	Ratio Controller - Between Flange, 4.0" (102 mm), ARCTIC 3x3% ATC	16	7
30106	Ratio Controller - Between Flange, 6.0" (152 mm), RE-HEALING RF3, 3%	32	14
30110	Ratio Controller - Between Flange, 6.0" (152 mm), RE-HEALING RF6, 6%	32	14
30114	Ratio Controller - Between Flange, 6.0" (152 mm), SOLBERG HIGH-EXPANSION	32	14
30140	Ratio Controller - Between Flange, 6.0" (152 mm), ARCTIC 1% AFFF	32	14
30144	Ratio Controller - Between Flange, 6.0" (152 mm), ARCTIC 1% SP AFFF	32	14
30141	Ratio Controller - Between Flange, 6.0" (152 mm), ARCTIC 3% AFFF	32	14
30143	Ratio Controller - Between Flange, 6.0" (152 mm), ARCTIC 3% MIL-SPEC AFFF	32	14
30142	Ratio Controller - Between Flange, 6.0" (152 mm), ARCTIC 3x3% ATC	32	14
30107	Ratio Controller - Between Flange, 8.0" (203 mm), RE-HEALING RF3, 3%	53	24
30111	Ratio Controller - Between Flange, 8.0" (203 mm), RE-HEALING RF6, 6%	53	24
30115	Ratio Controller - Between Flange, 8.0" (203 mm), SOLBERG HIGH-EXPANSION	53	24
30150	Ratio Controller - Between Flange, 8.0" (203 mm), ARCTIC 1% SP AFFF	53	24
30151	Ratio Controller - Between Flange, 8.0" (203 mm), ARCTIC 3% AFFF	53	24
30153	Ratio Controller - Between Flange, 8.0" (203 mm), ARCTIC 3% MIL-SPEC AFFF	53	24
30152	Ratio Controller - Between Flange, 8.0" (203 mm), ARCTIC 3x3% ATC	53	24



Solutions That Save.

FOR MORE INFORMATION

Contact any of our worldwide Perimeter Solutions Fire Safety offices or visit:

www.Perimeter-Solutions.com

UNITED STATES

10667 Jersey Blvd.
Rancho Cucamonga, CA 91730
Tel: +1 800 682 3626
Tel: +1 909 983 0772
salesfoamusa@perimeter-solutions.com

EMEA

Polígono de Baiña, Parcela 23
33682 Mieres (Asturias)
Spain
Tel: +34 985 24 29 45
salesfoamea@perimeter-solutions.com

ASIA PACIFIC

3 Charles Street
St Marys NSW 2760 – Australia
Tel: +61 2 9673 5300
salesfoamapac@perimeter-solutions.com

perimeter-solutions.com

NOTICE PERIMETER SOLUTIONS MAKES NO REPRESENTATIONS OR WARRANTIES AS TO THE COMPLETENESS OR ACCURACY OF THE INFORMATION INCLUDED HEREIN. THE INFORMATION CONTAINED HEREIN IS NOT INTENDED TO PROVIDE REGULATORY, LEGAL OR EXPERT ADVICE RELATING TO THE PRODUCTS, ITS APPLICATION OR USES. NOTHING CONTAINED HEREIN IS TO BE CONSTRUED AS A RECOMMENDATION TO USE ANY PRODUCT, PROCESS, EQUIPMENT OR FORMULATION IN CONFLICT WITH ANY INDUSTRIAL PROPERTY OR INTELLECTUAL PROPERTY RIGHTS, AND PERIMETER SOLUTIONS MAKES NO REPRESENTATION OR WARRANTY, EXPRESS OR IMPLIED, THAT THE USE THEREOF WILL NOT INFRINGE ON ANY INDUSTRIAL PROPERTY OR INTELLECTUAL PROPERTY RIGHTS. NO REPRESENTATIONS OR WARRANTIES, EITHER EXPRESSED OR IMPLIED, OF MERCHANTABILITY, FITNESS FOR A PARTICULAR PURPOSE OR OF ANY OTHER NATURE ARE MADE HEREUNDER WITH RESPECT TO THE INFORMATION CONTAINED HEREIN.

SOLBERG® FOAM SYSTEM ACCESSORY VALVES

SWING CHECK VALVE

FEATURES

- **Metal-to-metal seal**
- **Stainless steel body**
- **Female threaded end connections**

DESCRIPTION

The SOLBERG® Swing Check Valve has a stainless steel disc for the internal movable part, which is on a hinge to block reverse flow. Swing Check Valves are available for use with most bladder tank foam systems. All valves are of stainless steel construction and have NPT connections with a maximum working pressure of 200 psi (14 bar). The Swing Check Valve prevents foam-water solution from draining through the existing fire sprinkler riser from a remote location, eliminating the need for personnel to go near or access concentrate piping and the foam tank assembly.

ORDERING INFORMATION

SWING CHECK VALVE		FACE TO FACE VALVE LENGTH		APPROXIMATE SHIPPING WEIGHT	
PART NO.	DESCRIPTION	in	mm	lb	kg
30400	Swing Check Valve, Stainless Steel, 1.0" NPT	3.54	89.91	1	0.5
30401	Swing Check Valve, Stainless Steel, 1.25" NPT	4.13	104.90	2	1
30402	Swing Check Valve, Stainless Steel, 1.5" NPT	4.72	119.88	3	1.5
30403	Swing Check Valve, Stainless Steel, 2.0" NPT	5.51	139.95	5	2
30404	Swing Check Valve, Stainless Steel, 2.5" NPT	6.08	154.43	9	4
30405	Swing Check Valve, Stainless Steel, 3.0" NPT	7.29	185.16	12	5



SOLBERG® FOAM SYSTEM ACCESSORY VALVES

WATER INLET & CONCENTRATE ISOLATION BALL VALVES

FEATURES

- Works with all SOLBERG foam concentrates
- Corrosion resistant material construction
- Easily identifiable open and closed positions

DESCRIPTION

Solberg offers Water Inlet and Concentrate Isolation Control Ball Valves for use with SOLBERG foam systems hardware. Both style valves are of stainless steel construction, RTFE seats, PTFE seals and NPT threaded connections. Water Inlet and Concentrate Isolation Control Ball Valves are supplied with nameplate, ring pin and chain to allow the valve to be visually monitored in an open or closed position.



ORDERING INFORMATION

WATER INLET & CONCENTRATE ISOLATION BALL VALVES		FACE TO FACE VALVE LENGTH		APPROXIMATE SHIPPING WEIGHT	
PART NO.	DESCRIPTION	in	mm	lb	kg
30410	Water Inlet Ball Valve, Stainless Steel, Threaded, 1.0", NPT	3.26	82.80	1	.5
30411	Water Inlet Ball Valve, Stainless Steel, Threaded, 1.25", NPT	3.82	97.02	1	.5
30412	Water Inlet Ball Valve, Stainless Steel, Threaded, 1.5", NPT	4.29	108.96	5	2
30413	Water Inlet Ball Valve, Stainless Steel, Threaded, 2.0", NPT	5.08	129.03	8	4
30414	Water Inlet Ball Valve, Stainless Steel, Threaded, 2.5", NPT	6.56	166.62	16	7
30415	Water Inlet Ball Valve, Stainless Steel, Threaded, 3.0", NPT	7.56	192.02	23	10
30420	Concentrate Isolation Ball Valve, Stainless Steel, Threaded, 1.0", NPT	3.26	82.80	1	.5
30421	Concentrate Isolation Ball Valve, Stainless Steel, Threaded, 1.25", NPT	3.82	97.02	1	.5
30422	Concentrate Isolation Ball Valve, Stainless Steel, Threaded, 1.5", NPT	4.29	108.96	5	2
30423	Concentrate Isolation Ball Valve, Stainless Steel, Threaded, 2.0", NPT	5.08	129.03	8	4
30424	Concentrate Isolation Ball Valve, Stainless Steel, Threaded, 2.5", NPT	6.56	166.62	16	7
30425	Concentrate Isolation Ball Valve, Stainless Steel, Threaded, 3.0", NPT	7.56	192.02	23	10

SOLBERG® FOAM SYSTEM ACCESSORY VALVES

PRESSURE REDUCING VALVE

FEATURES

- Rugged brass body
- Stainless steel stem and spring
- Oversized orifice
- Standard 0.125 in (3mm) gauge port (plugged)
- Slotted and knurled heavy duty adjusting screw

DESCRIPTION

The SOLBERG® mini Pressure Reducing Valve (PRV) is designed to reduce incoming water pressure to a sensible level to protect foam system components. The PRV is constructed with a brass body, stainless steel stem and spring, Buna-N seats and diaphragm. The maximum working pressure is 300 psi (21 bar) with a temperature range of 33°F - 140°F (0.5°C - 60°C). The PRV is placed in the sensing line between the hydraulic concentrate ball valve and the sprinkler actuating valve (alarm check, deluge, etc.) when the system water pressure will meet or exceed 160 psi (11 bar).

TYPICAL PIPING ISOMETRIC

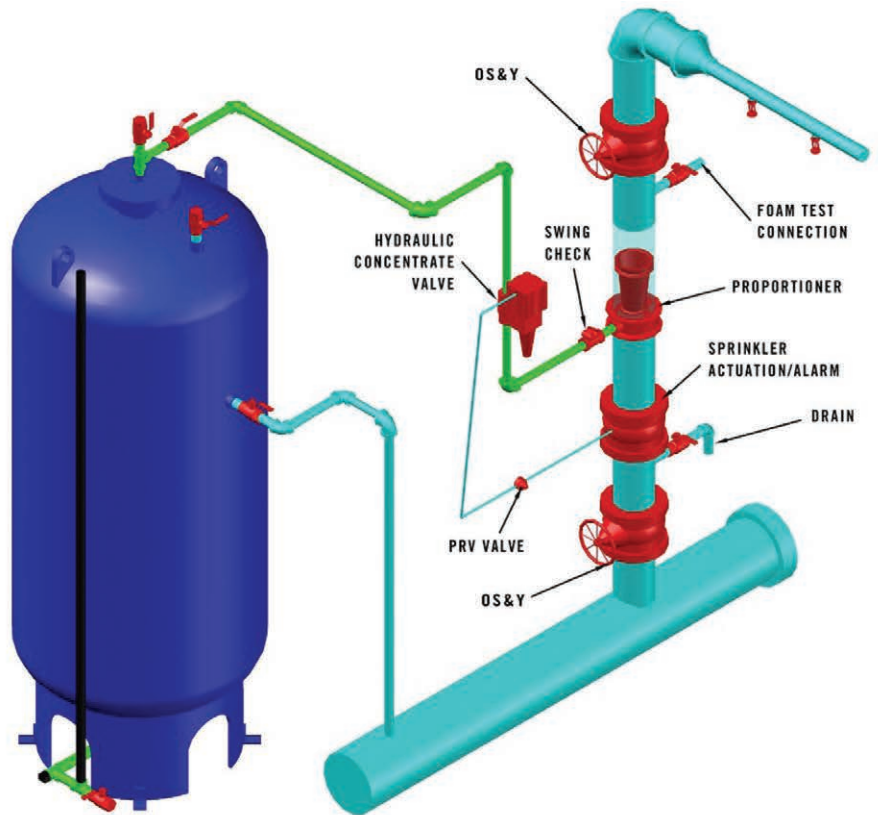

ORDERING INFORMATION

PRESSURE REDUCING VALVE		APPROXIMATE SHIPPING WEIGHT	
PART NO.	DESCRIPTION	lb	kg
30360	Pressure Reducing Valve, 0.25"	5	0.14



Solutions That Save.

FOR MORE INFORMATION

Contact any of our worldwide Perimeter Solutions Fire Safety offices or visit:

www.Perimeter-Solutions.com

UNITED STATES

10667 Jersey Blvd.
Rancho Cucamonga, CA 91730

Tel: +1 800 682 3626

Tel: +1 909 983 0772

salesfoamusa@perimeter-solutions.com

EMEA

Polígono de Baiña, Parcela 23
33682 Mieres (Asturias)

Spain

Tel: +34 985 24 29 45

salesfoamemea@perimeter-solutions.com

ASIA PACIFIC

3 Charles Street
St Marys NSW 2760 – Australia

Tel: +61 2 9673 5300

salesfoamapac@perimeter-solutions.com

perimeter-solutions.com

NOTICE PERIMETER SOLUTIONS MAKES NO REPRESENTATIONS OR WARRANTIES AS TO THE COMPLETENESS OR ACCURACY OF THE INFORMATION INCLUDED HEREIN. THE INFORMATION CONTAINED HEREIN IS NOT INTENDED TO PROVIDE REGULATORY, LEGAL OR EXPERT ADVICE RELATING TO THE PRODUCTS, ITS APPLICATION OR USES. NOTHING CONTAINED HEREIN IS TO BE CONSTRUED AS A RECOMMENDATION TO USE ANY PRODUCT, PROCESS, EQUIPMENT OR FORMULATION IN CONFLICT WITH ANY INDUSTRIAL PROPERTY OR INTELLECTUAL PROPERTY RIGHTS, AND PERIMETER SOLUTIONS MAKES NO REPRESENTATION OR WARRANTY, EXPRESS OR IMPLIED, THAT THE USE THEREOF WILL NOT INFRINGE ON ANY INDUSTRIAL PROPERTY OR INTELLECTUAL PROPERTY RIGHTS. NO REPRESENTATIONS OR WARRANTIES, EITHER EXPRESSED OR IMPLIED, OF MERCHANTABILITY, FITNESS FOR A PARTICULAR PURPOSE OR OF ANY OTHER NATURE ARE MADE HEREUNDER WITH RESPECT TO THE INFORMATION CONTAINED HEREIN.

SOLBERG® HYDRAULIC CONCENTRATE BALL VALVE

FEATURES

- **Completely self-contained unit**
- **Use with SOLBERG Fluoro-free, AFFF or Alcohol Type Concentrates (ATC™)**
- **Operates with water only**
- **Threaded or flange connection ends**

DESCRIPTION

SOLBERG® Hydraulic Concentrate Ball Valves come in standard sizes ranging from 1.0" to 2.5" (DN25-DN65) to match the concentrate inlet thread (or flange) size on SOLBERG Proportioners and Inline Balanced Pressure Proportioner (ILBP) assemblies.*

Each ball valve consists of a factory assembled and tested stainless steel or bronze ball valve, stainless steel hydraulic actuator, and mounting kit attaching the actuator to the ball valve. The actuator has a position indicator for manual reset.

The actuator's internal mechanisms are designed to be compatible for use with pressurized water, which is used as the means of actuation. To pressurize the actuator, a water line is commonly run from the alarm trim of the sprinkler valve.

For foam concentrate lines, the ball valve is in a normally closed position and is hydraulically opened for system use. Caution should be taken to ensure that the proper pressure sensing port is utilized on the actuator to drive the valve to the open position.

The hydraulic concentrate ball valve can be used with any type foam-water closed-head, sprinkler system (wet pipe, dry pipe, pre-action), as well as open head deluge systems.

Actuators are sized to operate the valve with a minimum pressure of 30 psi (2 bar). The pressure sensing line to the actuator should be a minimum 0.25" (6 mm) pipe or alternate 0.375" (9.5 mm) tubing (actual connection to the actuator is 0.125" NPT). Solberg Technical Services should be consulted for applications where the water pressure potential could be lower.

The maximum recommended water pressure to the actuator is 160 psi (11 bar). If potentially higher water pressures are encountered, an available 0.25" (6 mm) Pressure Reducing Valve (PRV) should be installed in the line to the actuator.

APPLICATION

The SOLBERG Hydraulic Concentrate Ball Valve is designed for use in either a SOLBERG bladder tank system or in an Inline Balanced Pressure Proportioning (ILBP) system.* The valve is used



to automatically open the line supplying foam concentrate to the foam proportioner and requires no electrical poweroperating solely by the pressure of the inlet water supply.

SPECIFICATIONS

The SOLBERG Hydraulic Concentrate Ball Valve shall consist of various hardware components that have been factory assembled and tested including:

- Stainless steel or bronze ball valve with mounting pad designed for a maximum of 600 psi (41 bar) Water Oil Gas (WOG).
- Ball valve shall be fitted with a stainless steel ball, stem and packing nut. Valve seats shall be of R PTFE material and stuffing box ring.
- Hydraulic actuator is approved by the manufacturer for using water as the medium to operate. The actuator shall have a position indicator and have the capability for manual override. The actuator shall be designed to operate the valve with a minimum of 30 psi (2 bar) and maximum 160 psi (11 bar) water pressure and shall contain no external moving parts which could cause fouling of adjacent equipment components, injury to personnel, misalignment
- The SOLBERG Hydraulic Concentrate Ball Valve is designed for use in either a SOLBERG bladder tank system or in an Inline Balanced Pressure Proportioning (ILBP) system*. The valve is used to automatically open the line supplying foam concentrate to the foam proportioner and requires no electrical poweroperating solely by the pressure of the inlet water supply. problems common to external linkage systems, or potential for disengagement caused by tampering.
- Mounting kit shall securely attach the hydraulic actuator to the ball valve.

CERTIFICATIONS

FM Approved per Approval Standard 5130 (*see FM Approval Guide).

SOLBERG® HYDRAULIC CONCENTRATE BALL VALVE

VALVE SIZE REQUIRED

PROPORTIONER SIZE	BLADDER TANK SYSTEM	PUMP SYSTEM (ILBP)
2.0" (DN50)	1.0" (DN25)	1.0" (DN25)
2.5" (DN65)	1.0" (DN25)	1.0" (DN25)
3.0" (DN80)	1.25" (DN32)	1.25" (DN32)
4.0" (DN100)	1.5" (DN40)	1.5" (DN40)
6.0" (DN150)	2.0" (DN50)	2.0" (DN50)
8.0" (DN200)	2.5" (DN65)	2.5" (DN65)

ORDERING INFORMATION

HYDRAULIC CONCENTRATE BALL VALVES		FACE TO FACE VALVE LENGTH		APPROXIMATE SHIPPING WEIGHT	
PART NO.	DESCRIPTION	in	mm	lb	kg
30330	Hydraulic Concentrate Ball Valve, Brass Threaded, 1.0" NPT	3.26	82.80	13	5
30331	Hydraulic Concentrate Ball Valve, Brass Threaded, 1.25" NPT	3.82	97.02	14	6
30332	Hydraulic Concentrate Ball Valve, Brass Threaded, 1.5" NPT	4.29	108.96	15	7
30333	Hydraulic Concentrate Ball Valve, Brass Threaded, 2.0" NPT	5.08	129.03	17	8
30334	Hydraulic Concentrate Ball Valve, Brass Threaded, 2.5" NPT	6.56	160.62	17	8
30335	Hydraulic Concentrate Ball Valve, Stainless Steel Flanged, 1.0" NPT	5.00	127.00	14	6
30336	Hydraulic Concentrate Ball Valve, Stainless Steel Flanged, 1.5" NPT	6.50	165.10	26	12
30337	Hydraulic Concentrate Ball Valve, Stainless Steel Flanged, 2.0" NPT	7.00	177.80	36	16
30338	Hydraulic Concentrate Ball Valve, Stainless Steel Flanged, 3.0" NPT†	7.99	203.00	85	39

† Not an FM Approved Component



Solutions That Save.

FOR MORE INFORMATION

Contact any of our worldwide Perimeter Solutions Fire Safety offices or visit:

www.Perimeter-Solutions.com

UNITED STATES

10667 Jersey Blvd.
Rancho Cucamonga, CA 91730
Tel: +1 800 682 3626
Tel: +1 909 983 0772
salesfoamusa@perimeter-solutions.com

EMEA

Polígono de Baiña, Parcela 23
33682 Mieres (Asturias)
Spain
Tel: +34 985 24 29 45
salesfoamemea@perimeter-solutions.com

ASIA PACIFIC

3 Charles Street
St Marys NSW 2760 – Australia
Tel: +61 2 9673 5300
salesfoamapac@perimeter-solutions.com

perimeter-solutions.com

NOTICE PERIMETER SOLUTIONS MAKES NO REPRESENTATIONS OR WARRANTIES AS TO THE COMPLETENESS OR ACCURACY OF THE INFORMATION INCLUDED HEREIN. THE INFORMATION CONTAINED HEREIN IS NOT INTENDED TO PROVIDE REGULATORY, LEGAL OR EXPERT ADVICE RELATING TO THE PRODUCTS, ITS APPLICATION OR USES. NOTHING CONTAINED HEREIN IS TO BE CONSTRUED AS A RECOMMENDATION TO USE ANY PRODUCT, PROCESS, EQUIPMENT OR FORMULATION IN CONFLICT WITH ANY INDUSTRIAL PROPERTY OR INTELLECTUAL PROPERTY RIGHTS, AND PERIMETER SOLUTIONS MAKES NO REPRESENTATION OR WARRANTY, EXPRESS OR IMPLIED, THAT THE USE THEREOF WILL NOT INFRINGE ON ANY INDUSTRIAL PROPERTY OR INTELLECTUAL PROPERTY RIGHTS. NO REPRESENTATIONS OR WARRANTIES, EITHER EXPRESSED OR IMPLIED, OF MERCHANTABILITY, FITNESS FOR A PARTICULAR PURPOSE OR OF ANY OTHER NATURE ARE MADE HEREUNDER WITH RESPECT TO THE INFORMATION CONTAINED HEREIN.

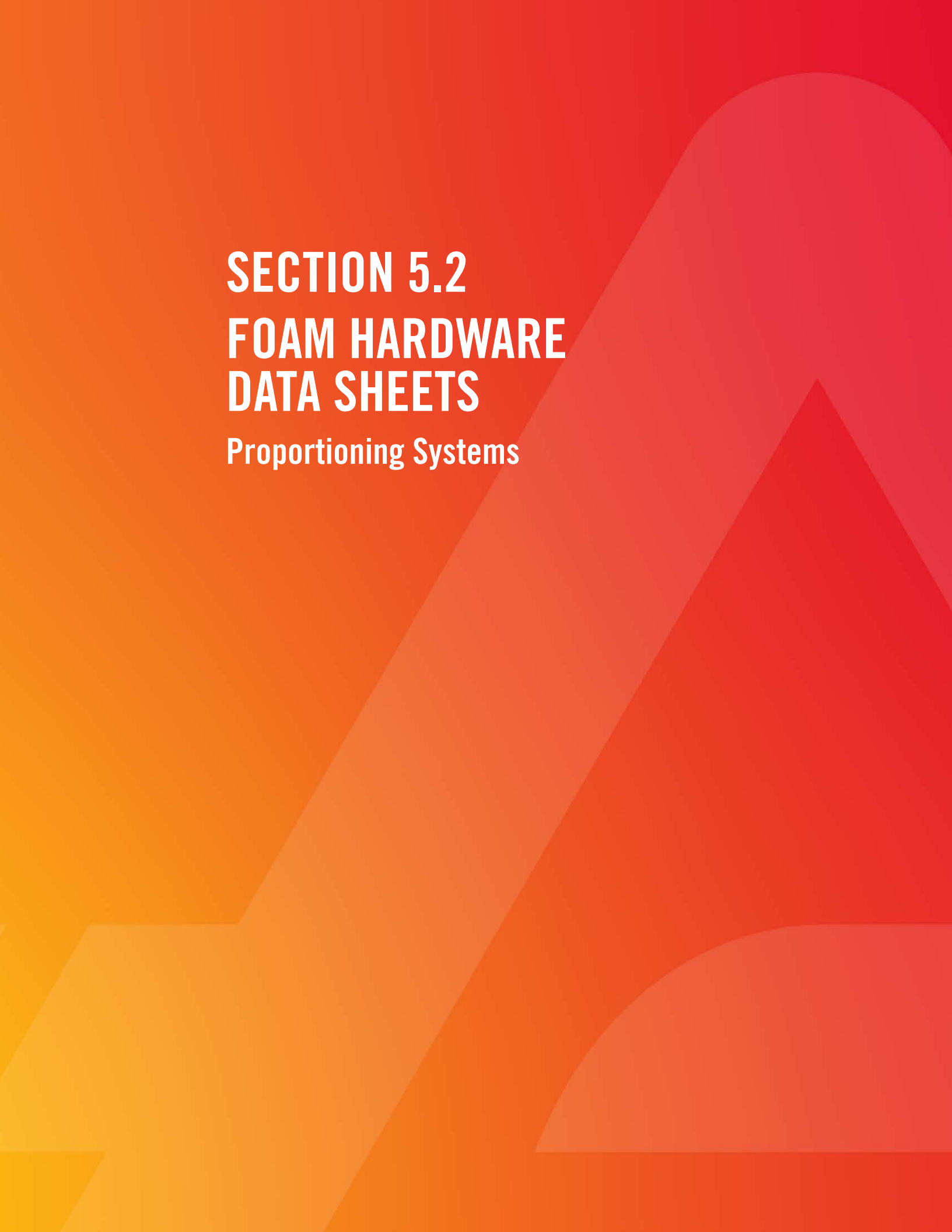

SECTION 5.2
FOAM HARDWARE
DATA SHEETS
Proportioning Systems

SOLBERG® IN-LINE BALANCE PRESSURE PROPORTIONERS

FEATURES

- All brass construction with duplex gauge
- Balancing valve to provide accurate proportioning over a wide range of flow rates
- UL listed with SOLBERG RE-HEALING™ RF3, 3% foam concentrate
- Six sizes available 3" - 8"

DESCRIPTION

The SOLBERG® In-line Balanced Pressure (ILBP) proportioner is a device that incorporates the necessary components including ratio controller, duplex gauge, balancing valve, check valve, ball valve, and associated brass piping. SOLBERG ILBPs are designed to balance the incoming foam concentrate pressure with the incoming fire-water pressure, and meter the correct amount of foam concentrate to fire-water stream over a wide range of flow rates and pressures. The ILBP system works with a positive displacement foam pump, to supply foam concentrate to the ILBP. A pressure sustaining valve, located in the return line, carries excess foam concentrate not needed by the device back to the atmospheric storage tank.

Consult your authorized Perimeter Solutions Distributor or Technical Services at the planning stage of your project for expert advice on determining the right foam equipment for your application.

APPLICATION

SOLBERG ILBPs are used with positive displacement foam concentrate pumps in applications requiring the proportioning of large quantities of foam to multiple discharge devices. Typical applications include aircraft hangars, tank farms, dike protection, foam-water sprinkler systems and remote location of risers.



Note: Shown with optional flange piping.

SPECIFICATIONS

The In-line Balanced Pressure proportioner assembly contains all components including ratio controller, duplex gauge, balancing valve, check valve, ball valve, and interconnecting brass piping. Balancing of foam concentrate pressure and systems water pressure is accomplished through the balancing valves are "Y" pattern diaphragm valves, stainless Steel body and cap with Buna N diaphragm material. The balancing valves come in the standard normally open configuration without any internal limit stop or springs. Correct balancing is accomplished through two sensing lines (foam-water system supply and foam concentrate line). Both lines are connected to the balancing valve and the duplex gauge which reports readings for the water and foam concentrate pressure.

Additional valves and gauges can be used with the ILBP assembly. It is recommended to use a concentrate isolation ball valve and swing check valve at the inlet to the ILBP assembly. Any additional components used with the ILBP should be made of materials compatible with Perimeter Solutions foam concentrates.

CERTIFICATION

ILBPs are UL Listed with the SOLBERG RE-HEALING 3% concentrate for the flow ranges listed below.

SOLBERG® IN-LINE BALANCE PRESSURE PROPORTIONERS

ORDERING INFORMATION

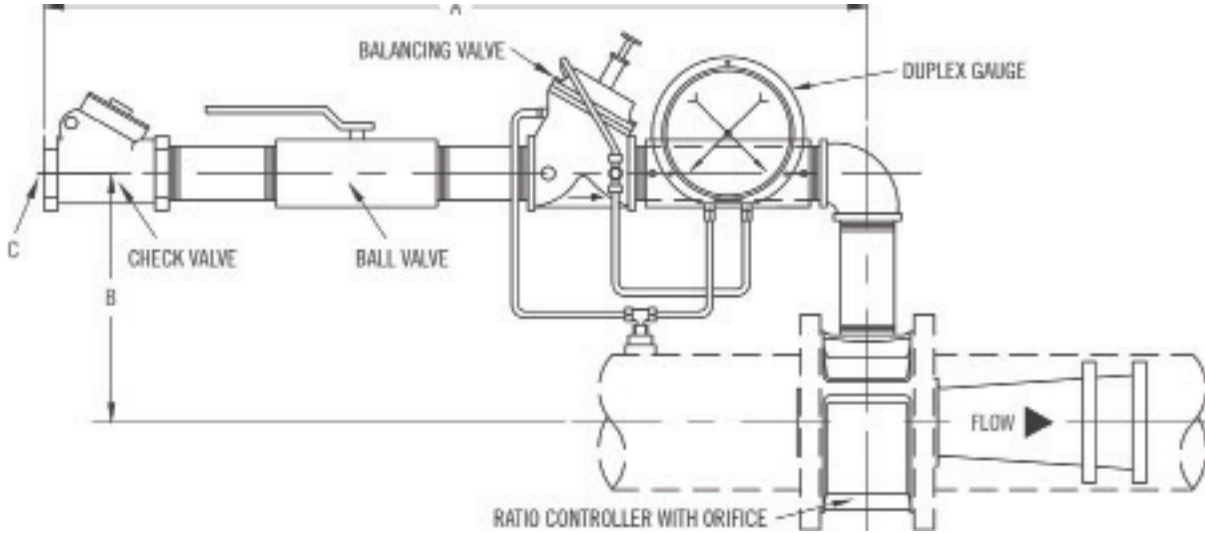

PERFORMANCE INFORMATION

APPROXIMATE DIMENSIONS Inches (Millimeters)			
MODEL	A	B	C
PS-ILBP-3-RF3	22.00 (559)	12.00 (305)	1.50 (38.10)
PS-ILBP-4-RF3	24.00 (610)	14.00 (357)	1.50 (38.10)
PS-ILBP-6-RF3	27.00 (686)	15.00 (381)	2.00 (50.80)
PS-ILBP-8-RF3	29.00 (737)	16.00 (406)	2.00 (50.80)

PART NO.	Model	Description	Listed Flow Range (GPM)
31101	PS-ILBP-3-RF3	3 inch In-Line Balanced Pressure Proportioner use with RF3	120 255 - 374
31102	PS-ILBP-4-RF3	4 inch In-Line Balanced Pressure Proportioner use with RF3	415 - 1200
31103	PS-ILBP-6-RF3	6 inch In-Line Balanced Pressure Proportioner use with RF3	1440 - 2220
31104	PS-ILBP-8-RF3	8 inch In-Line Balanced Pressure Proportioner use with RF3	875 - 4020

ORDERING INFORMATION

PART NO.	DESCRIPTION	APPROXIMATE SHIPPING WEIGHT	
		lb	kg
31101	3 inch In-Line Balanced Pressure Proportioner use with RF3	47	21
31102	4 inch In-Line Balanced Pressure Proportioner use with RF3	62	28
31103	6 inch In-Line Balanced Pressure Proportioner use with RF3	77	33
31104	8 inch In-Line Balanced Pressure Proportioner use with RF3	132	60



Solutions That Save.

FOR MORE INFORMATION

Contact any of our worldwide Perimeter Solutions Fire Safety offices or visit:

www.Perimeter-Solutions.com

UNITED STATES

10667 Jersey Blvd.
Rancho Cucamonga, CA 91730
Tel: +1 800 682 3626
Tel: +1 909 983 0772
salesfoamusa@perimeter-solutions.com

EMEA

Polígono de Baiña, Parcela 23
33682 Mieres (Asturias)
Spain
Tel: +34 985 24 29 45
salesfoamea@perimeter-solutions.com

ASIA PACIFIC

3 Charles Street
St Marys NSW 2760 – Australia
Tel: +61 2 9673 5300
salesfoamapac@perimeter-solutions.com

perimeter-solutions.com

NOTICE PERIMETER SOLUTIONS MAKES NO REPRESENTATIONS OR WARRANTIES AS TO THE COMPLETENESS OR ACCURACY OF THE INFORMATION INCLUDED HEREIN. THE INFORMATION CONTAINED HEREIN IS NOT INTENDED TO PROVIDE REGULATORY, LEGAL OR EXPERT ADVICE RELATING TO THE PRODUCTS, ITS APPLICATION OR USES. NOTHING CONTAINED HEREIN IS TO BE CONSTRUED AS A RECOMMENDATION TO USE ANY PRODUCT, PROCESS, EQUIPMENT OR FORMULATION IN CONFLICT WITH ANY INDUSTRIAL PROPERTY OR INTELLECTUAL PROPERTY RIGHTS, AND PERIMETER SOLUTIONS MAKES NO REPRESENTATION OR WARRANTY, EXPRESS OR IMPLIED, THAT THE USE THEREOF WILL NOT INFRINGE ON ANY INDUSTRIAL PROPERTY OR INTELLECTUAL PROPERTY RIGHTS. NO REPRESENTATIONS OR WARRANTIES, EITHER EXPRESSED OR IMPLIED, OF MERCHANTABILITY, FITNESS FOR A PARTICULAR PURPOSE OR OF ANY OTHER NATURE ARE MADE HEREUNDER WITH RESPECT TO THE INFORMATION CONTAINED HEREIN.

SOLBERG® FOAM RATIO CONTROLLER (Between Flange)



FEATURES

- Compatible with all type foam concentrates
- Fresh or saltwater use
- Proportions at 1%, 3% or 6%
- Vertical or horizontal position for installation versatility
- Bronze construction for durability and performance

DESCRIPTION

SOLBERG® Ratio Controllers are modified venturi devices designed to meter the correct amount of foam concentrate into a water stream over a specified range of flow and pressure rates with minimal pressure loss. The ratio controller consists of three components: the body with water inlet, metering orifice located in the foam concentrate inlet, and throat (nozzle) located downstream from the water inlet. The ratio controller is manufactured in four sizes 3.0", 4.0", 6.0" and 8.0" (76 mm, 102 mm, 152 mm, 203 mm).

Application

SOLBERG Ratio Controllers are commonly used in bladder tank systems, balanced or inline balanced* pressure proportioning systems for aircraft hangars, loading racks, tank farms, and foam-water sprinkler systems.

Specifications

The SOLBERG Ratio Controller is designed for installation between two Class 150 flanges of the same nominal size as the ratio controller. The components are constructed of ASTM 85-5-5-5 bronze and the inlet is tapered and machined to a smooth



finish to maximize water stream efficiency. The inlet nozzle and metering orifice are secured by a stainless steel retaining ring. The foam concentrate inlet has a female NPT thread and contains a foam concentrate metering orifice to proportion over the specified flow range without any manual adjustment. The SOLBERG Foam Ratio Controller is to be installed with a minimum of 5 pipe diameters of straight pipe both upstream and downstream of the proportioner.

CERTIFICATIONS

Underwriters Laboratories, Inc. (UL) Listed – Standard 162, FM Approved per Approval Standard 5130.

*Not an FM Approved Configuration

SOLBERG® FOAM RATIO CONTROLLER (Between Flange)

DIMENSIONAL INFORMATION

MODEL	APPROXIMATE DIMENSIONS Inches (Millimeters)						STANDARD CONCENTRATE LINE SIZES
	A	B	C	D	E	F	
3.0" SRCW	1.25 (32)	2.38 (60)	2.63 (67)	1.25 (32)	3.75 (95)	6.13 (156)	1.25
4.0" SRCW	1.50 (38)	2.63 (67)	3.38 (86)	1.31 (33)	5.38 (137)	8.00 (203)	1.50
6.0" SRCW	2.00 (51)	3.25 (83)	4.25 (108)	1.63 (41)	8.75 (222)	12.00 (305)	2.00
8.0" SRCW	2.50 (64)	3.50 (89)	5.25 (133)	1.75 (44)	8.50 (216)	12.00 (305)	2.50

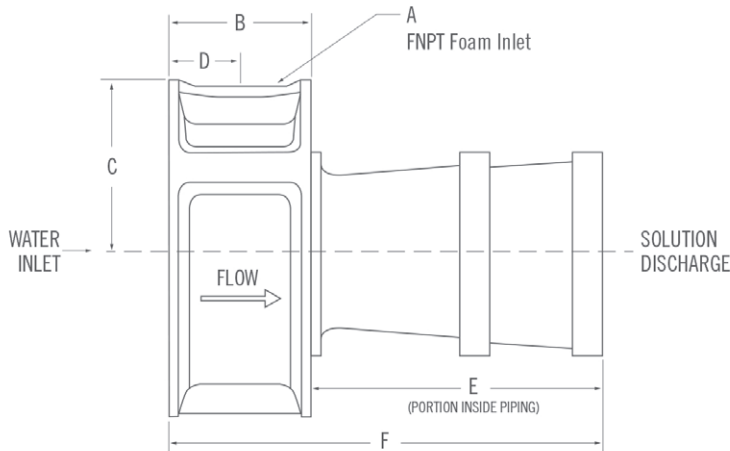

Note: 1%, 3% or 6% proportioning and type of foam concentrate to be specified by customer.

FLOW RANGE

UL LISTED - NOMINAL FLOW

MODEL	CONFIGURATION	SOLBERG RE-HEALING RF3, 3% gpm (lpm)	SOLBERG ARCTIC 1% SP AFFF gpm (lpm)	SOLBERG ARCTIC 3% AFFF gpm (lpm)"	SOLBERG ARCTIC 3% MIL-SPEC AFFF gpm (lpm)"	SOLBERG ARCTIC 3x3% ATC gpm (lpm)"
3.0" SRCW	Between Flange	423-689 (1601-2608)	78-736 (295-2786)	93-768 (352-2907)	96-550 (363-2082)	206-812 (780-3074)
4.0" SRCW	Between Flange	752-1257 (2847-4758)	140-1360 (530-5148)	207-1532 (784-5799)	210-1335 (795-5053)	329-1530 (1245-5792)
4.0" SRCW	Between Flange	595-1335 (2252-5054)	-	-	-	-
6.0" SRCW	Between Flange	1019-1845 (3857-6984)	388-2830 (1469-10713)	318-2680 (1204-10145)	295-2250 (1117-8516)	736-2667 (2786-10096)
6.0" SRCW	Between Flange	1564-2027 (5920-7673)	-	-	-	-
8.0" SRCW	Between Flange	1909-4718 (7223-17860)	630-4920 (2385-18624)	975-4355 (3691-16485)	975-4250 (3690-16086)	1670-4590 (6322-17375)

FM APPROVED - NOMINAL FLOW

MODEL	CONFIGURATION	SOLBERG RE-HEALING RF3, 3% gpm (lpm)	SOLBERG RE-HEALING RF3, 3% gpm (lpm)
3.0" SRCW	Between Flange	490-665 (1855-2517)	206-785 (780-2971)
4.0" SRCW	Between Flange	700-1215 (2650-4600)	238-1153 (900-4365)
6.0" SRCW	Between Flange	1310-1955 (4960-7552)	730-2245 (2763-8498)

SOLBERG® FOAM RATIO CONTROLLER (Between Flange)

PRESSURE LOSS CURVES

NOMINAL FLOW RATES

UL LISTED NOMINAL FLOW RATES

RE-HEALING RF3, 3% FOAM CONCENTRATE

3 Inch Ratio Controller

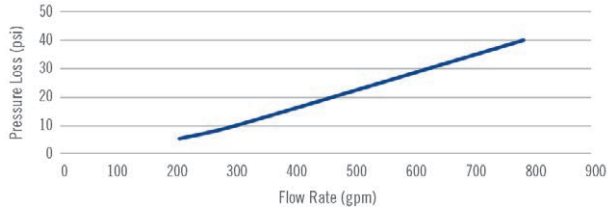

4 Inch Ratio Controller

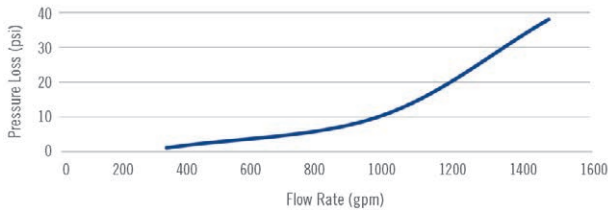

6 Inch Ratio Controller

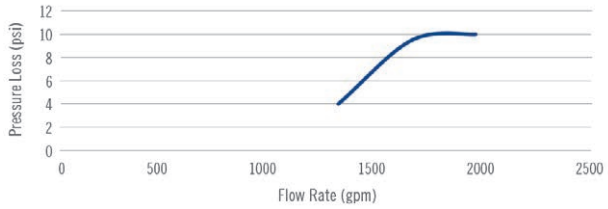

8 Inch Ratio Controller

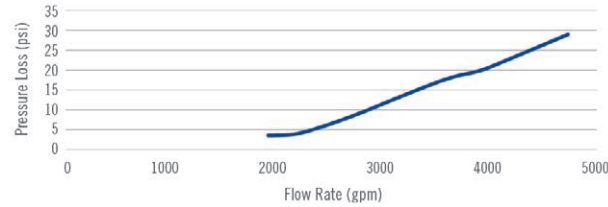

UL LISTED NOMINAL FLOW RATES

ARCTIC™ 1% SP FOAM CONCENTRATE

3 Inch Ratio Controller

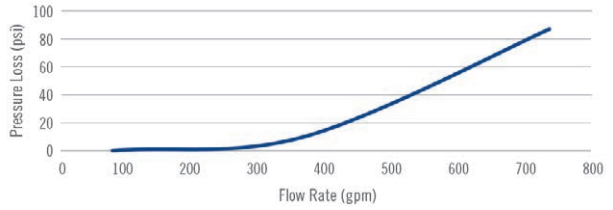

4 Inch Ratio Controller

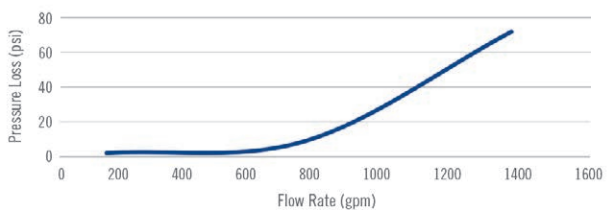

6 Inch Ratio Controller

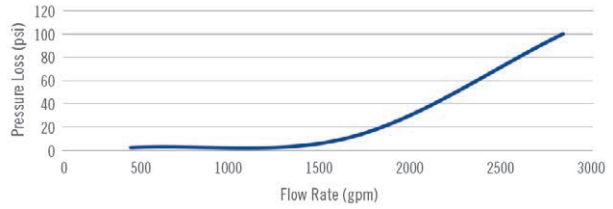

8 Inch Ratio Controller

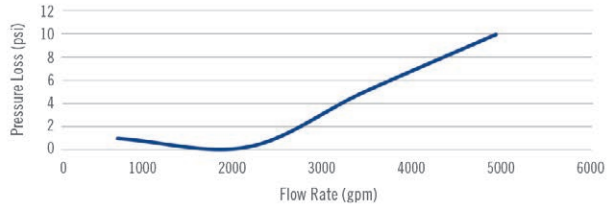

SOLBERG® FOAM RATIO CONTROLLER (Between Flange)

PRESSURE LOSS CURVES

NOMINAL FLOW RATES

UL LISTED NOMINAL FLOW RATES

ARCTIC™ 1% AFFF FOAM CONCENTRATE

3 Inch Ratio Controller

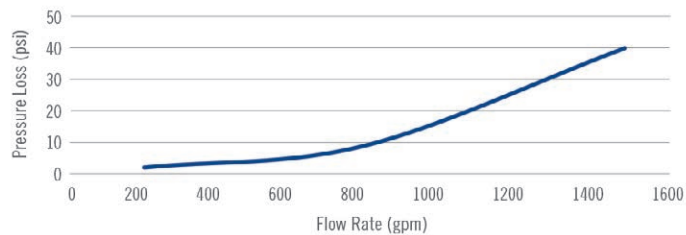

4 Inch Ratio Controller

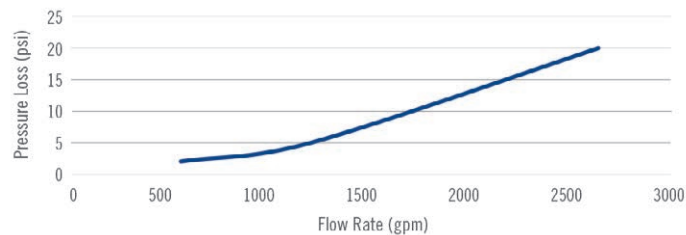

UL LISTED NOMINAL FLOW RATES

ARCTIC™ 3% AFFF FOAM CONCENTRATE

3 Inch Ratio Controller

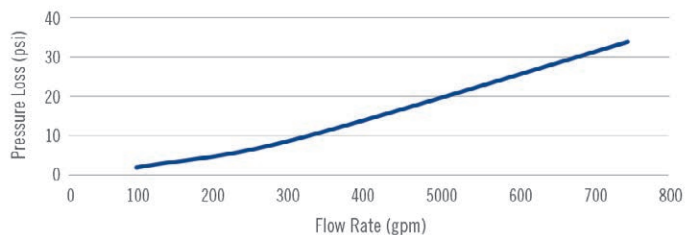

4 Inch Ratio Controller

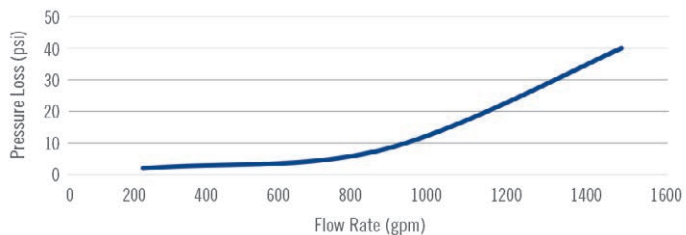

6 Inch Ratio Controller

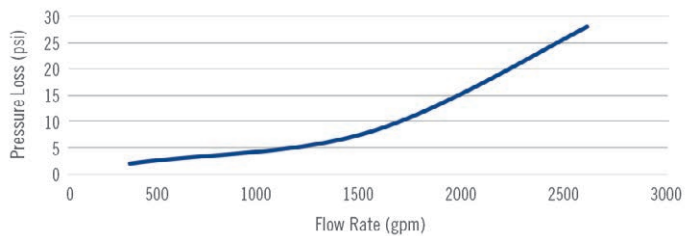

8 Inch Ratio Controller

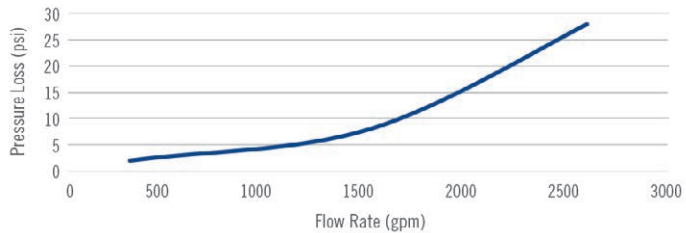

SOLBERG® FOAM RATIO CONTROLLER (Between Flange)

PRESSURE LOSS CURVES

NOMINAL FLOW RATES

UL LISTED NOMINAL FLOW RATES

ARCTIC™ 3% MIL-SPEC FOAM CONCENTRATE

3 Inch Ratio Controller

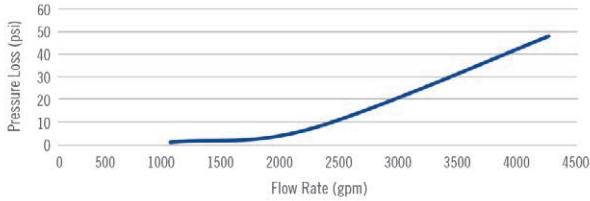

4 Inch Ratio Controller

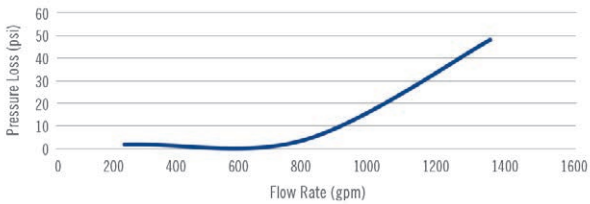

6 Inch Ratio Controller

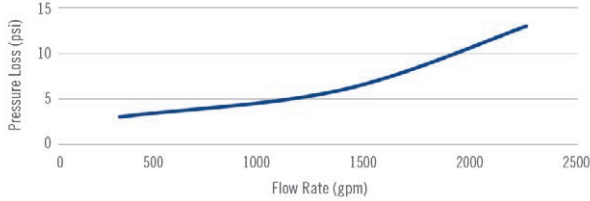

8 Inch Ratio Controller

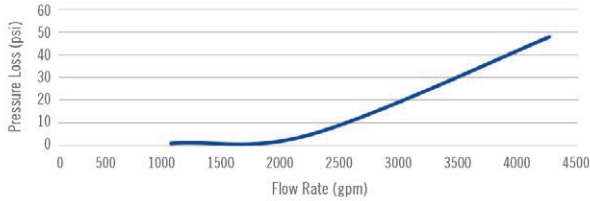

UL LISTED NOMINAL FLOW RATES

ARCTIC™ 3X3% ATC™ FOAM CONCENTRATE

3 Inch Ratio Controller

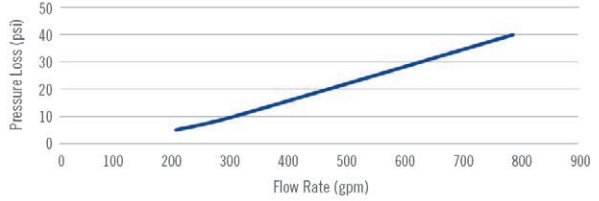

4 Inch Ratio Controller

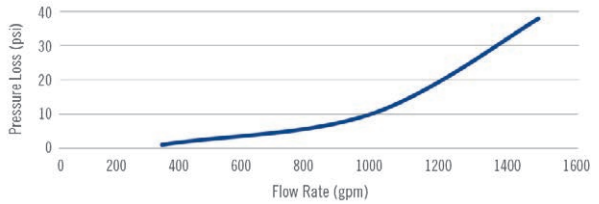

6 Inch Ratio Controller

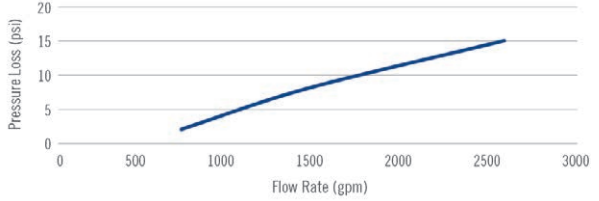

8 Inch Ratio Controller

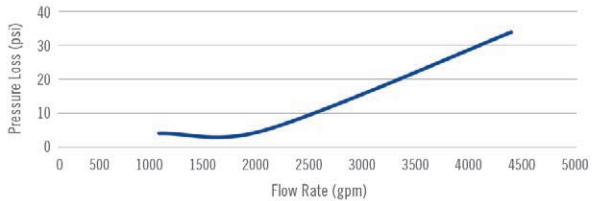

SOLBERG® FOAM RATIO CONTROLLER (Between Flange)

PRESSURE LOSS CURVES

NOMINAL FLOW RATES

FM APPROVED NOMINAL FLOW RATES

RE-HEALING RF3, 3% FOAM CONCENTRATE

3 Inch Ratio Controller

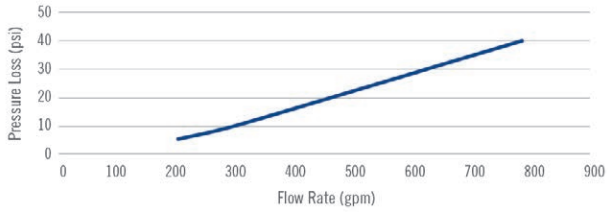

4 Inch Ratio Controller

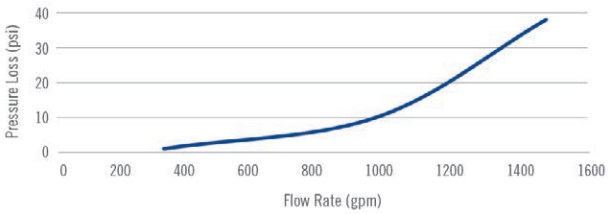

6 Inch Ratio Controller

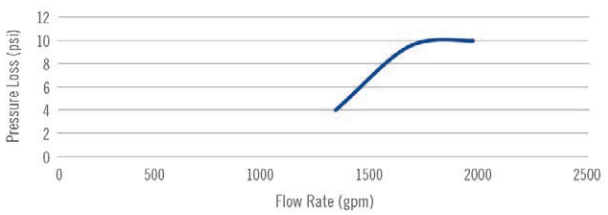

FM APPROVED NOMINAL FLOW RATES

ARCTIC™ 3X3% ATC™ FOAM CONCENTRATE

3 Inch Ratio Controller

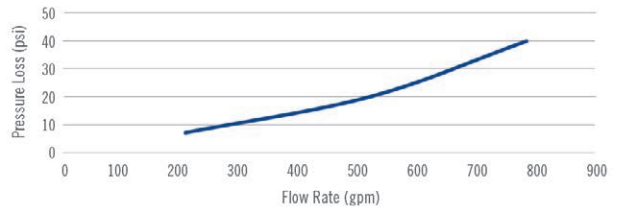

4 Inch Ratio Controller

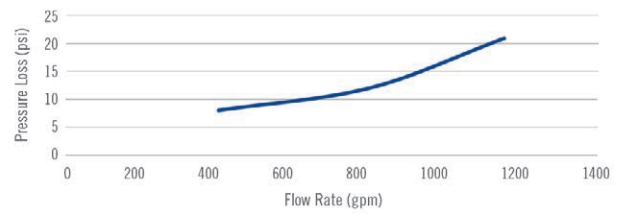

6 Inch Ratio Controller

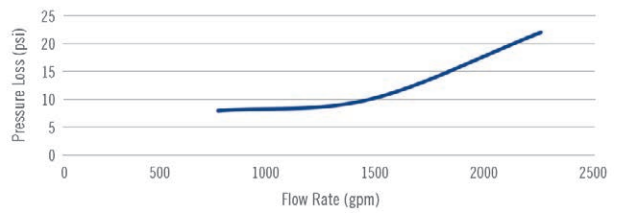

SOLBERG® FOAM RATIO CONTROLLER (Between Flange)

ORDERING INFORMATION

RATIO CONTROLLERS / BETWEEN FLANGE		APPROXIMATE SHIPPING WEIGHT	
PART NO.	DESCRIPTION	lb	kg
30104	Ratio Controller - Between Flange, 3.0" (76 mm), SOLBERG RE-HEALING RF3, 3%	10	4
30108	Ratio Controller - Between Flange, 3.0" (76 mm), SOLBERG RE-HEALING RF6, 6%	10	4
30112	Ratio Controller - Between Flange, 3.0" (76 mm), SOLBERG HIGH-EXPANSION	10	4
30120	Ratio Controller - Between Flange, 3.0" (76 mm), SOLBERG ARCTIC 1% SP AFFF	10	4
30121	Ratio Controller - Between Flange, 3.0" (76 mm), SOLBERG ARCTIC 3% AFFF	10	4
30123	Ratio Controller - Between Flange, 3.0" (76 mm), SOLBERG ARCTIC 3% MIL-SPEC AFFF	10	4
30122	Ratio Controller - Between Flange, 3.0" (76 mm), SOLBERG ARCTIC 3x3% ATC	10	4
30105	Ratio Controller - Between Flange, 4.0" (102 mm), SOLBERG RE-HEALING RF3, 3%	16	7
30109	Ratio Controller - Between Flange, 4.0" (102 mm), SOLBERG RE-HEALING RF6, 6%	16	7
30113	Ratio Controller - Between Flange, 4.0" (102 mm), SOLBERG HIGH-EXPANSION	16	7
30130	Ratio Controller - Between Flange, 4.0" (102 mm), SOLBERG ARCTIC 1% AFFF	16	7
30134	Ratio Controller - Between Flange, 4.0" (102 mm), SOLBERG ARCTIC 1% SP AFFF	16	7
30131	Ratio Controller - Between Flange, 4.0" (102 mm), SOLBERG ARCTIC 3% AFFF	16	7
30133	Ratio Controller - Between Flange, 4.0" (102 mm), SOLBERG ARCTIC 3% MIL-SPEC AFFF	16	7
30132	Ratio Controller - Between Flange, 4.0" (102 mm), SOLBERG ARCTIC 3x3% ATC	16	7
30106	Ratio Controller - Between Flange, 6.0" (152 mm), SOLBERG RE-HEALING RF3, 3%	32	14
30110	Ratio Controller - Between Flange, 6.0" (152 mm), SOLBERG RE-HEALING RF6, 6%	32	14
30114	Ratio Controller - Between Flange, 6.0" (152 mm), SOLBERG HIGH-EXPANSION	32	14
30140	Ratio Controller - Between Flange, 6.0" (152 mm), SOLBERG ARCTIC 1% AFFF	32	14
30144	Ratio Controller - Between Flange, 6.0" (152 mm), SOLBERG ARCTIC 1% SP AFFF	32	14
30141	Ratio Controller - Between Flange, 6.0" (152 mm), SOLBERG ARCTIC 3% AFFF	32	14
30143	Ratio Controller - Between Flange, 6.0" (152 mm), SOLBERG ARCTIC 3% MIL-SPEC AFFF	32	14
30142	Ratio Controller - Between Flange, 6.0" (152 mm), SOLBERG ARCTIC 3x3% ATC	32	14
30107	Ratio Controller - Between Flange, 8.0" (203 mm), SOLBERG RE-HEALING RF3, 3%	53	24
30111	Ratio Controller - Between Flange, 8.0" (203 mm), SOLBERG RE-HEALING RF6, 6%	53	24
30115	Ratio Controller - Between Flange, 8.0" (203 mm), SOLBERG HIGH-EXPANSION	53	24
30150	Ratio Controller - Between Flange, 8.0" (203 mm), SOLBERG ARCTIC 1% SP AFFF	53	24
30151	Ratio Controller - Between Flange, 8.0" (203 mm), SOLBERG ARCTIC 3% AFFF	53	24
30153	Ratio Controller - Between Flange, 8.0" (203 mm), SOLBERG ARCTIC 3% MIL-SPEC AFFF	53	24
30152	Ratio Controller - Between Flange, 8.0" (203 mm), SOLBERG ARCTIC 3x3% ATC	53	24



Solutions That Save.

FOR MORE INFORMATION

Contact any of our worldwide Perimeter Solutions Fire Safety offices or visit:

www.Perimeter-Solutions.com

UNITED STATES

10667 Jersey Blvd.
Rancho Cucamonga, CA 91730
Tel: +1 800 682 3626
Tel: +1 909 983 0772
salesfoamusa@perimeter-solutions.com

EMEA

Polígono Industrial de Baiña, Parcela 23
33682 Baiña-Mieres (Asturias) – Spain
Tel: +34 985 24 29 45
salesfoameema@perimeter-solutions.com

ASIA PACIFIC

3 Charles Street
St Marys NSW 2760 – Australia
Tel: +61 2 9673 5300
salesfoamapac@perimeter-solutions.com

perimeter-solutions.com

NOTICE PERIMETER SOLUTIONS MAKES NO REPRESENTATIONS OR WARRANTIES AS TO THE COMPLETENESS OR ACCURACY OF THE INFORMATION INCLUDED HEREIN. THE INFORMATION CONTAINED HEREIN IS NOT INTENDED TO PROVIDE REGULATORY, LEGAL OR EXPERT ADVICE RELATING TO THE PRODUCTS, ITS APPLICATION OR USES. NOTHING CONTAINED HEREIN IS TO BE CONSTRUED AS A RECOMMENDATION TO USE ANY PRODUCT, PROCESS, EQUIPMENT OR FORMULATION IN CONFLICT WITH ANY INDUSTRIAL PROPERTY OR INTELLECTUAL PROPERTY RIGHTS, AND PERIMETER SOLUTIONS MAKES NO REPRESENTATION OR WARRANTY, EXPRESS OR IMPLIED, THAT THE USE THEREOF WILL NOT INFRINGE ON ANY INDUSTRIAL PROPERTY OR INTELLECTUAL PROPERTY RIGHTS. NO REPRESENTATIONS OR WARRANTIES, EITHER EXPRESSED OR IMPLIED, OF MERCHANTABILITY, FITNESS FOR A PARTICULAR PURPOSE OR OF ANY OTHER NATURE ARE MADE HEREUNDER WITH RESPECT TO THE INFORMATION CONTAINED HEREIN.

THREADED PROPORTIONER

FEATURES

- **Bronze material construction for performance and durability**
- **Fresh or saltwater compatible**
- **Horizontal or vertical mounted position**

DESCRIPTION

Perimeter Solutions Threaded Proportioners are modified venturi ratio controllers that accurately mix and meter

foam concentrate into fire-water streams. Each proportioner consists of the following components: body, inlet nozzle, and metering orifice constructed out of ASTM 85-5-5-5 bronze material. The proportioner is designed with a male NPT threaded inlet and a male threaded outlet in sizes of 2.0" and 2.5", with the flow direction arrow clearly marked. During operation, water flows through the modified venturi to create an area of lower pressure which is directly effected by the water velocity as it flows through the ratio controller.

APPLICATION

Typical high-hazard, high-risk applications including flammable liquid storage tanks, loading racks, aircraft hangars, heliports and anywhere flammable liquids are used, stored, processed, or transported.

You can count on Perimeter Solutions Threaded Proportioners to correctly proportion and properly handle the mixing of SOLBERG foam concentrates into a water stream with little pressure loss. SOLBERG Threaded Proportioners are UL listed when used with Solberg foam concentrates and can be used with bladder tank systems and inline balanced pressure proportioning systems.



SPECIFICATIONS

Each Perimeter Solutions Threaded Proportioners body and inlet nozzle is made of bronze with the inlet nozzle and orifice being secured by a stainless retaining ring. The inlet and outlet of the proportioner body is to be a male NPT with clear markings indicating flow direction and concentrate type. The inlet nozzle is designed with a rounded inlet and a smooth machined finish to ensure minimum stream constriction and maximum velocity. The metering orifice is designed to the proper diameter for the specific foam concentrate type.

CERTIFICATIONS

Underwriters Laboratories, Inc. (UL) Listed - Standard 162, FM Approved per Approval Standard 5130 (see FM Approval Guide).

THREADED PROPORTIONER

DIMENSIONAL INFORMATION

APPROXIMATE DIMENSIONS Inches (Millimeters)

MODEL	A	B	C	D	E
2.0" SRCW	2.38 (60)	7.00 (178)	2.06 (52)	3.75 (95)	10.00 (254)
2.5" SRCW	2.88 (73)	7.00 (178)	2.06 (52)	4.13 (105)	13.00 (330)

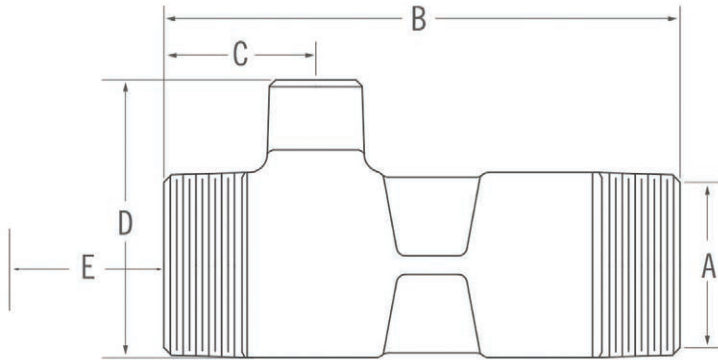

FLOW RANGE

UL LISTED - NOMINAL FLOW

MODEL	CONFIGURATION	CONCENTRATE INLET	RE-HEALING RF3,3% gpm (lpm)	ARCTIC 1% SP AFFF gpm (lpm)	ARCTIC 3% AFFF gpm (lpm)	ARCTIC 3% MIL-SPEC AFFF gpm (lpm)	ARCTIC 3X3%ATC gpm (lpm)
2.0" SRCW	Threaded	1.0" FNPT	147-232 (556-878)	44-131 (167-496)	42-263 (159-996)	45-205 (170-776)	90-166 (341-628)
2.0" SRCW	Threaded	1.0" FNPT	60 (227)	-	-	-	13.00 (330)
2.5" SRCW	Threaded	1.0" FNPT	-	86-282 (326-1067)	119-392 (450-1484)	114-375 (432-1420)	-

FM APPROVED - NOMINAL FLOW

MODEL	CONFIGURATION	CONCENTRATE INLET	RE-HEALING RF3,3% gpm (lpm)	ARCTIC 1% SP AFFF gpm (lpm)	ARCTIC 3% AFFF gpm (lpm)
2.0" SRCW	Threaded	1.0" FNPT	143-248 (541-939)	44-131 (167-496)	89-233 (337-882)

THREADED PROPORTIONER

PRESSURE LOSS CURVES

NOMINAL FLOW RATES

UL LISTED
RE-HEALING RF3, 3% FOAM CONCENTRATE

2 Inch Ratio Controller

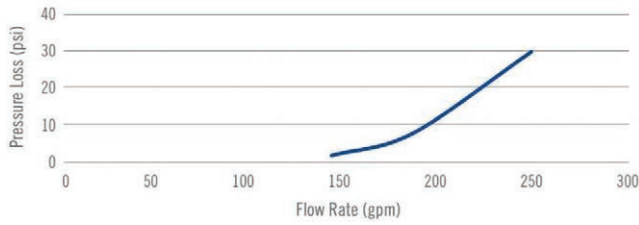

UL LISTED
ARCTIC™ 3% AFFF FOAM CONCENTRATE

2 Inch Ratio Controller

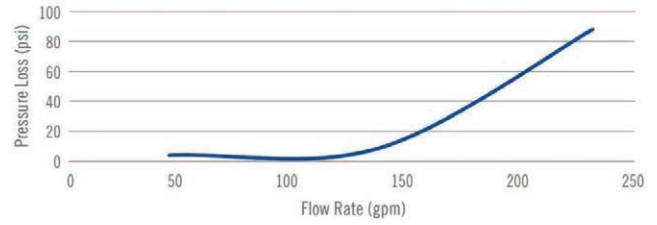

2.5 Inch Ratio Controller

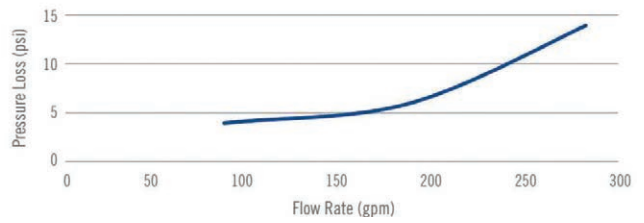

UL LISTED
ARCTIC™ 3% AFFF FOAM CONCENTRATE

2 Inch Ratio Controller

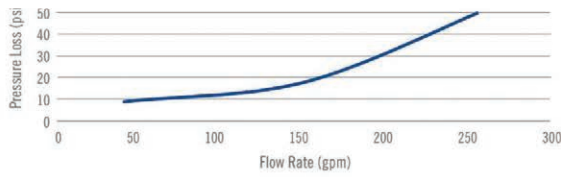

UL LISTED
ARCTIC™ 3% MIL-SPEC FOAM CONCENTRATE

2 Inch Ratio Controller

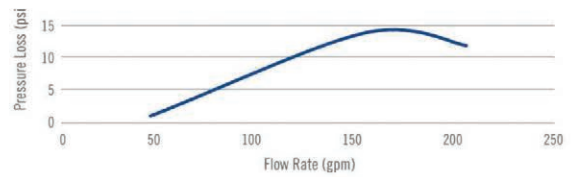

2.5 Inch Ratio Controller

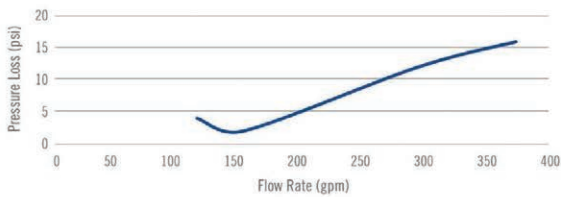

2.5 Inch Ratio Controller

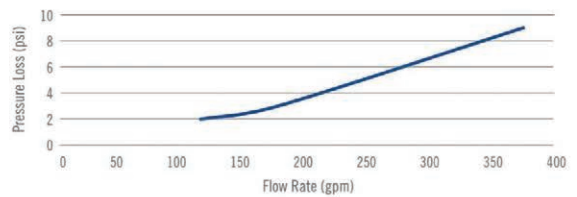

THREADED PROPORTIONER

PRESSURE LOSS CURVES

NOMINAL FLOW RATES

UL LISTED: ARCTIC™ 3X3% ATC™ FOAM CONCENTRATE

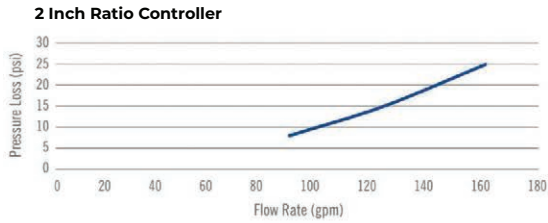

FM APPROVED: RE-HEALING RF3, 3% FOAM CONCENTRATE

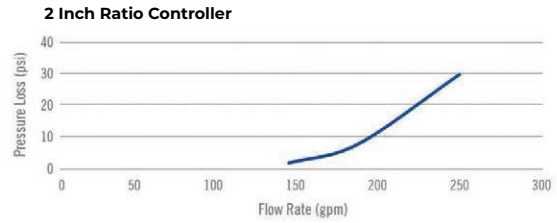

FM APPROVED: ARCTIC™ 3X3% ATC™ FOAM CONCENTRATE

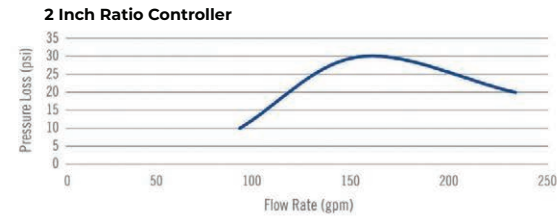
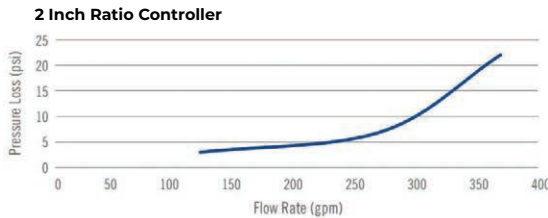

ORDERING INFORMATION

MOBILE FOAM CART

APPROXIMATE SHIPPING WEIGHT

PART NO.	DESCRIPTION	lb	kg
30002	Ratio Controller - Threaded, 2.0" (51 mm), RE-HEALING RF 3, 3%	5	2
30003	Ratio Controller - Threaded, 2.0" (51 mm), RE-HEALING RF 6, 6%	5	2
30004	Ratio Controller - Threaded, 2.0" (51 mm), ARCTIC 1% SP AFFF	5	2
30005	Ratio Controller - Threaded, 2.0" (51 mm), ARCTIC 3% AFFF	5	2
30008	Ratio Controller - Threaded, 2.0" (51 mm), ARCTIC 3% MIL-SPEC AFFF	5	2
30006	Ratio Controller - Threaded, 2.0" (51 mm), ARCTIC 3x3% ATC	5	2
30031	Ratio Controller - Threaded, 2.5" (63 mm), RE-HEALING RF 3, 3%	6	3
30032	Ratio Controller - Threaded, 2.5" (63 mm), RE-HEALING RF 6, 6%	6	3
30033	Ratio Controller - Threaded, 2.5" (63 mm), ARCTIC 1% SP AFFF	6	3
30034	Ratio Controller - Threaded, 2.5" (63 mm), ARCTIC 3% AFFF	6	3
30037	Ratio Controller - Threaded, 2.5" (63 mm), ARCTIC 3% MIL-SPEC AFFF	6	3
30035	Ratio Controller - Threaded, 2.5" (63 mm), ARCTIC 3x3% ATC	6	3



Solutions That Save.

FOR MORE INFORMATION

Contact any of our worldwide Perimeter Solutions Fire Safety offices or visit:

www.Perimeter-Solutions.com

UNITED STATES

10667 Jersey Blvd.
Rancho Cucamonga, CA 91730
Tel: +1 800 682 3626
Tel: +1 909 983 0772

salesfoamusa@perimeter-solutions.com

EMEA

Polígono de Baiña, Parcela 23
33682 Mieres (Asturias)
Spain
Tel: +34 985 24 29 45

salesfoamemea@perimeter-solutions.com

ASIA PACIFIC

3 Charles Street
St Marys NSW 2760 – Australia
Tel: +61 2 9673 5300

salesfoamapac@perimeter-solutions.com

perimeter-solutions.com

NOTICE PERIMETER SOLUTIONS MAKES NO REPRESENTATIONS OR WARRANTIES AS TO THE COMPLETENESS OR ACCURACY OF THE INFORMATION INCLUDED HEREIN. THE INFORMATION CONTAINED HEREIN IS NOT INTENDED TO PROVIDE REGULATORY, LEGAL OR EXPERT ADVICE RELATING TO THE PRODUCTS, ITS APPLICATION OR USES. NOTHING CONTAINED HEREIN IS TO BE CONSTRUED AS A RECOMMENDATION TO USE ANY PRODUCT, PROCESS, EQUIPMENT OR FORMULATION IN CONFLICT WITH ANY INDUSTRIAL PROPERTY OR INTELLECTUAL PROPERTY RIGHTS, AND PERIMETER SOLUTIONS MAKES NO REPRESENTATION OR WARRANTY, EXPRESS OR IMPLIED, THAT THE USE THEREOF WILL NOT INFRINGE ON ANY INDUSTRIAL PROPERTY OR INTELLECTUAL PROPERTY RIGHTS. NO REPRESENTATIONS OR WARRANTIES, EITHER EXPRESSED OR IMPLIED, OF MERCHANTABILITY, FITNESS FOR A PARTICULAR PURPOSE OR OF ANY OTHER NATURE ARE MADE HEREUNDER WITH RESPECT TO THE INFORMATION CONTAINED HEREIN.

VARIABLE RANGE PROPORTIONER

FEATURES

- FM Approved with RE-HEALING RF3, 3% and ARCTIC 3x3% ATC Foam Concentrates
- UL Listed with RE-HEALING RF3, 3%, ARCTIC 3% AFFF and ARCTIC 3x3% ATC Foam Concentrates
- Bronze and stainless steel material construction for performance and durability
- Fresh, salt and brackish water compatible
- Horizontal or vertical mounted position

DESCRIPTION

The Perimeter Solutions Variable Range Proportioner is a low foam solution proportioning device, designed to accurately proportion the foam concentrate into the water stream at both high and low system flow rates. The Perimeter Solutions Variable Range Proportioner is designed as an integral component of the Perimeter Solutions Bladder Tank proportioning system, to be used with SOLBERG foam concentrates in foam-water systems.

The Perimeter Solutions Variable Range Proportioner complies with NFPA 30, the Flammable and Combustible Liquids Code, Paragraph 16.5.1.6.2, which states that foam/water sprinkler systems are to provide foam solution to operating sprinklers with 4 sprinklers flowing. The Perimeter Solutions Variable Range Proportioner was designed to meet this Code requirement.

APPLICATION

The Perimeter Solutions Variable Range Proportioner is designed for closed-head foam-water sprinkler systems where proportioning of foam concentrate will begin at low flow rates, but as additional sprinklers operate, the proportioner will automatically adjust for the changes in system flow rates and

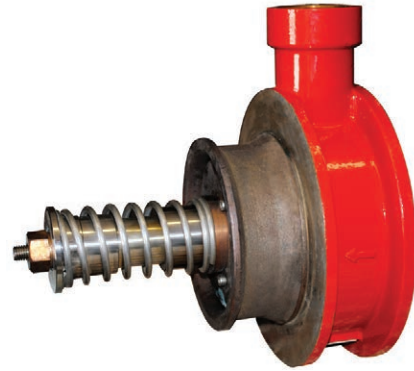

maintain accurate foam concentrate proportioning. Considering that the fire data shows that only 4 to 5 sprinklers will be necessary to control the flammable liquid fire risks, the Perimeter Solutions Variable Range Proportioner is the perfect solution for low system flow proportioning.

The primary applications for the Perimeter Solutions Variable Range Proportioner include closed-head foam/water sprinkler systems, protecting risks such as flammable and combustible liquid storage rooms, chemical processing, loading racks, aircraft hangars, and tank farm protection systems using foam chambers.

SPECIFICATIONS

The Perimeter Solutions Variable Range Proportioner is certified for use with SOLBERG RE-HEALING RF3, 3%, ARCTIC 3% AFFF and ARCTIC 3x3 ATC* foam concentrates, when used as an integral component of a SOLBERG bladder tank proportioning system. The Perimeter Solutions Variable Range Proportioner is designed to be installed as a between-the-flange proportioner, in standard 6.0" (152 mm) system piping. The foam concentrate inlet is 2.0" (50 mm) NPT female pipe size.

VARIABLE RANGE PROPORTIONER

The proportioner will accurately proportion foam concentrate at flow rates between 80 to 2,100 gpm (302 to 7949 lpm) for 3% AFFF concentrate, between 80 to 1,698 gpm (302 to 6428 lpm) for 3x3 ATC concentrate and between 108-1700 gpm (405-6435 lpm) for RE-HEALING RF3, 3% foam concentrate.

The Perimeter Solutions Variable Range Proportioner is manufactured using a bronze body and cone shaped piston, stainless steel spring, and stainless steel foam metering orifice. The Perimeter Solutions Variable Range Proportioner is to be installed with a minimum of 5 pipe diameters (30.0" (762 mm)) of straight pipe both upstream and downstream of the proportioner. The proportioner body is cast with a directional flow arrow on the proportioner body indicating the proper orientation of installation.

The Perimeter Solutions Variable Range Proportioner operation in closed-head sprinkler systems is as follows:

Under static, no flow conditions in the water supply piping, the water and foam concentrate pressures are equal. During a fire situation as sprinklers begin to open, the foam concentrate is injected into the water supply through the foam concentrate metering orifice at the proper listed solution rate.

As more sprinklers begin to operate, the change in foam-water solution demand is automatically adjusted for by the Perimeter Solutions Variable Range Proportioner, by injecting a carefully calibrated increased quantity of foam concentrate into the piping.

CERTIFICATIONS

Underwriters Laboratories, Inc. (UL) Listed - Standard 162, FM Approved per Approval Standard 5130 with RE-HEALING RF3, 3% and ARCTIC 3x3 ATC Foam Concentrates.

*See FM Approval Guide for Details

DIMENSIONAL INFORMATION

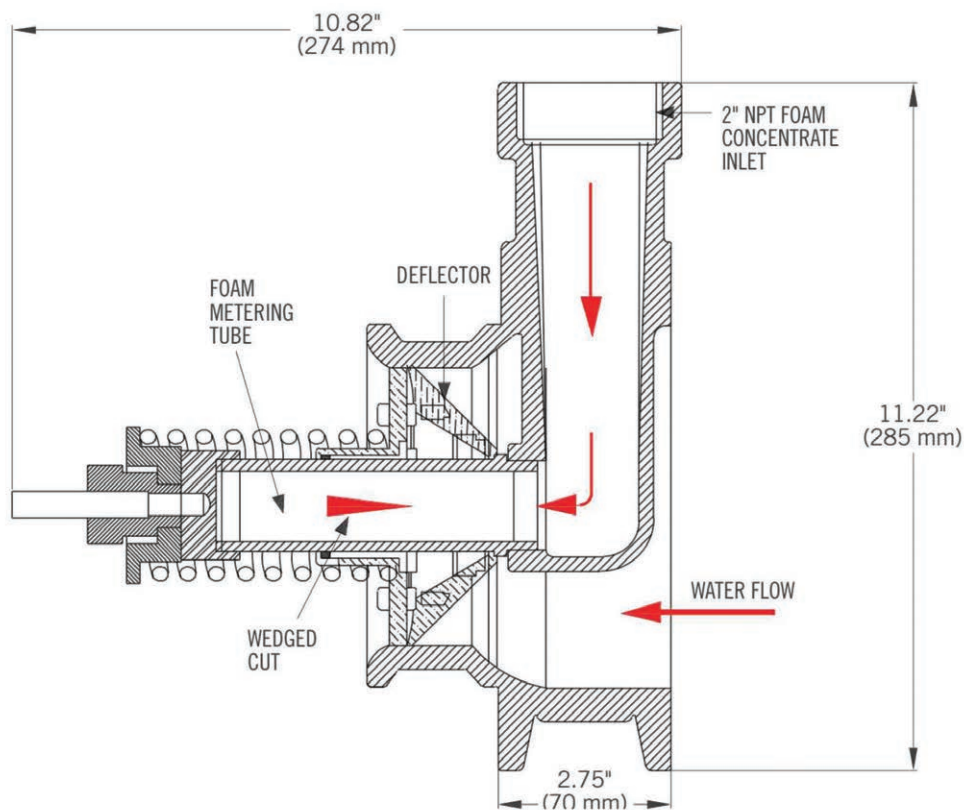

VARIABLE RANGE PROPORTIONER

PRESSURE LOSS CURVES

NOMINAL FLOW RATES

UL LISTED
RE-HEALING RF3, 3% FOAM CONCENTRATE

6 Inch Ratio Controller

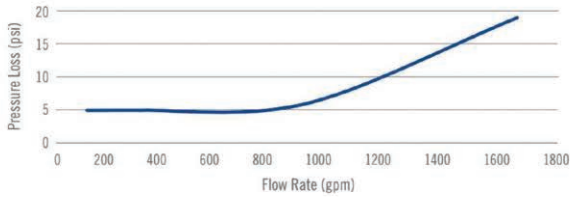

UL LISTED
ARCTIC™ 3% AFFF FOAM CONCENTRATE

6 Inch Ratio Controller

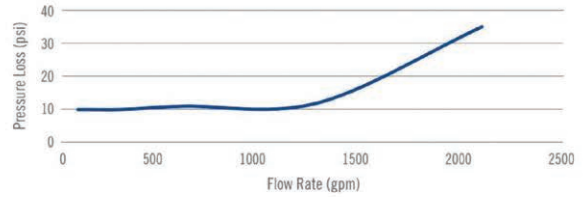

UL LISTED
ARCTIC™ 3X3% ATC™ FOAM CONCENTRATE

6 Inch Ratio Controller

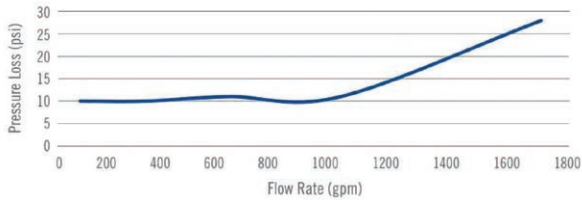

FM APPROVED
RE-HEALING RF3, 3% FOAM CONCENTRATE

6 Inch Ratio Controller

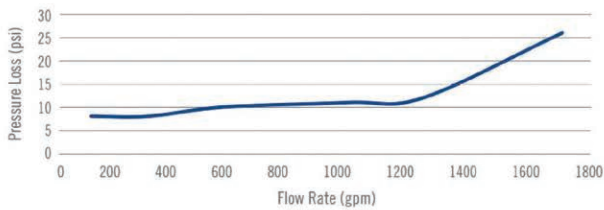

FM APPROVED
ARCTIC™ 3X3% ATC™ FOAM CONCENTRATE

6 Inch Ratio Controller

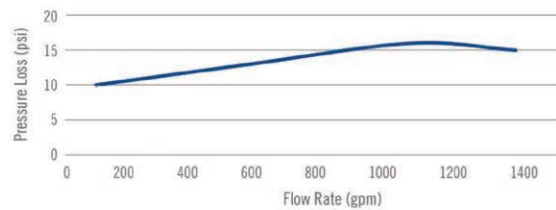

INLET PRESSURE VS. FOAM SOLUTION FLOW

FM APPROVED

RE-HEALING RF3, 3% FOAM CONCENTRATE

6 Inch Ratio Controller

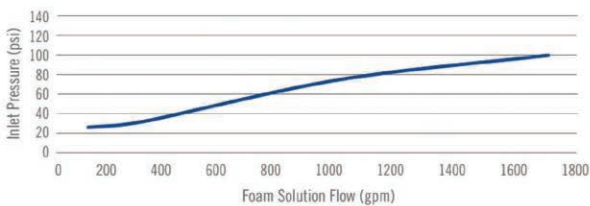

ARCTIC™ 3X3% ATC™ FOAM CONCENTRATE

6 Inch Ratio Controller

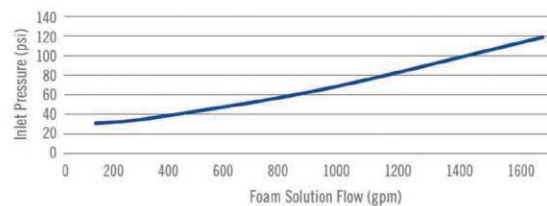

VARIABLE RANGE PROPORTIONER

PERFORMANCE INFORMATION

MODEL SRVP		UL LISTED NOMINAL FLOW			FM APPROVED NOMINAL FLOW	
		RE-HEALING RF3, 3% gpm (lpm)	ARCTIC 3% AFFF gpm (lpm)	ARCTIC 3x3% ATC gpm (lpm)	RE-HEALING RF3, 3% gpm (lpm)	ARCTIC 3x3% ATC gpm (lpm)
Proportioning Rate (pre-calibrated)	-	115-1700 (435-6435)	87-2171 (329-8218)	84-1761 (318-6666)	108-1700 (405-6435)	94-1355 (356-5129)
Size	6.0" (150 mm)	-	-	-	-	-
Foam Inlet Female	Threaded	-	-	-	-	-
Inlet Working Pressure (max.)	-	175 psi (12 bar)	175 psi (12 bar)	175 psi (12 bar)	175 psi (12 bar)	175 psi (12 bar)
Inlet Working Pressure (min.)	-	30 psi (2 bar)	30 psi (2 bar)	30 psi (2 bar)	30 psi (2 bar)	30 psi (2 bar)
Pipe Length Upstream	30.0" (762 mm)	-	-	-	-	-
Pipe Length Downstream	30.0" (762 mm)	-	-	-	-	-
Flange Size	6.0" (150 mm)	-	-	-	-	-
Between Flange Dimensions	2.75" (69 mm)	-	-	-	-	-
Height	11.0" (280 mm)	-	-	-	-	-
Weight	29 lb (13 kg)	-	-	-	-	-
Material	Bronze	-	-	-	-	-

Note: DO NOT Exceed 35.0' (11 m) of equivalent length of pipe and fittings

ORDERING INFORMATION

VARIABLE RANGE PROPORTIONER		APPROXIMATE SHIPPING WEIGHT		
PART NO.	DESCRIPTION		lb	kg
30200	Ratio Controller - Variable Range, Model SVRP 6.0" (150 mm), ARCTIC 3% AFFF	UL	28.6	13
30201	Ratio Controller - Variable Range, Model SVRP 6.0" (150 mm), ARCTIC 3x3 ATC	UL, FM	28.6	13
30210	Ratio Controller - Variable Range, Model SVRP 6.0" (150 mm), RE-HEALING RF3, 3%	FM	28.6	13
30211	Ratio Controller - Variable Range, Model SVRP 6.0" (150 mm), RE-HEALING RF3, 3%	FM	28.6	13

† Not an FM Approved Component



Solutions That Save.

FOR MORE INFORMATION

Contact any of our worldwide Perimeter Solutions Fire Safety offices or visit:

www.Perimeter-Solutions.com

UNITED STATES

10667 Jersey Blvd.
Rancho Cucamonga, CA 91730
Tel: +1 800 682 3626
Tel: +1 909 983 0772
salesfoamusa@perimeter-solutions.com

EMEA

Polígono de Baiña, Parcela 23
33682 Mieres (Asturias)
Spain
Tel: +34 985 24 29 45
salesfoamemea@perimeter-solutions.com

ASIA PACIFIC

3 Charles Street
St Marys NSW 2760 – Australia
Tel: +61 2 9673 5300
salesfoamapac@perimeter-solutions.com

perimeter-solutions.com

NOTICE PERIMETER SOLUTIONS MAKES NO REPRESENTATIONS OR WARRANTIES AS TO THE COMPLETENESS OR ACCURACY OF THE INFORMATION INCLUDED HEREIN. THE INFORMATION CONTAINED HEREIN IS NOT INTENDED TO PROVIDE REGULATORY, LEGAL OR EXPERT ADVICE RELATING TO THE PRODUCTS, ITS APPLICATION OR USES. NOTHING CONTAINED HEREIN IS TO BE CONSTRUED AS A RECOMMENDATION TO USE ANY PRODUCT, PROCESS, EQUIPMENT OR FORMULATION IN CONFLICT WITH ANY INDUSTRIAL PROPERTY OR INTELLECTUAL PROPERTY RIGHTS, AND PERIMETER SOLUTIONS MAKES NO REPRESENTATION OR WARRANTY, EXPRESS OR IMPLIED, THAT THE USE THEREOF WILL NOT INFRINGE ON ANY INDUSTRIAL PROPERTY OR INTELLECTUAL PROPERTY RIGHTS. NO REPRESENTATIONS OR WARRANTIES, EITHER EXPRESSED OR IMPLIED, OF MERCHANTABILITY, FITNESS FOR A PARTICULAR PURPOSE OR OF ANY OTHER NATURE ARE MADE HEREUNDER WITH RESPECT TO THE INFORMATION CONTAINED HEREIN.

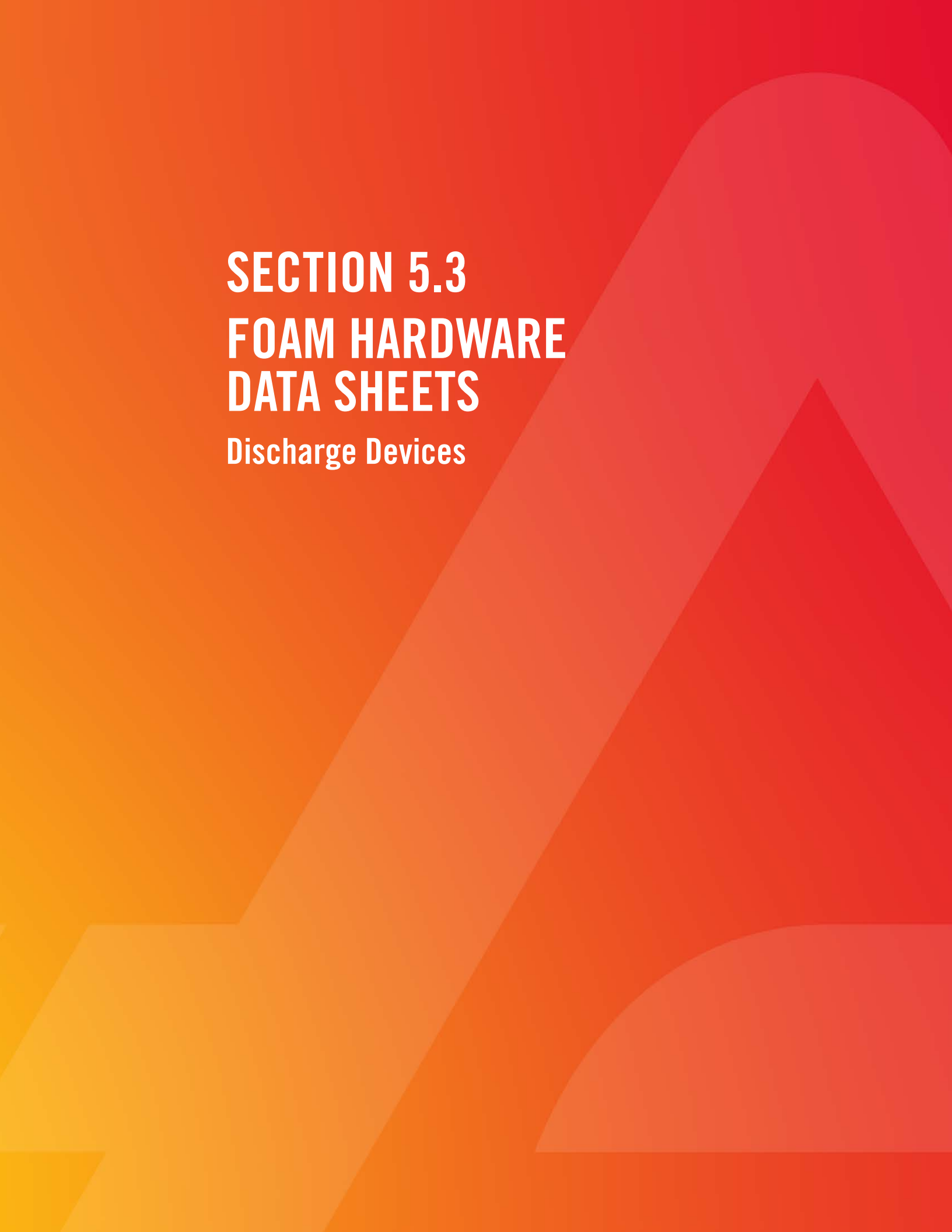
The background features a gradient from yellow-orange on the left to red on the right. Large, semi-transparent geometric shapes, including a large triangle and a rounded rectangle, are layered over the gradient.

SECTION 5.3
FOAM HARDWARE
DATA SHEETS
Discharge Devices

CONTINUOUS FLOW HOSE REEL

FEATURES

- Grease zert fittings in both supports
- Magna-cast aluminum support
- Manual rewind
- Multiple hose capabilities
- Open side design allows faster hose drying
- Single person operation
- Tension knob

DESCRIPTION

Perimeter Solutions Continuous Flow Hose Reel assemblies are manufactured with magna-cast aluminum supports and brass waterway. It also features a 1.5" (38mm) non-collapsible booster hose and brass 90-degree elbow inlet swivel with male 1.5" (38mm) NST outlet. The carbon steel reel was designed to store and deploy continuous flow hose, which allows liquid to flow while the hose is still on the reel.

APPLICATION

The hose reel assembly may be used for firefighting and/or wash down. Hose reels may also be installed in areas that require supplemental fire protection.

SPECIFICATIONS

Capacity: 1.5" X 100' hose
(38 mm X30 m)
Pressure Rating: 200 psi (14 bar)
Reel Weight: 90 lb (41 kg)



OPTIONS

- Available in stainless steel, galvanized or marine grade aluminum
- Hand crank
- Hand line nozzle with multiple flows
- Vinyl cover
- High mounting stand

CONTINUOUS FLOW HOSE REEL

DIMENSIONAL INFORMATION

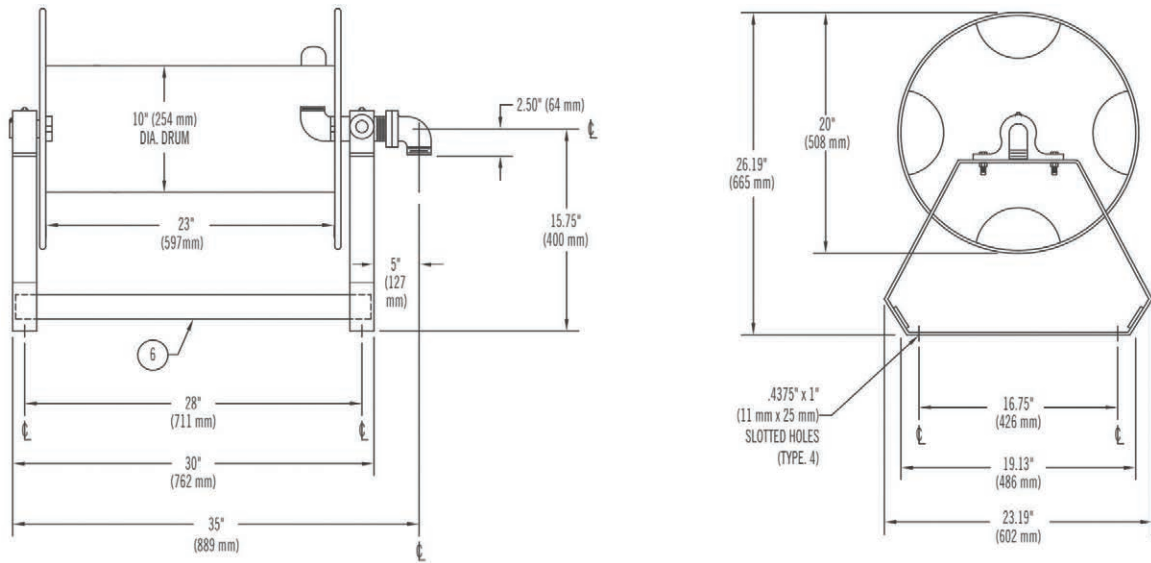

ORDERING INFORMATION

PART NO.	DESCRIPTION	APPROXIMATE SHIPPING WEIGHT	
		lb	kg
35310	Continuous Flow Hose Reel, Model SCHR-50, 50' (15 meter) Hose	142	64
35311	Continuous Flow Hose Reel, Model SCHR-75, 75' (23 meter) Hose	165	75
35312	Continuous Flow Hose Reel, Model SCHR-100, 100' (30 meter) Hose	194	88
35313	Continuous Flow Hose Reel, Model SCHR-150, 150' (46 meter) Hose	246	111



Solutions That Save.

FOR MORE INFORMATION

Contact any of our worldwide Perimeter Solutions Fire Safety offices or visit:

www.Perimeter-Solutions.com

UNITED STATES

10667 Jersey Blvd.
Rancho Cucamonga, CA 91730
Tel: +1 800 682 3626
Tel: +1 909 983 0772
salesfoamusa@perimeter-solutions.com

EMEA

Polígono de Baiña, Parcela 23
33682 Mieres (Asturias)
Spain
Tel: +34 985 24 29 45
salesfoamea@perimeter-solutions.com

ASIA PACIFIC

3 Charles Street
St Marys NSW 2760 – Australia
Tel: +61 2 9673 5300
salesfoamapac@perimeter-solutions.com

perimeter-solutions.com

NOTICE PERIMETER SOLUTIONS MAKES NO REPRESENTATIONS OR WARRANTIES AS TO THE COMPLETENESS OR ACCURACY OF THE INFORMATION INCLUDED HEREIN. THE INFORMATION CONTAINED HEREIN IS NOT INTENDED TO PROVIDE REGULATORY, LEGAL OR EXPERT ADVICE RELATING TO THE PRODUCTS, ITS APPLICATION OR USES. NOTHING CONTAINED HEREIN IS TO BE CONSTRUED AS A RECOMMENDATION TO USE ANY PRODUCT, PROCESS, EQUIPMENT OR FORMULATION IN CONFLICT WITH ANY INDUSTRIAL PROPERTY OR INTELLECTUAL PROPERTY RIGHTS, AND PERIMETER SOLUTIONS MAKES NO REPRESENTATION OR WARRANTY, EXPRESS OR IMPLIED, THAT THE USE THEREOF WILL NOT INFRINGE ON ANY INDUSTRIAL PROPERTY OR INTELLECTUAL PROPERTY RIGHTS. NO REPRESENTATIONS OR WARRANTIES, EITHER EXPRESSED OR IMPLIED, OF MERCHANTABILITY, FITNESS FOR A PARTICULAR PURPOSE OR OF ANY OTHER NATURE ARE MADE HEREUNDER WITH RESPECT TO THE INFORMATION CONTAINED HEREIN.

SOLBERG® FIRE SPRINKLERS

FEATURES

- **UL Listed and FM Approved with SOLBERG foam concentrates**
- **Upright or pendent mounted position**

DESCRIPTION

SOLBERG® foam concentrates are certified with variety of fire sprinklers for use in foam-water sprinkler systems, these included closed, open or deluge head types. Consult appropriate certification equipment directory for additional details. The simple flow geometry (patent pending) can educt foam concentrate at .5%, 1%, 3%, or 6% with no small passages to clog. Percentage is easily set with an interchangeable orifice plate. A set of calibrated foam orifice plates is included. Nozzle comes with an industrial grade UV resistant, 8 feet long, 1.5" diameter (2.4 m x 38 mm) concentrate hose with a cam lock fitting for quick and secure

attachment to the nozzle. The simple and basic design requires no grease or other maintenance. The halo ring/stream shaper is made from non-corrosive high temperature polymer. The rubber bumper is UV resistant. The MASTER FOAM self-educting nozzle is available in hardcoat anodized ANSI A356.0.T6 aluminum. All MASTER FOAM nozzles accept the FJ-LX-M FOAMJET low expansion air-aspirating attachment.

Note: Converted metric values provided are for dimensional reference only and may not reflect actual measurements.

UL LISTED

SPRINKLER MODEL	FOAM CONCENTRATE	FUEL TYPE	MINIMUM APPLICATION RATE		MINIMUM INLET PRESSURE		CERTIFICATION BODY
			gpm/ft2	(lpm/m2)	psi	(bar)	
K-FACTOR 5.6							
Reliable Automatic Sprinkler Co., ModelG SIN (I025), 1/2" (1.27 cm), K-Factor 5.6, Upright	SOLBERG RE-HEALING RF3, 3%	Hydrocarbons	0.16	(6.52)	7.0	(0.5)	UL
	SOLBERG ARCTIC 1% SP AFFF	Hydrocarbons	0.16	(6.52)	7.0	(0.5)	UL
	SOLBERG ARCTIC 3% MIL-SPEC AFFF	Hydrocarbons	0.16	(6.52)	7.0	(0.5)	UL
	SOLBERG ARCTIC 3x3% ATC	Hydrocarbons	0.16	(6.52)	7.0	(0.5)	UL
	SOLBERG ARCTIC 3x3% ATC	Alcohols	0.26	(10.59)	19.0	(1.31)	UL
Reliable Automatic Sprinkler Co., ModelG SIN (I015), 1/2" (1.27 cm), K-Factor 5.6, Pendent	SOLBERG RE-HEALING RF3, 3%	Hydrocarbons	0.16	(6.52)	7.0	(0.5)	UL
	SOLBERG ARCTIC 1% SP AFFF	Hydrocarbons	0.16	(6.52)	7.0	(0.5)	UL
	SOLBERG ARCTIC 3% MIL-SPEC AFFF	Hydrocarbons	0.16	(6.52)	7.0	(0.5)	UL
	SOLBERG ARCTIC 3x3% ATC	Hydrocarbons	0.16	(6.52)	7.0	(0.5)	UL
	SOLBERG ARCTIC 3x3% ATC	Alcohols	0.26	(10.59)	19.0	(1.31)	UL
Reliable Automatic Sprinkler Co., Model F156 SIN (RA1325), 1/2" (1.27 cm), K-Factor 5.6, Upright	SOLBERG RE-HEALING RF3, 3%	Hydrocarbons	0.16	(6.52)	7.0	(0.5)	UL
	SOLBERG ARCTIC 1% SP AFFF	Hydrocarbons	0.16	(6.52)	7.0	(0.5)	UL
	SOLBERG ARCTIC 3% MIL-SPEC AFFF	Hydrocarbons	0.16	(6.52)	7.0	(0.5)	UL
	SOLBERG ARCTIC 3x3% ATC	Hydrocarbons	0.16	(6.52)	7.0	(0.5)	UL
	SOLBERG ARCTIC 3x3% ATC	Alcohols	0.26	(10.59)	19.0	(1.31)	UL

SOLBERG® FIRE SPRINKLERS

UL LISTED CONTINUED

SPRINKLER MODEL	FOAM CONCENTRATE	FUEL TYPE	MINIMUM APPLICATION RATE		MINIMUM INLET PRESSURE		CERTIFICATION BODY
			gpm/ft2	(lpm/m2)	psi	(bar)	
K-FACTOR 5.6 CONTINUED							
Reliable Automatic Sprinkler Co., Model F156 SIN (RA1314), 1/2" (1.27 cm), K-factor 5.6, Pendent	SOLBERG RE-HEALING RF3, 3%	Hydrocarbons	0.16	(6.52)	7.0	(0.5)	UL
	SOLBERG ARCTIC 3% MIL-SPEC AFFF	Hydrocarbons	0.16	(6.52)	7.0	(0.5)	UL
	SOLBERG ARCTIC 3x3% ATC	Hydrocarbons	0.16	(6.52)	7.0	(0.5)	UL
	SOLBERG ARCTIC 3% AFFF	Hydrocarbons	0.16	(6.52)	7.0	(0.5)	UL
Reliable Automatic Sprinkler Co., Model F156 SIN (RA1425), 1/2" (1.27 cm), K-factor 5.6, Upright	SOLBERG ARCTIC 3x3% ATC	Alcohols	0.26	(10.59)	19.0	(1.31)	UL
	SOLBERG RE-HEALING RF3, 3%	Hydrocarbons	0.16	(6.52)	7.0	(0.5)	UL
	SOLBERG ARCTIC 3x3% ATC	Hydrocarbons	0.16	(6.52)	7.0	(0.5)	UL
	SOLBERG ARCTIC 3% AFFF	Hydrocarbons	0.16	(6.52)	7.0	(0.5)	UL
Reliable Automatic Sprinkler Co., Model F156 SIN (RA1425), 1/2" (1.27 cm), K-factor 5.6, Upright	SOLBERG ARCTIC 3x3% ATC	Alcohols	0.26	(10.59)	19.0	(1.31)	UL
	SOLBERG RE-HEALING RF3, 3%	Hydrocarbons	0.16	(6.52)	7.0	(0.5)	UL
	SOLBERG ARCTIC 3x3% ATC	Hydrocarbons	0.16	(6.52)	7.0	(0.5)	UL
	SOLBERG ARCTIC 3% AFFF	Hydrocarbons	0.16	(6.52)	7.0	(0.5)	UL
Reliable Automatic Sprinkler Co., Model F156 SIN (RA1414), 1/2" (1.27cm), K-factor 5.6, Pendent	SOLBERG ARCTIC 3% MIL-SPEC AFFF	Hydrocarbons	0.16	(6.52)	7.0	(0.5)	UL
	SOLBERG ARCTIC 3x3% ATC	Alcohols	0.26	(10.59)	19.0	(1.31)	UL
	SOLBERG RE-HEALING RF3, 3%	Hydrocarbons	0.16	(6.52)	7.0	(0.5)	UL
	SOLBERG ARCTIC 3x3% ATC	Hydrocarbons	0.16	(6.52)	7.0	(0.5)	UL
Reliable Automatic Sprinkler Co., Model F156 SIN (RA1425), 1/2" (1.27 cm), K-factor 5.6, Upright	SOLBERG ARCTIC 3% AFFF	Hydrocarbons	0.16	(6.52)	7.0	(0.5)	UL
Reliable Automatic Sprinkler Co., Model F156 SIN (RA1425), 1/2" (1.27 cm), K-factor 5.6, Upright	SOLBERG ARCTIC 3% AFFF	Hydrocarbons	0.16	(6.52)	7.0	(0.5)	UL
K-FACTOR 8.0							
Reliable Automatic Sprinkler Co., Model G SIN (1027), 17/32" (1.35 cm), K-factor 8.0, Upright	SOLBERG RE-HEALING RF3, 3%	Hydrocarbons	0.22	(8.96)	7.0	(0.5)	UL
	SOLBERG ARCTIC 3% MIL-SPEC AFFF	Hydrocarbons	0.22	(8.96)	7.0	(0.5)	UL
	SOLBERG ARCTIC 3x3% ATC	Hydrocarbons	0.22	(8.96)	7.0	(0.5)	UL
	SOLBERG ARCTIC 3x3% ATC	Alcohols	0.22	(8.96)	7.0	(0.5)	UL
Reliable Automatic Sprinkler Co., Model G SIN (1017), 17/32" (1.35 cm), K-factor 8.0, Pendent	SOLBERG RE-HEALING RF3, 3%	Hydrocarbons	0.22	(8.96)	7.0	(0.5)	UL
	SOLBERG ARCTIC 3% MIL-SPEC AFFF	Hydrocarbons	0.22	(8.96)	7.0	(0.5)	UL
	SOLBERG ARCTIC 3x3% ATC	Hydrocarbons	0.22	(8.96)	7.0	(0.5)	UL
	SOLBERG ARCTIC 3x3% ATC	Alcohols	0.26	(10.59)	9.5	(1.31)	UL
Reliable Automatic Sprinkler Co., Model F-1 SIN (R1 722), 17/32" (1.35 cm), K-factor 8.0, Upright	SOLBERG RE-HEALING RF3, 3%	Hydrocarbons	0.22	(8.96)	7.0	(0.5)	UL
	SOLBERG ARCTIC 3% MIL-SPEC AFFF	Hydrocarbons	0.22	(8.96)	7.0	(0.5)	UL
	SOLBERG ARCTIC 3x3% ATC	Hydrocarbons	0.22	(8.96)	7.0	(0.6)	UL
	SOLBERG ARCTIC 3x3% ATC	Alcohols	0.26	(10.59)	9.5	(1.31)	UL
Reliable Automatic Sprinkler Co., Model F-1 SIN (R1712), 17/32" (1.35 cm), K-factor 8.0, Pendent	SOLBERG RE-HEALING RF3, 3%	Hydrocarbons	0.22	(8.96)	7.0	(0.5)	UL
	SOLBERG ARCTIC 3% MIL-SPEC AFFF	Hydrocarbons	0.22	(8.96)	7.0	(0.5)	UL
	SOLBERG ARCTIC 3x3% ATC	Hydrocarbons	0.22	(8.96)	7.0	(0.5)	UL
	SOLBERG ARCTIC 3x3% ATC	Alcohols	0.26	(10.59)	9.5	(0.6)	UL
Reliable Automatic Sprinkler Co., Model F156 SIN (R3622), 17/32" (1.35cm), K-factor 8.0, Upright	SOLBERG RE-HEALING RF3, 3%	Hydrocarbons	0.16	(8.96)	7.0	(0.5)	UL
	SOLBERG ARCTIC 3x3% ATC	Hydrocarbons	0.16	(8.96)	7.0	(0.5)	UL
	SOLBERG ARCTIC 3% MIL-SPEC AFFF	Hydrocarbons	0.16	(8.96)	7.0	(0.5)	UL
	SOLBERG ARCTIC 3x3% ATC	Alcohols	0.26	(10.59)	9.5	(0.6)	UL

FIRE SPRINKLERS

UL LISTED CONTINUED

SPRINKLER MODEL	FOAM CONCENTRATE	FUEL TYPE	MINIMUM APPLICATION RATE		MINIMUM INLET PRESSURE		CERTIFICATION BODY
			gpm/ft ²	(lpm/m ²)	psi	(bar)	
K-FACTOR 8.0 CONTINUED							
Reliable Automatic Sprinkler Co., Model FIFR LO SIN (R3612), 17/32" (1.35cm), K-factor 8.0, Pendent	SOLBERG RE-HEALING RF3, 3%	Hydrocarbons	0.22	(8.96)	7.0	(0.5)	UL
	SOLBERG ARCTIC 3x3% ATC	Hydrocarbons	0.22	(8.96)	7.0	(0.5)	UL
	SOLBERG ARCTIC 3% MIL-SPEC AFFF	Hydrocarbons	0.22	(8.96)	7.0	(0.5)	UL
	SOLBERG ARCTIC 3x3% ATC	Alcohols	0.26	(10.59)	9.5	(0.6)	UL
Globe Fire Sprinkler Corp, Model GL8118 SIN (GL8164), 17/32" (1.35cm), K-factor 8.0, Upright	SOLBERG ARCTIC 3% AFFF	Hydrocarbons	0.22	(8.96)	7.0	(0.5)	UL
Globe Fire Sprinkler Corp, Model GL8106 SIN (GL8156), 17/32" (1.35cm), K-factor 8.0, Pendent	SOLBERG ARCTIC 3% AFFF	Hydrocarbons	0.22	(8.96)	7.0	(0.5)	UL

K-FACTOR 11.2							
Reliable Automatic Sprinkler Co., Model G XLO SIN (R2921), 0.64" (1.35 cm), K-factor 11.2, Upright	SOLBERG RE-HEALING RF3, 3%	Hydrocarbons	0.32	(13.02)	7.0	(0.5)	UL
	SOLBERG ARCTIC 3x3% ATC	Hydrocarbons	0.32	(13.02)	7.0	(0.5)	UL
	SOLBERG ARCTIC 3x3% ATC	Alcohols	0.37	(15.06)	9.5	(0.6)	UL

K-FACTOR 3.0							
Tyco Fire Products, Model B-1 Foam Water Sprinkler, K-factor 3.0, Upright	SOLBERG RE-HEALING RF3, 3%	Hydrocarbons	0.16	(6.52)	30.0	(2.1)	UL
	SOLBERG ARCTIC 3x3% ATC	Hydrocarbons	0.16	(6.52)	30.0	(2.1)	UL
	SOLBERG ARCTIC 3x3% ATC	Alcohols	0.16	(6.52)	30.0	(2.1)	UL
Tyco Fire Products, Model B-1 Foam Water Sprinkler, K-factor 3.0, Pendent	SOLBERG RE-HEALING RF3, 3%	Hydrocarbons	0.16	(6.52)	30.0	(2.1)	UL
	SOLBERG ARCTIC 3x3% ATC	Hydrocarbons	0.16	(6.52)	30.0	(2.1)	UL
	SOLBERG ARCTIC 3x3% ATC	Alcohols	0.16	(6.52)	30.0	(2.1)	UL

FM APPROVED

SPRINKLER MODEL	FOAM CONCENTRATE	FUEL TYPE	MINIMUM APPLICATION RATE		MINIMUM INLET PRESSURE		CERTIFICATION BODY
			gpm/ft ²	(lpm/m ²)	psi	(bar)	
K-FACTOR 5.6							
Reliable Automatic Sprinkler Co., Model F156 SIN (RA1325), 1/2" (1.27 cm), K-factor 5.6, Upright	SOLBERG RE-HEALING RF3, 3%	Hydrocarbons	0.20	(8.14)	12.7	(0.88)	FM
	SOLBERG ARCTIC 3x3% ATC	Hydrocarbons	0.20	(8.14)	12.7	(0.88)	FM
	SOLBERG ARCTIC 3x3% ATC	Alcohols	0.30	(12.21)	14.0	(0.95)	FM
Reliable Automatic Sprinkler Co., Model F156 SIN (RA1314), 1/2" (1.27 cm), K-factor 5.6, Pendent	SOLBERG RE-HEALING RF3, 3%	Hydrocarbons	0.20	(8.14)	12.7	(0.88)	FM
	SOLBERG ARCTIC 3x3% ATC	Hydrocarbons	0.20	(8.14)	12.7	(0.88)	FM
	SOLBERG ARCTIC 3x3% ATC	Alcohols	0.30	(12.21)	14.0	(0.95)	FM
K-FACTOR 8.0							
Reliable Automatic Sprinkler Co., Model G SIN (1027), 17/32" (1.35 cm), K-factor 8.0, Upright	SOLBERG RE-HEALING RF3, 3%	Hydrocarbons	0.30	(12.21)	14.0	(0.95)	FM
	SOLBERG ARCTIC 3x3% ATC	Hydrocarbons	0.30	(12.21)	14.0	(0.95)	FM
	SOLBERG ARCTIC 3x3% ATC	Alcohols	0.30	(12.21)	14.0	(0.95)	FM
Reliable Automatic Sprinkler Co., Model G SIN (1017), 17/32" (1.35 cm), K-factor 8.0, Pendent	SOLBERG RE-HEALING RF3, 3%	Hydrocarbons	0.30	(12.21)	14.0	(0.95)	FM
	SOLBERG ARCTIC 3x3% ATC	Hydrocarbons	0.30	(12.21)	14.0	(0.95)	FM
	SOLBERG ARCTIC 3x3% ATC	Alcohols	0.30	(12.21)	14.0	(0.95)	FM
Reliable Automatic Sprinkler Co., Model F-1 SIN (RI722), 17/32" (1.35 cm), K-factor 8.0, Upright	SOLBERG RE-HEALING RF3, 3%	Hydrocarbons	0.30	(12.21)	14.0	(0.95)	FM
	SOLBERG ARCTIC 3x3% ATC	Hydrocarbons	0.30	(12.21)	14.0	(0.95)	FM
	SOLBERG ARCTIC 3x3% ATC	Alcohols	0.30	(12.21)	14.0	(0.95)	FM
Reliable Automatic Sprinkler Co., Model F-1 SIN (RI712), 17/32" (1.35 cm), K-factor 8.0, Pendent	SOLBERG RE-HEALING RF3, 3%	Hydrocarbons	0.30	(12.21)	14.0	(0.95)	FM
	SOLBERG ARCTIC 3x3% ATC	Hydrocarbons	0.30	(12.21)	14.0	(0.95)	FM
	SOLBERG ARCTIC 3x3% ATC	Alcohols	0.30	(12.21)	14.0	(0.95)	FM

FIRE SPRINKLERS

FM APPROVED CONTINUED

SPRINKLER MODEL	FOAM CONCENTRATE	FUEL TYPE	MINIMUM APPLICATION RATE		MINIMUM INLET PRESSURE		CERTIFICATION BODY
			gpm/ft2	(lpm/m2)	psi	(bar)	
K-FACTOR 11.2							
Reliable Automatic Sprinkler Co., Model G XLO SIN (R2921), 0.64" (1.35 cm), K-factor 11.2, Uprigh	SOLBERG RE-HEALING RF3, 3%	Hydrocarbons	0.30	(12 21)	14.0	(0.95)	FM
	SOLBERG ARCTIC 3x3% ATC	Hydrocarbons	0.30	(12 21)	14.0	(0.95)	FM
	SOLBERG ARCTIC 3x3% ATC	Alcohols	0.30	(12 21)	14.0	(0.95)	FM



Solutions That Save.

FOR MORE INFORMATION

Contact any of our worldwide Perimeter Solutions Fire Safety offices or visit:

www.Perimeter-Solutions.com

UNITED STATES

10667 Jersey Blvd.
Rancho Cucamonga, CA 91730
Tel: +1 800 682 3626
Tel: +1 909 983 0772
salesfoamusa@perimeter-solutions.com

EMEA

Polígono de Baiña, Parcela 23
33682 Mieres (Asturias)
Spain
Tel: +34 985 24 29 45
salesfoamea@perimeter-solutions.com

ASIA PACIFIC

3 Charles Street
St Marys NSW 2760 – Australia
Tel: +61 2 9673 5300
salesfoamapac@perimeter-solutions.com

perimeter-solutions.com

NOTICE PERIMETER SOLUTIONS MAKES NO REPRESENTATIONS OR WARRANTIES AS TO THE COMPLETENESS OR ACCURACY OF THE INFORMATION INCLUDED HEREIN. THE INFORMATION CONTAINED HEREIN IS NOT INTENDED TO PROVIDE REGULATORY, LEGAL OR EXPERT ADVICE RELATING TO THE PRODUCTS, ITS APPLICATION OR USES. NOTHING CONTAINED HEREIN IS TO BE CONSTRUED AS A RECOMMENDATION TO USE ANY PRODUCT, PROCESS, EQUIPMENT OR FORMULATION IN CONFLICT WITH ANY INDUSTRIAL PROPERTY OR INTELLECTUAL PROPERTY RIGHTS, AND PERIMETER SOLUTIONS MAKES NO REPRESENTATION OR WARRANTY, EXPRESS OR IMPLIED, THAT THE USE THEREOF WILL NOT INFRINGE ON ANY INDUSTRIAL PROPERTY OR INTELLECTUAL PROPERTY RIGHTS. NO REPRESENTATIONS OR WARRANTIES, EITHER EXPRESSED OR IMPLIED, OF MERCHANTABILITY, FITNESS FOR A PARTICULAR PURPOSE OR OF ANY OTHER NATURE ARE MADE HEREUNDER WITH RESPECT TO THE INFORMATION CONTAINED HEREIN.

FOAM CHAMBERS

FEATURES

- Available in four size ranges
- Equipped with an inspection opening on the cover plate
- Minimum operating pressure 40 psi (3 bar), maximum operating pressure 100 psi (7 bar)
- One-piece welded chambers are available for installations not requiring vapor seal

DESCRIPTION

Perimeter Solutions Foam Chambers are N FPA-11 Type 11 air aspirating foam discharge devices that provide protection for open top floating and cone roof flammable liquid storage tanks. Foam chambers are a combination of a foam mixing chamber and a foam maker with an air inlet. A removable orifice plate is located between the flange inlet and solution pipe flange, and is sized to deliver the required foam solution at a specified pressure. A frangible glass vapor seal located in the foam chamber body prevents product vapors from entering the foam chamber body. The vapor seal will break once the foam solution enters, filling the foam chamber body with expanded foam. The foam flows to a deflector plate, which directs the foam to the inside of the storage tank wall and fuel surface, only allowing minimum foam submergence and fuel agitation.

APPLICATION

Perimeter Solutions Foam Chambers are airaspirating Type II discharge devices that protect various types of flammable liquid storage tanks including cone roof tanks (with or without internal floaters) and open top floating roof tanks. The foam chambers are typically used with bladder tank systems or balanced pressure pump systems.



SPECIFICATIONS

The foam chamber assembly consists of the body, integral foam maker, orifice, deflector, vapor seal, gaskets and mounting hardware. The foam chamber body is constructed of steel. The inlet fitting is a raised face 150 lb flange, and the outlet fitting is a flat faced 150 lb flange that can be bolted or welded to the storage tank. Foam chamber body has a cover plate with inspection opening for ease of inspection or access to the vapor seal. Vapor seal is constructed from glass and designed to meet the UL required burst pressure range of 10 - 25 psi (1 - 2 bar). The deflector face can be either solid or split-type and constructed from steel that can be bolted or welded to side of storage tank.

Foam Chambers are prepared and finished with Perimeter Solutions red or blue enamel finish.

CERTIFICATIONS

Underwriters Laboratories, Inc. (UL) Listed - Standard 162, FM Approved per Approval Standard 5130.

FOAM CHAMBERS

FLOW RATES

FM APPROVED

SFS 825 (C = .615)	RE-HEALING RF3, 3% gpm (lpm)	psi (bar)
MAX ORIFICE 0.938	181 (685)	100 (7)
	162 (613)	80 (6)
	143 (541)	60 (4)

SFS 1240 (C = .635)	RE-HEALING RF3, 3% gpm (lpm)	psi (bar)
MAX ORIFICE 1.875	680 (2574)	100 (7)
	621 (2351)	80 (6)
	525 (1987)	60 (4)

MIN ORIFICE 0.625	84 (318)	100 (7)
	75 (284)	80 (6)
	64 (242)	60 (4)
	60 (227)	50 (3)

MIN ORIFICE 1.125	251 (950)	100 (7)
	222 (840)	80 (6)
	194 (734)	60 (4)
	164 (621)	40 (3)

SFS 1030 (C = .625)	RE-HEALING RF3, 3% gpm (lpm)	psi (bar)
MAX ORIFICE 1.25	315 (1192)	100 (7)
	285 (1079)	80 (6)
	245 (927)	60 (4)
	220 (833)	50 (3)

SFS 1660* (C = .650)	gpm (lpm)	psi (bar)
MAX ORIFICE 1.875	680 (2574)	100 (7)
	621 (2351)	80 (6)
	525 (1987)	60 (4)

MIN ORIFICE 0.875	156 (590)	100 (7)
	137 (519)	80 (6)
	120 (454)	60 (4)
	95 (360)	40 (3)

MIN ORIFICE 1.125	251 (950)	100 (7)
	222 (840)	80 (6)
	194 (734)	60 (4)
	164 (621)	40 (3)

*non-UL Listed, non-FM Approved

FLOW RATES

UL LISTED

SFS 825 (C = .615)	FLOW RANGE	
	CONCENTRATE	MIN. ORIFICE 0.625 - MAX. ORIFICE 0.938
	RE-HEALING RF3, 3%	60 -181 pgm (227 -685 lpm)
	ARCTIC 1 % AFFF	48 - 179 gpm (182 -678 lpm)
	ARCTIC 3% AFFF	49 -180 gpm (185 -681 lpm)
	ARCTIC 1x3% ATC	51 -84 gpm (193 -318 lpm)
	ARCTIC 3x3% ATC	46-180 gpm (174-681 lpm)

SFS 1030 (C = .625)	FLOW RANGE	
	CONCENTRATE	MIN. ORIFICE 0.875 - MAX. ORIFICE 1.25
	RE-HEALING RF3, 3%	95 -315 gpm (360 -1192 lpm)
	ARCTIC 1 % AFFF	94 - 312 gpm (356 - 1181 lpm)
	ARCTIC 3% AFFF	96 -316 gpm (363 - 1196 lpm)
	ARCTIC 1x3% ATC	N/A
	ARCTIC 3x3% ATC	94 - 312 gpm (356 -1181 lpm)

SFS 1240 (C = .635)	FLOW RANGE	
	CONCENTRATE	MIN. ORIFICE 1.125 - MAX. ORIFICE 1.875
	RE-HEALING RF3, 3%	164 -680 pgm (621-2575 lpm)
	ARCTIC 1 % AFFF	149 - 695 gpm (564-2631 lpm)
	ARCTIC 3% AFFF	147 -720 gpm (556 -2725 lpm)
	ARCTIC 1x3% ATC	N/A
	ARCTIC 3x3% ATC	150 -695 gpm (568-2631 lpm)

FOAM CHAMBERS

ORIFICE PLATE SIZING

English

$$D = \sqrt{\frac{Q}{29.8 \times C \times \sqrt{P}}}$$

Metric

$$D = \sqrt{\frac{Q}{0.6659 \times C \times \sqrt{P}}}$$

Key

Q = Flow in GPM

D = Diameter of Orifice in Inches

C = Coefficient of Discharge for the Orifice (See C factor above)

P = Pressure in psi

DIMENSIONAL INFORMATION

APPROXIMATE DIMENSIONS Inches (Millimeters)

MODEL	A	B	C	D	E	F	G	H	J	K
SFS 825	26.25 (667)	17.00 (432)	5.75 (146)	11.50 (292)	4.50 (114)	7.00 (178)	2.50 (64)	7.50 (191)	.63 (16)	8.00 (203)
SFS 1030	32.13 (816)	19.00 (483)	6.50 (165)	13.00 (330)	6.63 (168)	9.00 (229)	3.00 (76)	9.50 (241)	.75 (19)	9.50 (241)
SFS 1240	35.75 (908)	22.00 (559)	7.75 (197)	15.50 (394)	8.75 (222)	10.00 (254)	4.00 (102)	11.75 (298)	.88 (22)	11.00 (279)
SFS 1660	41.38 (1051)	23.63 (600)	9.50 (241)	19.00 (483)	10.81 (275)	12.00 (305)	6.00 (152)	14.25 (362)	1.00 (25)	12.00 (305)

FOAM CHAMBER

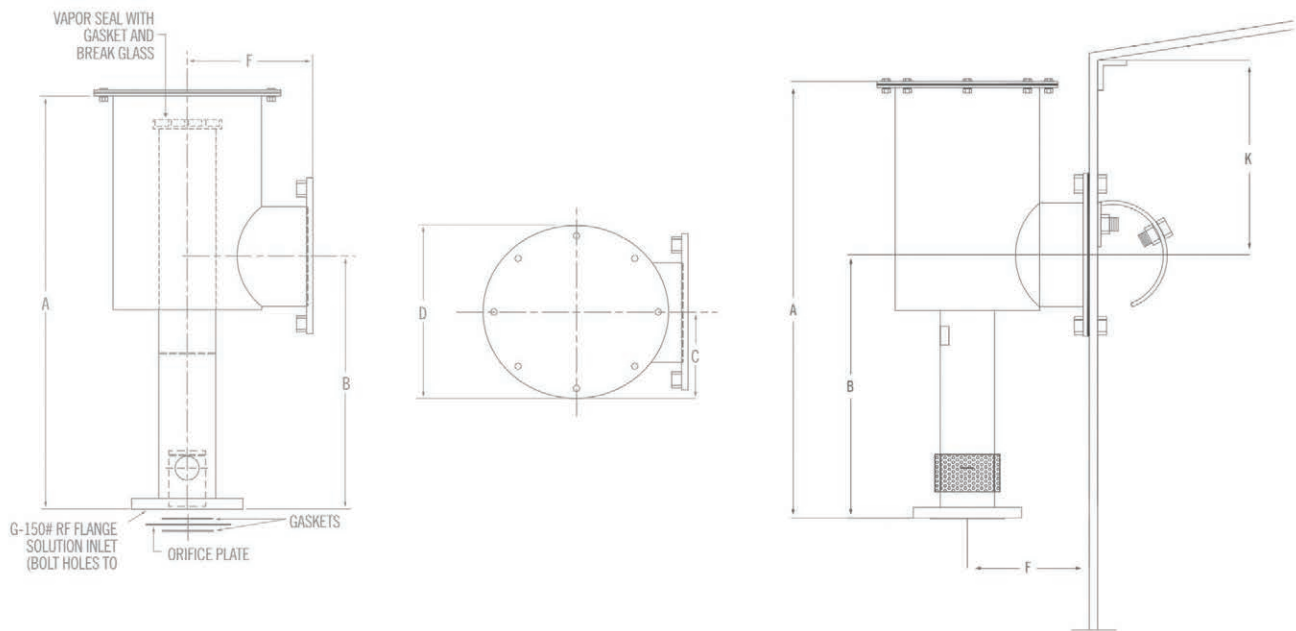

FOAM CHAMBERS

INSTALLATION INFORMATION

FOAM CHAMBER MOUNTING

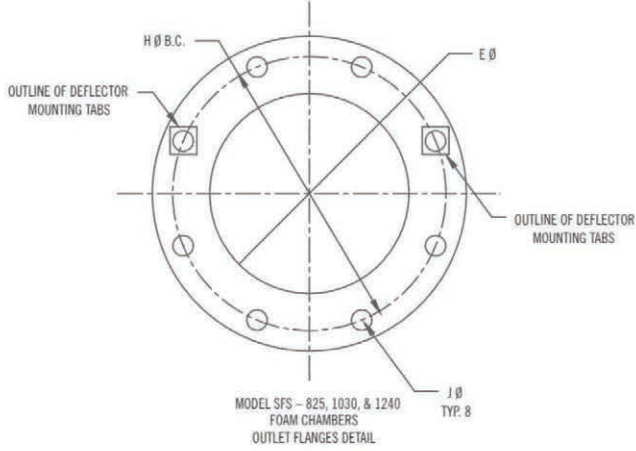

BOLTED WITH PAD, SPLIT DEFLECTOR

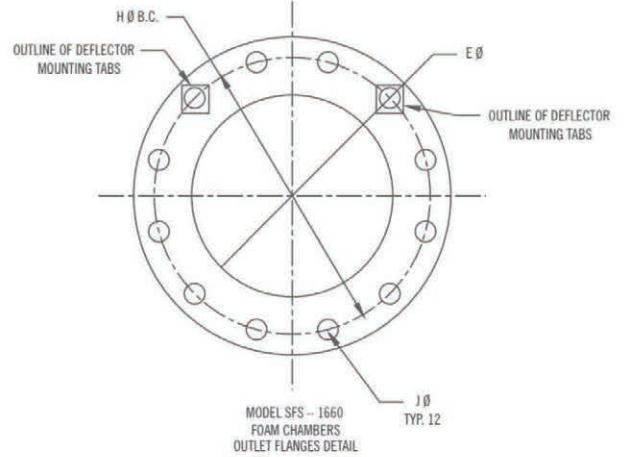

BOLTED WITH PAD, SPLIT DEFLECTOR

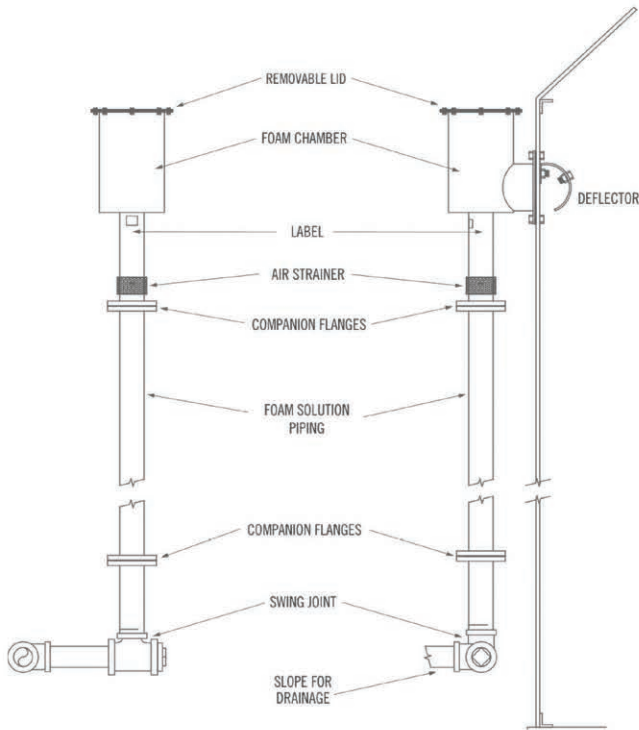

BOLTED WITH PAD, SPLIT DEFLECTOR

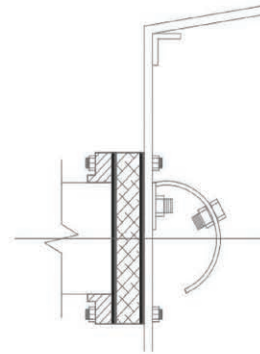

BOLTED WITH PAD, SHALLOW DEFLECTOR

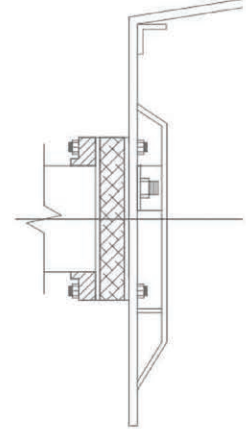

WELDED WITH SPLIT DEFLECTOR

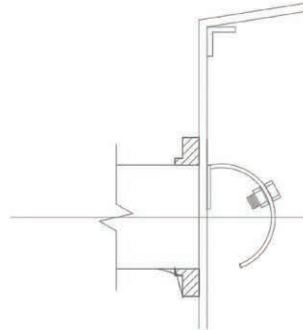

WELDED WITH SHALLOW DEFLECTOR

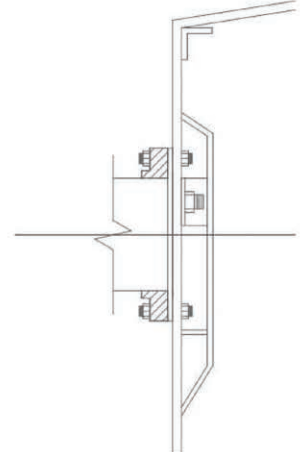

Note: This installation information provides only general guidelines. Each installation may require modifications to meet specific requirements or application(s). Perimeter Solutions reserves the right to change any portion of this information without notice.

FOAM CHAMBERS

ORDERING INFORMATION

FOAM CHAMBERS		APPROXIMATE SHIPPING WEIGHT	
PART NO.	DESCRIPTION	lb	kg
32100	Foam Chamber, Model SFS-825, Red Enamel Finish	46	21
32101	Split Deflector Plate, Model SFS-825, Red Enamel Finish	5	2
32102	Solid Deflector Plate, Model SFS-825, Red Enamel Finish	5	2
32103	Foam Chamber, Model SFS-1030, Red Enamel Finish	84	38
32104	Split Deflector Plate, Model SFS-1030, Red Enamel Finish	6	3
32105	Solid Deflector Plate, Model SFS-1030, Red Enamel Finish	6	3
32106	Foam Chamber, Model SFS-1240, Red Enamel Finish	92	42
32107	Split Deflector Plate, Model SFS-1240, Red Enamel Finish	9	5
32108	Solid Deflector Plate, Model SFS-1240, Red Enamel Finish	9	5
32109	Foam Chamber, Model SFS-1660, Red Enamel Finish	163	74
32110	Split Deflector Plate, Model SFS-1660, Red Enamel Finish	12	5
32111	Solid Deflector Plate, Model SFS-1660, Red Enamel Finish	12	5

FOAM CHAMBER - REPLACEMENT PARTS		APPROXIMATE SHIPPING WEIGHT	
PART NO.	DESCRIPTION	lb	kg
32120	Vapor Seal Assembly, Model SFS-825	0.50	0.2
32121	Vapor Seal Assembly, Model SFS-1030	0.50	0.2
32122	Vapor Seal Assembly, Model SFS-1240	0.50	0.2
32123	Vapor Seal Assembly, Model SFS-1660	0.50	0.2
32124	Cover Gasket, Model SFS-825	0.25	0.1
32125	Cover Gasket, Model SFS-1030	0.25	0.1
32126	Cover Gasket, Model SFS-1240	0.25	0.1
32127	Cover Gasket, Model SFS-1660	0.25	0.1
32128	Orifice Plate, Model SFS-825	1.00	0.4
32129	Orifice Plate, Model SFS-1030	1.00	0.4
32130	Orifice Plate, Model SFS-1240	1.00	0.4
32131	Orifice Plate, Model SFS-1660	1.00	0.4



Solutions That Save.

FOR MORE INFORMATION

Contact any of our worldwide Perimeter Solutions Fire Safety offices or visit:

www.Perimeter-Solutions.com

UNITED STATES

10667 Jersey Blvd.
Rancho Cucamonga, CA 91730
Tel: +1 800 682 3626
Tel: +1 909 983 0772
salesfoamusa@perimeter-solutions.com

EMEA

Polígono de Baiña, Parcela 23
33682 Mieres (Asturias)
Spain
Tel: +34 985 24 29 45
salesfoamemea@perimeter-solutions.com

ASIA PACIFIC

3 Charles Street
St Marys NSW 2760 – Australia
Tel: +61 2 9673 5300
salesfoamapac@perimeter-solutions.com

perimeter-solutions.com

NOTICE PERIMETER SOLUTIONS MAKES NO REPRESENTATIONS OR WARRANTIES AS TO THE COMPLETENESS OR ACCURACY OF THE INFORMATION INCLUDED HEREIN. THE INFORMATION CONTAINED HEREIN IS NOT INTENDED TO PROVIDE REGULATORY, LEGAL OR EXPERT ADVICE RELATING TO THE PRODUCTS, ITS APPLICATION OR USES. NOTHING CONTAINED HEREIN IS TO BE CONSTRUED AS A RECOMMENDATION TO USE ANY PRODUCT, PROCESS, EQUIPMENT OR FORMULATION IN CONFLICT WITH ANY INDUSTRIAL PROPERTY OR INTELLECTUAL PROPERTY RIGHTS, AND PERIMETER SOLUTIONS MAKES NO REPRESENTATION OR WARRANTY, EXPRESS OR IMPLIED, THAT THE USE THEREOF WILL NOT INFRINGE ON ANY INDUSTRIAL PROPERTY OR INTELLECTUAL PROPERTY RIGHTS. NO REPRESENTATIONS OR WARRANTIES, EITHER EXPRESSED OR IMPLIED, OF MERCHANTABILITY, FITNESS FOR A PARTICULAR PURPOSE OR OF ANY OTHER NATURE ARE MADE HEREUNDER WITH RESPECT TO THE INFORMATION CONTAINED HEREIN.

FOAM MAKERS

FEATURES

- **Stainless steel construction for corrosive environments**
- **Air inlets covered with stainless steel mesh to protect against blockage and damage**
- **Inlet orifice machined and sized to match specific flow and pressure rates**
- **Multiple sizes available**
- **Supplied with Standard NPT threaded female inlet and male outlet**

DESCRIPTION

Perimeter Solutions Foam Makers (SFM) are available in various models with nominal flow rates ranging from 6 - 300 gpm (25 - 1136 lpm) at 30 - 150 psi (2 - 10 bar) with threaded inlets and outlets. The stainless steel discharge tube incorporates a mixing barrel, an orifice plate (sized for the required flow at a given pressure) and an air inlet to allow air into the foam solution stream to generate expanded foam. The foam maker is normally installed in the line of a semi-fixed or fixed foam fire protection system.

APPLICATION

Perimeter Solutions Foam Makers are airaspirating foam discharge devices used primarily for the protection of the seal area of open top floating roof storage tanks and dike areas around storage tanks. Additional applications include protection of spill hazards and diked flammable liquid storage areas.

Foam Makers are used with numerous types of proportioning systems including atmospheric tanks, bladder tanks, balanced pressure pump proportioning systems or line proportioners.



Perimeter Solutions Foam Makers can be used with RE-HEALING and ARCTIC foam concentrates for the suppression of Class B flammable liquids.

FLOW RANGE

The flow rate of a Perimeter Solutions Foam Maker is determined by the orifice size and inlet pressure. The flow rates listed in the following table are based on the minimum operating pressure of 30 psi (2 bar) and the maximum operating pressure of 150 psi (10 bar) required for satisfactory operation*

CERTIFICATIONS

FM Approved per Approval Standard 5130
(*see FM Approval Guide).

FOAM MAKERS

DIMENSIONAL INFORMATION

MODEL	CONCENTRATE	FLOW RATE (MIN - MAX)	PRESSURE (MIN - MAX)	APPROXIMATE DIMENSIONS Inches (Millimeters)		
				INLET	OUTLET	LENGTH
SFM-1.5	RE-HEALING RF3, 3%	34 - 68 gpm (129 - 257 lpm)	40 - 150 psi (3 - 10 bar)	1.5 (38)	1.5 (38)	17.0 (432)
SFM - 2.5*		102 - 197 gpm (386 - 746 lpm)	40 - 150 psi (3 - 10 bar)	2.5 (64)	2.5 (64)	28.0 (711)
SFM-1.5*	ARCTIC 3x3% ATC	35 gpm (132 lpm)	42 psi (3 bar)	1.5 (38)	1.5 (38)	17.0 (432)
SFM - 1.5*		60 - 75 gpm (227 - 284 lpm)	100 - 150 psi (7 - 10 bar)	1.5 (38)	1.5 (38)	17.0 (432)
SFM-DT30, 1.5		25 - 56 gpm (95 - 212 lpm)	98 - 150 psi (7 - 10 bar)	1.5 (38)	1.5 (38)	17.0 (432)
SFM - 2.5		20 gpm (76 lpm)	N/A	2.5 (64)	2.5 (64)	28.0 (711)
SFM-DT30, 1.5	ARCTIC 3x3% CG ATC	20 gpm (76 lpm)	150 psi (10 bar)	1.5 (38)	1.5 (38)	17.0 (432)

Note: † non-UL Listed, non-FM Approved. * FM Approval Guide hydrocarbon fuels only.

MODEL SFM-1.5

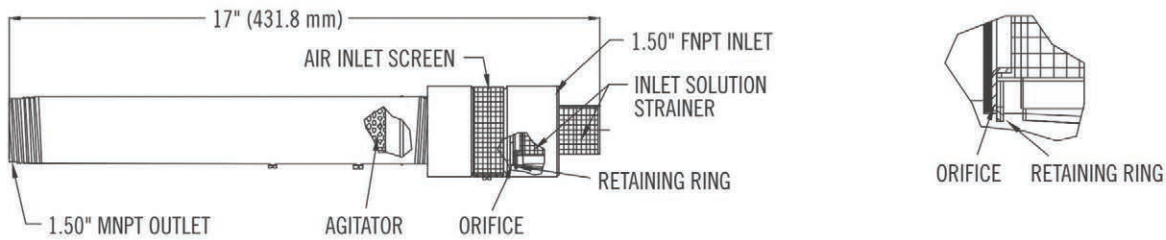

MODEL SFM-2.5

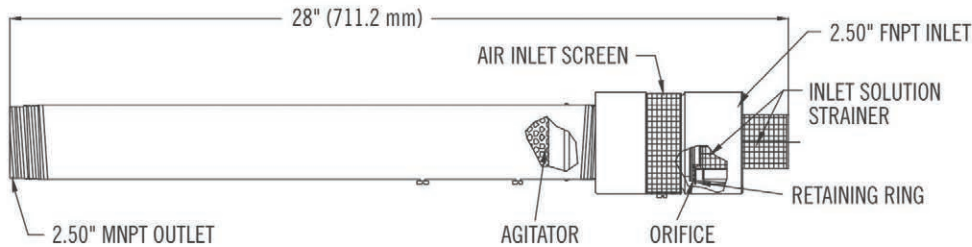

MODEL	"K" FACTOR RANGE
SFM-1.5	1.8 - 12.2
SFM-2.5	18.2 - 24.49
SFM-DT30, 1.5	2.5 - 4.6

FOAM MAKERS

TYPICAL DIKED PROTECTION INSTALLATION

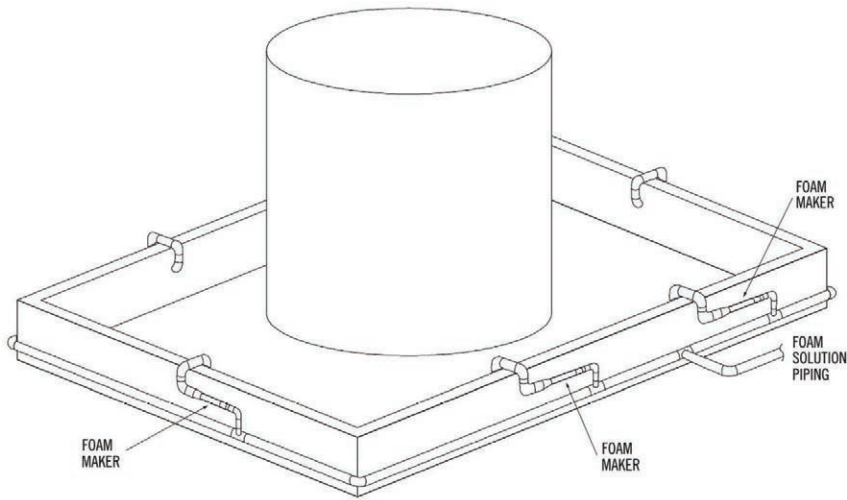

FLOATING ROOF TANK INSTALLATION

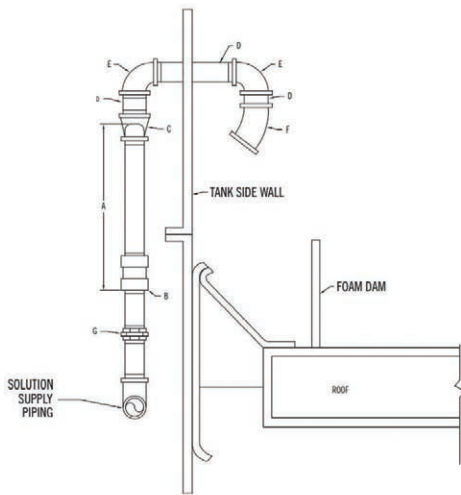

DIKED AREA INSTALLATION

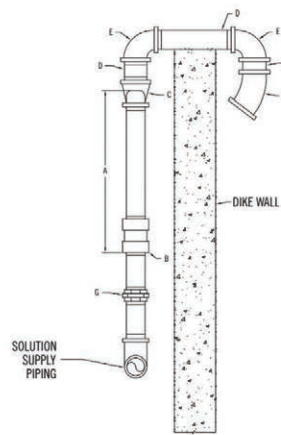

APPROXIMATE DIMENSIONS Inches (Millimeters)

A	B	C	D	E	F	G
SFM - 1.5 (38)	1.5 - 11.5 (38-292) NPT	1.5 x 2.5 (38 x 64) Red. Coup.	2.5 (64) Nipple	2.5 (64) 90° Elbow	2.5 (64) 45° Elbow	1.5 (38) Union
SFM - 2.5 (64)	2.5 - 8 (64-203) NPT	2.5 x 4 (64 x 102) Red. Coup.	4 (102) Nipple	4 (102) 90° Elbow	4 (102) 45° Elbow	2.5 (64) Union
SFM-D130, 1.5 (38)	1.5 - 11.5 (38 - 292) NPT	1.5 x 2.5 (38 x 64) Red. Coup.	2.5 (64) Nipple	2.5 (64) 90° Elbow	2.5 (64) 45° Elbow	1.5 (38) Union

FOAM MAKERS

ORDERING INFORMATION

FOAM MAKERS		APPROXIMATE SHIPPING WEIGHT	
PART NO.	DESCRIPTION	lb	kg
32154	Foam Maker, Model SFM-1.5	7	3
32155	Foam Maker, Model SFM-2.5	8	4
32156	Foam Maker, Model SFM-D13 0, 1.5	7	3



Solutions That Save.

FOR MORE INFORMATION

Contact any of our worldwide Perimeter Solutions Fire Safety offices or visit:

www.Perimeter-Solutions.com

UNITED STATES

10667 Jersey Blvd.
Rancho Cucamonga, CA 91730
Tel: +1 800 682 3626
Tel: +1 909 983 0772
salesfoamusa@perimeter-solutions.com

EMEA

Polígono de Baiña, Parcela 23
33682 Mieres (Asturias)
Spain
Tel: +34 985 24 29 45
salesfoamea@perimeter-solutions.com

ASIA PACIFIC

3 Charles Street
St Marys NSW 2760 – Australia
Tel: +61 2 9673 5300
salesfoamapac@perimeter-solutions.com

perimeter-solutions.com

NOTICE PERIMETER SOLUTIONS MAKES NO REPRESENTATIONS OR WARRANTIES AS TO THE COMPLETENESS OR ACCURACY OF THE INFORMATION INCLUDED HEREIN. THE INFORMATION CONTAINED HEREIN IS NOT INTENDED TO PROVIDE REGULATORY, LEGAL OR EXPERT ADVICE RELATING TO THE PRODUCTS, ITS APPLICATION OR USES. NOTHING CONTAINED HEREIN IS TO BE CONSTRUED AS A RECOMMENDATION TO USE ANY PRODUCT, PROCESS, EQUIPMENT OR FORMULATION IN CONFLICT WITH ANY INDUSTRIAL PROPERTY OR INTELLECTUAL PROPERTY RIGHTS, AND PERIMETER SOLUTIONS MAKES NO REPRESENTATION OR WARRANTY, EXPRESS OR IMPLIED, THAT THE USE THEREOF WILL NOT INFRINGE ON ANY INDUSTRIAL PROPERTY OR INTELLECTUAL PROPERTY RIGHTS. NO REPRESENTATIONS OR WARRANTIES, EITHER EXPRESSED OR IMPLIED, OF MERCHANTABILITY, FITNESS FOR A PARTICULAR PURPOSE OR OF ANY OTHER NATURE ARE MADE HEREUNDER WITH RESPECT TO THE INFORMATION CONTAINED HEREIN.

FOAM STATION

FEATURES

- Completely self-contained unit
- Operates with AFFF or Alcohol Type Concentrates (ATC™)
- Operates with water only
- Rechargeable while in operation
- Storage reel for 1.5" X 100' (38 mm X 30 m) (booster) non-collapsible hose

DESCRIPTION

The Perimeter Solutions Foam Station is a quick knock down, one-man operation foam station. The unit is self-contained, consisting of a 35 gallon (132 litre) stainless steel concentrate tank, eductor, hand line nozzle and non-collapsible hose. When in operation, water is introduced from a dedicated water source through the supply hose to the eductor. While water is passing through the eductor a vacuum is created, which draws foam concentrate out of the tank, up to the eductor and into the water stream, delivering the foam solution.

APPLICATION

The Perimeter Solutions Foam Station is designed to provide firefighting capabilities in various high-hazard high-risk applications such as:

- Aircraft hangars
- Off-shore platforms
- Dike areas
- Spill fires
- Tank farms



SPECIFICATIONS (STANDARD UNIT)

- 1.0" (25 mm) drain valve with plug
- 1.5" (38 mm) 100' non-collapsible hose
- 4.0" (102 mm) PVC fill port and vent
- Stainless steel handle
- 35 gallon (132 litres) stainless steel (304) concentrate tank
- Hand line 95 gpm (360 lpm) Nozzle
- Brass eductor with 95 gpm (360 lpm)
- Brass manifold
- Galvanized hose reel
- Stainless steel pick up tube

OPTIONS

- 50' (15 m), 75' (23 m), 125' (38 m) or 150' (46 m) hose lengths
- 60 gallon (227 litre) concentrate tank
- 316SS, galvanized or carbon steel manifold
- Handline Nozzle
- Stainless steel (316) tank material
- Stainless steel, aluminum or carbon steel hose reel

FOAM STATION

DIMENSIONAL INFORMATION (STANDARD UNIT)

Height:	46" (1168 mm)
Length:	50" (1270 mm)
Width:	35" (889 mm)
Weight with foam:	35 gallon station 400 lbs (181 kg) 60 gallon station 622 lbs (282 kg)

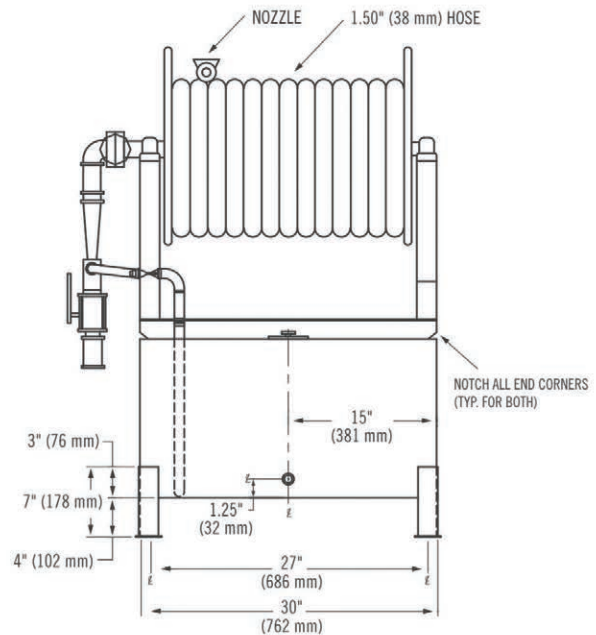
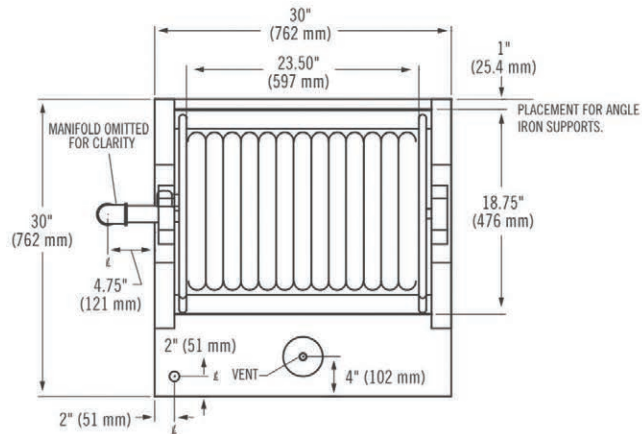

ORDERING INFORMATION

FOAM STATIONS	PART NO.	DESCRIPTION	APPROXIMATE SHIPPING WEIGHT	
			lb	kg
	35002	Foam Station - 35 gallon (133 litre), Stainless Steel, Hose Reel, Nozzle, Hose 75' (23 m), Red Enamel Finish	130	59
	35003	Foam Station - 35 gallon (133 litre), Stainless Steel, Hose Reel, Nozzle, Hose 100' (30 m), Red Enamel Finish	130	59
	35004	Foam Station - 60 gallon (227 litre), Stainless Steel, Hose Reel, Nozzle, Hose 75' (23 m), Red Enamel Finish	160	73
	35005	Foam Station - 60 gallon (227 litre), Stainless Steel, Hose Reel, Nozzle, Hose 100' (30 m), Red Enamel Finish	160	73



Solutions That Save.

FOR MORE INFORMATION

Contact any of our worldwide Perimeter Solutions Fire Safety offices or visit:

www.Perimeter-Solutions.com

UNITED STATES

10667 Jersey Blvd.
Rancho Cucamonga, CA 91730
Tel: +1 800 682 3626
Tel: +1 909 983 0772
salesfoamusa@perimeter-solutions.com

EMEA

Polígono de Baiña, Parcela 23
33682 Mieres (Asturias)
Spain
Tel: +34 985 24 29 45
salesfoamemea@perimeter-solutions.com

ASIA PACIFIC

3 Charles Street
St Marys NSW 2760 – Australia
Tel: +61 2 9673 5300
salesfoamapac@perimeter-solutions.com

perimeter-solutions.com

NOTICE PERIMETER SOLUTIONS MAKES NO REPRESENTATIONS OR WARRANTIES AS TO THE COMPLETENESS OR ACCURACY OF THE INFORMATION INCLUDED HEREIN. THE INFORMATION CONTAINED HEREIN IS NOT INTENDED TO PROVIDE REGULATORY, LEGAL OR EXPERT ADVICE RELATING TO THE PRODUCTS, ITS APPLICATION OR USES. NOTHING CONTAINED HEREIN IS TO BE CONSTRUED AS A RECOMMENDATION TO USE ANY PRODUCT, PROCESS, EQUIPMENT OR FORMULATION IN CONFLICT WITH ANY INDUSTRIAL PROPERTY OR INTELLECTUAL PROPERTY RIGHTS, AND PERIMETER SOLUTIONS MAKES NO REPRESENTATION OR WARRANTY, EXPRESS OR IMPLIED, THAT THE USE THEREOF WILL NOT INFRINGE ON ANY INDUSTRIAL PROPERTY OR INTELLECTUAL PROPERTY RIGHTS. NO REPRESENTATIONS OR WARRANTIES, EITHER EXPRESSED OR IMPLIED, OF MERCHANTABILITY, FITNESS FOR A PARTICULAR PURPOSE OR OF ANY OTHER NATURE ARE MADE HEREUNDER WITH RESPECT TO THE INFORMATION CONTAINED HEREIN.

HIGH BACK PRESSURE FOAM MAKER

FEATURES

- 150 lb flanged inlet and outlet
- Compatible with Solberg foam concentrates for subsurface injection
- Engineered to operate with total back pressure up to 25% of inlet pressure
- Inlet orifice machined and sized to match specific flow and pressure rates
- Optional stainless steel material (upon request)



DESCRIPTION

Perimeter Solutions High Back Pressure Foam Makers (HBPfM) are available in four models with nominal flow rates ranging from 100 - 400 gpm (379 -1514 lpm) with flange inlets and outlets. The carbon steel discharge tube has four air induction holes placed 90 degrees apart to allow air into the foam solution stream to generate expanded foam.

APPLICATION

Perimeter Solutions HBPfM is a device designed to provide expanded foam to hydrocarbon cone roof storage tanks for subsurface application. The HBPfM is located outside the diked area and piped to a dedicated fire protection line or tank product line. The HBPfM is capable of producing expanded foam. HBPfMs are designed to discharge expanded foam against a back pressure up to 25% of operating inlet pressure. Perimeter Solutions HBPfM operate at pressures of 50 - 300 psi (3 - 21 bar). A 100 psi (7 bar) minimum operating pressure is typically required for satisfactory operation.

DIMENSIONAL INFORMATION

APPROXIMATE DIMENSIONS Inches (Millimeters)

MODEL	FLOW AT PRESSURE	INLET	OUTLET	LENGTH
SFS-100-20	100 gpm at 150 psig (379 lpm at 10 bar)	2.0 (51)	2.0 (51)	15.69 (399)
SFS-200-25	200 gpm at 150 psig (757 lpm at 10 bar)	2.5 (64)	2.5 (64)	20.81 (529)
SFS-300-30	300 gpm at 150 psig (1136 lpm at 10 bar)	3.0 (76)	3.0 (76)	23.02 (585)
SFS-400-40	400 gpm at 150 psig (1514 lpm at 10 bar)	4.0 (1016)	4.0 (1016)	29.02 (737)

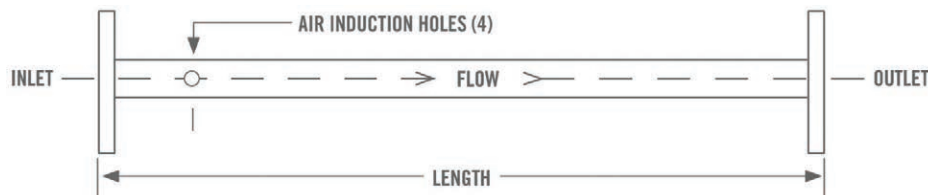

Note: Inlets and Outlets are 150# Flanges

HIGH BACK PRESSURE FOAM MAKER

For the flow rate at other pressures, use the "K" Factor listed below for each model in the formula $Q = K \sqrt{P}$ where Q is the flow in gpm (lpm), K is a constant factor and P is the inlet pressure for psig (bar).

MODEL	"K" FACTOR
SFS-100-20	8.18
SFS-200-25	16.33
SFS-300-30	24.49
SFS-400-40	46.13

The back pressure within a system is calculated by the formula:

$$\text{BACK PRESSURE (psig/bar)} = (\Delta P/FT) (X+Y) + \frac{(\text{DENSITY})(Z)}{2.3}$$

Where ΔP = pressure drop in pipe size used (psig/bar). X = the fitting (in equivalent feet (meters) of pipe), Y = pipe length in feet and Z = fuel depth. Total back pressure must be $\leq 25\%$ of inlet pressure.

SOLBERG High Back Pressure Foam Makers operate at 50 - 300 psi (3 - 21 bar) and produce foam expansion of 2.2 - 4.0:1 ratios.

All back pressure and inlet velocities are based on a normal 4:1 expansion.

ORDERING INFORMATION

HIGH BACK PRESSURE FOAM MAKER		APPROXIMATE SHIPPING WEIGHT	
PART NO.	DESCRIPTION	lb	kg
32170	HBP Foam Maker, Model SFS-100-20	32	14
32171	HBP Foam Maker, Model SFS-200-25	34	15
32172	HBP Foam Maker, Model SFS-300-30	36	16
32173	HBP Foam Maker, Model SFS-400-40	38	17



Solutions That Save.

FOR MORE INFORMATION

Contact any of our worldwide Perimeter Solutions Fire Safety offices or visit:

www.Perimeter-Solutions.com

UNITED STATES

10667 Jersey Blvd.
 Rancho Cucamonga, CA 91730
 Tel: +1 800 682 3626
 Tel: +1 909 983 0772
salesfoamusa@perimeter-solutions.com

EMEA

Polígono de Baiña, Parcela 23
 33682 Mieres (Asturias)
 Spain
 Tel: +34 985 24 29 45
salesfoamemea@perimeter-solutions.com

ASIA PACIFIC

3 Charles Street
 St Marys NSW 2760 – Australia
 Tel: +61 2 9673 5300
salesfoamapac@perimeter-solutions.com

perimeter-solutions.com

NOTICE PERIMETER SOLUTIONS MAKES NO REPRESENTATIONS OR WARRANTIES AS TO THE COMPLETENESS OR ACCURACY OF THE INFORMATION INCLUDED HEREIN. THE INFORMATION CONTAINED HEREIN IS NOT INTENDED TO PROVIDE REGULATORY, LEGAL OR EXPERT ADVICE RELATING TO THE PRODUCTS, ITS APPLICATION OR USES. NOTHING CONTAINED HEREIN IS TO BE CONSTRUED AS A RECOMMENDATION TO USE ANY PRODUCT, PROCESS, EQUIPMENT OR FORMULATION IN CONFLICT WITH ANY INDUSTRIAL PROPERTY OR INTELLECTUAL PROPERTY RIGHTS, AND PERIMETER SOLUTIONS MAKES NO REPRESENTATION OR WARRANTY, EXPRESS OR IMPLIED, THAT THE USE THEREOF WILL NOT INFRINGE ON ANY INDUSTRIAL PROPERTY OR INTELLECTUAL PROPERTY RIGHTS. NO REPRESENTATIONS OR WARRANTIES, EITHER EXPRESSED OR IMPLIED, OF MERCHANTABILITY, FITNESS FOR A PARTICULAR PURPOSE OR OF ANY OTHER NATURE ARE MADE HEREUNDER WITH RESPECT TO THE INFORMATION CONTAINED HEREIN.

The background features a gradient from yellow-orange on the left to red on the right. Large, semi-transparent geometric shapes, including a large triangle and a rounded rectangle, are layered over the gradient.

SECTION 5.4

FOAM HARDWARE

DATA SHEETS

Mobile Products

MOBILE FOAM CART

FEATURES

- 2.5" X 1.5", 95 gpm inline eductor, mounted (64 mm X 38 mm, 360 /pm)
- 35 gallon (133 litres) stainless steel tank
- Heavy duty industrial 16.0" X 4.0" (406 mm X 102 mm) wheels and tires
- One person operation
- Rugged frame
- Two hose storage racks capable of holding 50 ft (15 m) fire hose

DESCRIPTION

The Perimeter Solutions Mobile Foam Cart is designed and constructed for oneperson operation. This foam station can function at its full potential quickly in an emergency situation.

Foam concentrate is stored in a 35 gallon (133 litres) stainless steel tank equipped with a 95 gpm (360 lpm) eductor and pick-up tube. The pick-up tube is connected to the tank and utilizes a metering device to determine what percentage of foam concentrate is introduced into the water stream. On the inlet of the eductor, a supply fire hose is connected that delivers water from an independent source. A fire hose and discharge nozzle are connected to the outlet. When in operation, water flows through the eductor creating a vacuum that draws foam concentrate out of the tank to the metering valve of the eductor and into the water stream, delivering foam solution to the nozzle.

Note: gpm (lpm) of nozzle and eductor must match or unit will not operate as intended.

APPLICATION

The Perimeter Solutions Foam Cart is designed to provide firefighting capabilities to multiple hazard areas containing Class B fuels. Common high-hazard high-risk areas include:

- Flammable liquid storage
- Mining operations
- Paint storage areas
- Tank farms
- Wood manufacturing/processing areas



SPECIFICATIONS

The foam cart consists of a 35 gallon (133 litre) stainless steel foam concentrate tank with two fire hose storage compartments. The frame is constructed of stainless steel tube and angle. Eductor material is brass. The eductor is a 2.5" X 1.5" (64 mm X 38 mm) inline eductor with pick-up tube and metering valve for adjustment of 1% to 6% proportioning. Two 50 ft (15 m) hose lengths are provided. The inlet hose is 2.5" X 50' (64 mm X 15 m) coupled and the outlet hose is 1.5" X 50' (38 mm X 15 m). Handline nozzles are not included. Handline nozzle capable of use with the foam cart could be medium expansion, air-aspirated or non-air aspirated nozzles with the same gpm (lpm) as the eductor.

OPTIONS

- 1.5" (38 mm) nozzle
- 1.5" X 50' hose (38 mm X 15 m)
- 2.5" X 50' hose (64 mm X 15 m)
- 95 or 125 gpm (360 or 473 lpm) by-pass manifold - stainless steel
- Hydrant-spanner wrench set
- For use with Solberg foam concentrates (RE-HEALING™, ARCTIC™, FIRE-BRAKE™)
- Vinyl cover

MOBILE FOAM CART

DIMENSIONAL INFORMATION

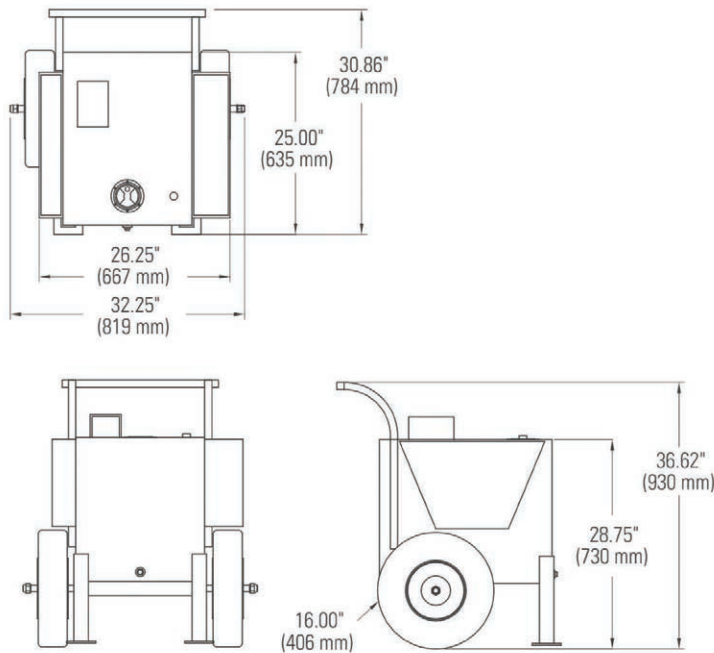

ORDERING INFORMATION

MOBILE FOAM CART		APPROXIMATE SHIPPING WEIGHT	
PART NO.	DESCRIPTION	lb	kg
33000	Mobile Foam Cart, Stainless Steel Tank, 35 gallon (133 litre), 95 gpm (360 lpm)	400	181



Solutions That Save.

FOR MORE INFORMATION

Contact any of our worldwide Perimeter Solutions Fire Safety offices or visit:

www.Perimeter-Solutions.com

UNITED STATES

10667 Jersey Blvd.
Rancho Cucamonga, CA 91730
Tel: +1 800 682 3626
Tel: +1 909 983 0772
salesfoamusa@perimeter-solutions.com

EMEA

Polígono de Baiña, Parcela 23
33682 Mieres (Asturias)
Spain
Tel: +34 985 24 29 45
salesfoamea@perimeter-solutions.com

ASIA PACIFIC

3 Charles Street
St Marys NSW 2760 – Australia
Tel: +61 2 9673 5300
salesfoamapac@perimeter-solutions.com

perimeter-solutions.com

NOTICE PERIMETER SOLUTIONS MAKES NO REPRESENTATIONS OR WARRANTIES AS TO THE COMPLETENESS OR ACCURACY OF THE INFORMATION INCLUDED HEREIN. THE INFORMATION CONTAINED HEREIN IS NOT INTENDED TO PROVIDE REGULATORY, LEGAL OR EXPERT ADVICE RELATING TO THE PRODUCTS, ITS APPLICATION OR USES. NOTHING CONTAINED HEREIN IS TO BE CONSTRUED AS A RECOMMENDATION TO USE ANY PRODUCT, PROCESS, EQUIPMENT OR FORMULATION IN CONFLICT WITH ANY INDUSTRIAL PROPERTY OR INTELLECTUAL PROPERTY RIGHTS, AND PERIMETER SOLUTIONS MAKES NO REPRESENTATION OR WARRANTY, EXPRESS OR IMPLIED, THAT THE USE THEREOF WILL NOT INFRINGE ON ANY INDUSTRIAL PROPERTY OR INTELLECTUAL PROPERTY RIGHTS. NO REPRESENTATIONS OR WARRANTIES, EITHER EXPRESSED OR IMPLIED, OF MERCHANTABILITY, FITNESS FOR A PARTICULAR PURPOSE OR OF ANY OTHER NATURE ARE MADE HEREUNDER WITH RESPECT TO THE INFORMATION CONTAINED HEREIN.

MOBILE FOAM CART (POLYETHYLENE TANK)

FEATURES

- One person operation
- Rugged frame
- 35 gallon (130 litres) polyethylene tank
- 1.5" or 2.5", inline eductor, mounted
- Hose storage rack capable of holding 50 ft (15 m) fire hose
- Heavy duty industrial 16.0" x 4.0" (406 mm x 102 mm) wheels and tires

DESCRIPTION

The Perimeter Solutions Mobile Foam Cart is designed and constructed for one-person operation. This foam station can function at its full potential quickly in an emergency situation.

Foam concentrate is stored in a 35 gallon (130 litres) polyethylene tank equipped with a 66 gpm

(250 lpm), 106 gpm (400 lpm) or 211 gpm (800 lpm) eductor and pick-up tube. The pick-up tube is connected to the tank and utilizes a metering device to determine what percentage of foam concentrate is introduced into the water stream. On the inlet of the eductor, a supply fire hose is connected that delivers water from an independent source. A fire hose and discharge nozzle are connected to the outlet. When in operation, water flows through the eductor creating a vacuum that draws foam concentrate out of the tank to the metering valve of the eductor and into the water stream, delivering foam solution to the nozzle.

Note: gpm (lpm) of nozzle and eductor must match or unit will not operate as intended.

APPLICATION

The Perimeter Solutions Foam Cart is designed to provide firefighting capabilities to multiple hazard areas containing Class B fuels. Common high-hazard high-risk areas include:

- Flammable liquid storage
- Mining operations
- Paint storage areas
- Tank farms
- Wood manufacturing/processing areas



SPECIFICATIONS

The foam cart consists of a 35 gallon (130 litre) polyethylene foam concentrate tank. The frame is constructed of carbon steel tube and angle. Eductor material is brass. The eductor is either a 1.5" (38mm) or 2.5" (63mm) inline eductor with pick-up tube and metering valve for adjustment of 3% or 6% proportioning. One 50 ft (15 m) hose length with threaded couplings is provided. The inlet hose is 1.5" x 50' (38 mm x 15 m) or 2.5" x 50' (63 mm x 15 m) coupled and the outlet hose is 1.5" x 50' (38 mm x 15 m) or 2.5" x 50' (63 mm x 15 m) depending on model type. Handline nozzle is included. Alternative (customer supplied) handline nozzles capable for use with the foam cart include medium expansion, air-aspirated or non-air aspirated nozzles with the same gpm (lpm) as the eductor.

OPTIONS

- STORZ fittings
- 1.5" x 50' hose (38 mm x 15 m)
- 2.5" x 50' hose (64 mm x 15 m)
- 66, 106 or 211 gpm (250, 400 or 800 lpm) by-pass manifold - stainless steel
- Hydrant-spanner wrench set
- For use with Solberg foam concentrates (RE-HEALING™, ARCTIC™, FIRE-BRAKE™)
- Vinyl cover

MOBILE FOAM CART

DIMENSIONAL INFORMATION

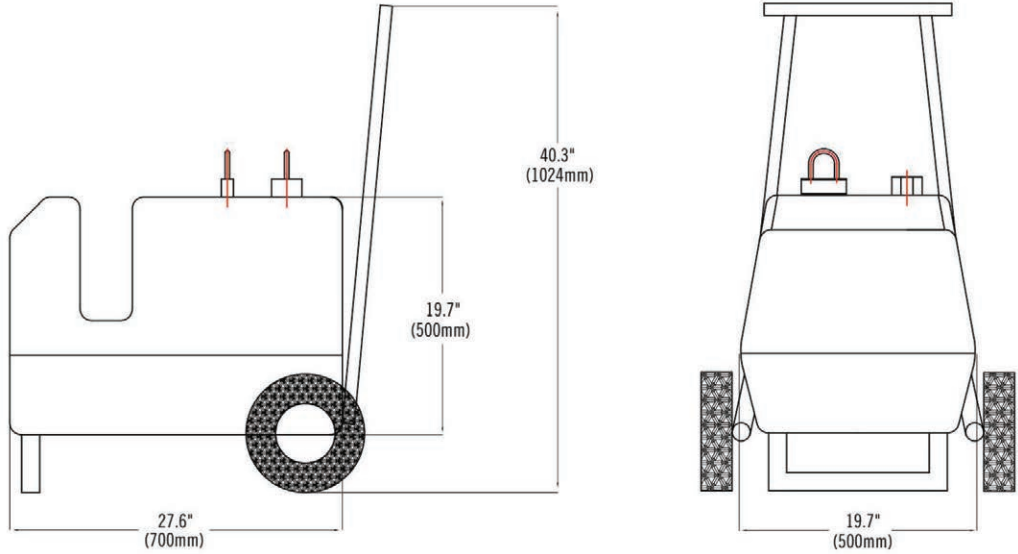

ORDERING INFORMATION

MOBILE FOAM CART PART NO.	DESCRIPTION	APPROXIMATE SHIPPING WEIGHT		APPROXIMATE CUBE
		lb	kg	L x D x H
33002	Mobile Foam Cart, Polyethylene Tank, 35 gallon (130 litre), 66 gpm (250 lpm)	154	70	25" X 30" X 55" 635mm x 762mm x 1400mm
33003	Mobile Foam Cart, Polyethylene Tank, 35 gallon (130 litre), 106 gpm (400 lpm)	154	70	
33004	Mobile Foam Cart, Polyethylene Tank, 35 gallon (130 litre), 211 gpm (800 lpm)	156	71	



Solutions That Save.

FOR MORE INFORMATION

Contact any of our worldwide Perimeter Solutions Fire Safety offices or visit:

www.Perimeter-Solutions.com

UNITED STATES

10667 Jersey Blvd.
Rancho Cucamonga, CA 91730
Tel: +1 800 682 3626
Tel: +1 909 983 0772
salesfoamusa@perimeter-solutions.com

EMEA

Polígono de Baiña, Parcela 23
33682 Mieres (Asturias)
Spain
Tel: +34 985 24 29 45
salesfoamea@perimeter-solutions.com

ASIA PACIFIC

3 Charles Street
St Marys NSW 2760 – Australia
Tel: +61 2 9673 5300
salesfoamapac@perimeter-solutions.com

perimeter-solutions.com

NOTICE PERIMETER SOLUTIONS MAKES NO REPRESENTATIONS OR WARRANTIES AS TO THE COMPLETENESS OR ACCURACY OF THE INFORMATION INCLUDED HEREIN. THE INFORMATION CONTAINED HEREIN IS NOT INTENDED TO PROVIDE REGULATORY, LEGAL OR EXPERT ADVICE RELATING TO THE PRODUCTS, ITS APPLICATION OR USES. NOTHING CONTAINED HEREIN IS TO BE CONSTRUED AS A RECOMMENDATION TO USE ANY PRODUCT, PROCESS, EQUIPMENT OR FORMULATION IN CONFLICT WITH ANY INDUSTRIAL PROPERTY OR INTELLECTUAL PROPERTY RIGHTS, AND PERIMETER SOLUTIONS MAKES NO REPRESENTATION OR WARRANTY, EXPRESS OR IMPLIED, THAT THE USE THEREOF WILL NOT INFRINGE ON ANY INDUSTRIAL PROPERTY OR INTELLECTUAL PROPERTY RIGHTS. NO REPRESENTATIONS OR WARRANTIES, EITHER EXPRESSED OR IMPLIED, OF MERCHANTABILITY, FITNESS FOR A PARTICULAR PURPOSE OR OF ANY OTHER NATURE ARE MADE HEREUNDER WITH RESPECT TO THE INFORMATION CONTAINED HEREIN.

FOAM TRAILER

FEATURES

- Trailer design offers extreme mobility
- Single, dual or multiple polypropylene tote design available
- Metal concentrate tank or custom design trailers also available
- Totes containers are manufactured of high density polyethylene and are incased in a rigid galvanized steel grid. Available in 265 gallon (1003 litre) and 320 gallon (1211 litres) capacities
- Standard size metal tanks available in sizes of 500, 750, and 1000 gallons (1893, 2839, 3785 litres). Note: Custom designed sizes available to meet customer needs
- Trailer constructed of all welded steel
- High flow capacity
- Self-educting nozzle
- Accessory options available including NFPA 1901 compliance
- Meet DOT highway requirements

DESCRIPTION

The Perimeter Solutions Foam Trailer consists of the following: A complete mobile package meeting all applicable NFPA standards consisting of a trailer constructed with frame, wheels, and axles capable of carrying the total charged weight of the trailer assembly and the foam concentrate. The trailer frame includes a tongue jack, electrical connections, NFPA 1901 lighting package (optional), reflective striping, rear mud flaps, and rear stabilizer jacks. The foam system can utilize either of two foam storage vessel designs: polyethylene tote(s), either single, dual, multiple or a rigidly constructed metal foam tank. The foam monitor is capable of delivering up to 1000 gpm (3785 lpm) of foam solution at a pressure of 100 psi (7.0 bar). The monitor connections are up to 3.0" (76 mm). The self-educting monitor nozzle is capable of delivering up to 1000 gpm (3785 lpm) at 100 psi (7.0 bar).

APPLICATION

The Perimeter Solutions Foam Trailer is designed to provide quick, mobile foam fire protection for hazards consisting of flammable liquids. These types of hazards can be defined as tank farms, loading racks (both truck and rail), chemical processing plants, and marine off loading/on loading terminals. The trailer storage vessel, either tote(s) or metal tank, provides a large capacity supply of foam concentrate. The pre-piped monitor and nozzle allow for the foam system to be put into action very rapidly. The Perimeter Solutions Foam Trailer greatly increases the firefighting ability of industrial, municipal, and military fire emergency responders.



SPECIFICATIONS

Trailer Frame

The trailer frame shall be constructed of all welded steel. No bolts, screws, or rivets shall be used in the construction of the frame. The trailer framework shall be constructed of 4.0" x 2.0" x 0.125" (102 mm x 51 mm x 3.2 mm) wall steel tubing. The cross members shall be notched at their ends to fit inside of the outer frame channels. Cross members shall be positioned to maximize support for the foam totes, monitors, and plumbing. Two lengths of 4.0" (102 mm) channel shall be welded diagonally between the coupler and the front corners of the frame. The front of the trailer (monitor operators position), shall be covered with 0.125" (3.2 mm) embossed aluminum diamond plate. Mounting provisions shall be provided for the foam tank(s). The trailer shall be equipped with 2-5/16" coupler, adjustable front jack, two rear stabilizer jacks, and full light package for highway use.

Axles

The axles shall be rated a minimum of 3500 lb (1588 kg) load rating each. The axles shall be bolted to the frame utilizing Grade 8 bolts. The axles shall consist of torsion bar suspension and independent wheel movement to provide maximum shock absorption and proper handling.

Brakes

The trailer assembly shall contain an electric brake system.

NFPA Lighting Package (optional)

The trailer shall contain a light package that meets the minimum warning light and actuation requirements of NFPA 1901 Fire Apparatus Standard (current edition).

Hose Bins

Two hose bins shall be provided. Each located above each of the trailer fenders.

FOAM TRAILER

Tote Tank

Each tote foam storage container(s) shall be sized to hold 265 gallons (1003 litres) (or optional 320 gallon (1211 litres)) of foam concentrate. The tote shall be constructed of high density polyethylene. The tote shall be enclosed by a galvanized steel base and rigid, welded galvanized tubular steel grid.

Metal Tank

The optional metal foam storage container shall be sized to hold 500, 750, or 1000 gallons (1893, 2839, 3785 litres) of foam concentrate. The metal tank shall be constructed of painted steel, or stainless steel, of sufficient gauge. Custom designed sizes shall be available to meet customer needs.

Foam Tank Connection

Foam connection hoses shall be constructed of 1.5" (38 mm) or 2.0" (50 mm) suction hose to allow foam flow. Cam and groove couplings shall be used to enable quick connection and disconnection of the foam concentrate hoses.

Foam Monitor

The 3.0" (76 mm) monitor inlet shall be provided at the front of the trailer. The inlet shall terminate with a 3.0" (76 mm) or 4.0" (102 mm) 4-bolt 150# flange. The discharge shall be gated with a 3.0" (76 mm) quarter turn ball valve. The valve controller shall be located on the valve. The monitor shall be bolted directly to the 3.0" flange. Threaded 0.25" NPT ports shall be provided for drain valve and pressure gauge. Maximum flow capacity of 1000 gpm (3785 lpm) shall be based on monitor type selected.

Self-Educting Foam Nozzle

Fixed gallonage combination, fog, straight stream, self-educing, constant gallonage foam nozzle shall be available with a flow rate up to 1000 gpm (3785 lpm) at 100 psi (7.0 bar) (specify) and user selected foam proportioning ratios of 0.5%, 1.0%, 3.0%, or 6.0%. Nozzle shall be hard coat anodized aluminum alloy or brass. Nozzle shall include an industrial hard grade UV resistant 1.5" (38 mm) concentrate pick-up hose with cam lock connection to the nozzle foam inlet and a UV resistant front rubber bumper and halo ring for pattern adjustment.

Finish

The trailer shall be prepared and finished with SOLBERG blue or red enamel finish.

Options

Contact Perimeter Solutions Technical Services for options on monitors, hoses, and other trailer equipment.

DIMENSIONAL INFORMATION

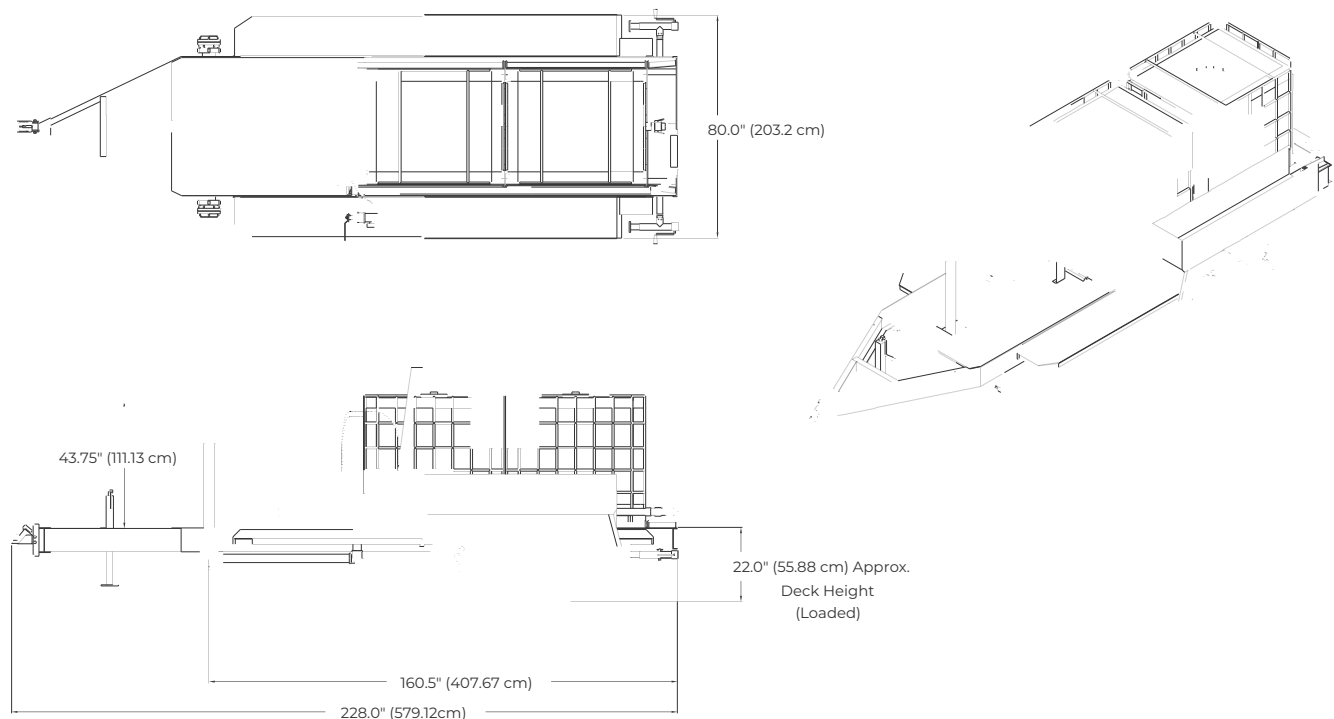

Note: Drawings are conceptual and representative in nature. Dimensions are approximates and will vary depending on model and options selected at time of purchase.

SOLBERG® FOAM TRAILER

ORDERING INFORMATION

Contact Perimeter Solutions Technical Services Department for options, pricing and delivery.



Solutions That Save.

FOR MORE INFORMATION

Contact any of our worldwide Perimeter Solutions Fire Safety offices or visit:

www.Perimeter-Solutions.com

UNITED STATES

10667 Jersey Blvd.
Rancho Cucamonga, CA 91730

Tel: +1 800 682 3626

Tel: +1 909 983 0772

salesfoamusa@perimeter-solutions.com

EMEA

Polígono de Baiña, Parcela 23
33682 Mieres (Asturias)
Spain

Tel: +34 985 24 29 45

salesfoamemea@perimeter-solutions.com

ASIA PACIFIC

3 Charles Street
St Marys NSW 2760 – Australia

Tel: +61 2 9673 5300

salesfoamapac@perimeter-solutions.com

perimeter-solutions.com

NOTICE PERIMETER SOLUTIONS MAKES NO REPRESENTATIONS OR WARRANTIES AS TO THE COMPLETENESS OR ACCURACY OF THE INFORMATION INCLUDED HEREIN. THE INFORMATION CONTAINED HEREIN IS NOT INTENDED TO PROVIDE REGULATORY, LEGAL OR EXPERT ADVICE RELATING TO THE PRODUCTS, ITS APPLICATION OR USES. NOTHING CONTAINED HEREIN IS TO BE CONSTRUED AS A RECOMMENDATION TO USE ANY PRODUCT, PROCESS, EQUIPMENT OR FORMULATION IN CONFLICT WITH ANY INDUSTRIAL PROPERTY OR INTELLECTUAL PROPERTY RIGHTS, AND PERIMETER SOLUTIONS MAKES NO REPRESENTATION OR WARRANTY, EXPRESS OR IMPLIED, THAT THE USE THEREOF WILL NOT INFRINGE ON ANY INDUSTRIAL PROPERTY OR INTELLECTUAL PROPERTY RIGHTS. NO REPRESENTATIONS OR WARRANTIES, EITHER EXPRESSED OR IMPLIED, OF MERCHANTABILITY, FITNESS FOR A PARTICULAR PURPOSE OR OF ANY OTHER NATURE ARE MADE HEREUNDER WITH RESPECT TO THE INFORMATION CONTAINED HEREIN.

FOAM PROPORTIONING TRAILER

FEATURES

- Trailer design offers extreme mobility
- Steel concentrate tanks available in sizes of 500, 750, 1000 gallons (1893, 2839, 3785 liters) Note: Custom designed sizes available.
- High flow capacity
- Wide range of proportioning
- Proportioning system meets the requirements of NFPA 11
- Multiple size tank options
- Trailer constructed of all welded steel
- Meets DOT highway requirements
- UL Listed proportioning system
- Accessory options available including NFPA 1901 compliance
- Easy refilling during operation

DESCRIPTION

The Perimeter Solutions Foam Proportioning Trailer consists of the following: A complete mobile package meeting all applicable NFPA standards consisting of a trailer constructed with frame, wheels, and axles capable of carrying the total charged weight of the trailer assembly and the foam concentrate. The trailer frame includes a tongue jack, electrical connections, NFPA 1901 lighting package, reflective striping, rear mud flaps, and rear stabilizer jacks. Concentrate tanks are available in 500, 750, 1000 gallon (1893, 2839, 3785 liters) capacities. Tanks are constructed of carbon steel in accordance with NFPA 11C "Mobile Foam Apparatus". Tanks contain the required swash partitions and removable gasketed top for ease of filling, cleaning and inspection.

The foam proportioning trailer contains a positive displacement foam concentrate pump which is driven by an air cooled diesel engine complete with electric start. The pump is constructed of materials compatible with all types of fire fighting foam concentrates and can be designed for use with 1%, 3%, or 6% ATC or AFFF foam concentrates. The in-line balance pressure proportioning systems maintains an equal pressure in the foam concentrate and water inlets to the proportioner. This allows the system to be used over a wide range of flow rates and available pressures. A duplex pressure gauge provides a reading of the foam concentrate and water pressure.

APPLICATION

The Perimeter Solutions Foam Proportioning Trailer is designed to provide quick, mobile foam fire protection for

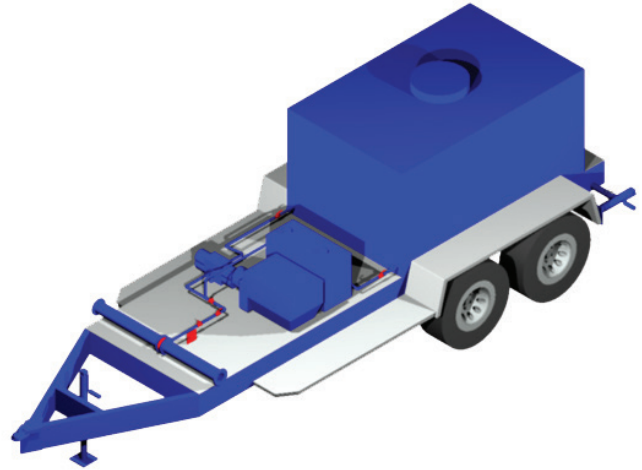

hazards consisting of flammable liquids. These types of hazards can be defined as tank farms, loading racks (both truck and rail), chemical processing plants, and marine off loading/on loading terminals. The trailer storage vessel provides a large capacity supply of foam concentrate.

The Solberg Foam Proportioning Trailer greatly increases the fire fighting ability of industrial, municipal, and military fire emergency responders.

SPECIFICATIONS

Proportioning System

The balanced pressure proportioning system shall contain all required components including; in-line foam proportioner, pressure balancing valve, gauge (duplex), drain, check and control valves, valve identification nameplates, and interconnecting pipe (brass). Balancing of the proportioning system shall be accomplished through the use of a pressure balancing valve. The valve shall sense water inlet pressure and foam concentrate pressure and shall adjust to pressure changes on the foam supply port of the proportioner. The pressure balancing valve shall be constructed of brass, containing all necessary O-rings and seals. The interconnecting piping for foam concentrate shall be of brass construction. The balanced pressure proportioner shall be completely pressure tested.

Trailer Frame

The trailer frame shall be constructed of all welded steel. No bolts, screws, or rivets shall be used in the construction of the frame. The trailer framework shall be constructed of 4.0" x 2.0" x 0.125" (102 mm x 51mm x 3.2 mm) wall steel tubing. The cross members shall be notched at their ends to fit inside of the outer frame channels. Cross members shall be positioned to maximize support for the foam tank, monitors, and plumbing. Two lengths of 4.0" (102 mm) channel shall be welded diagonally between

FOAM PROPORTIONING TRAILER

the coupler and the front corners of the frame. The front of the trailer (monitor operators position), shall be covered with 0.125" (3.2 mm) embossed aluminum diamond plate. Mounting provisions shall be provided for the foam tank(s). The trailer shall be equipped with 2-5/16" (59 mm) coupler, adjustable front jack, two rear stabilizer jacks, and full light package for highway use.

Storage Tank

The metal foam storage tank shall be sized to hold 500, 750, or 1000 gallons (1893, 2839, or 3785 liters) of foam concentrate. The metal tank shall be constructed of painted steel or stainless steel of sufficient gauge.

Foam Tank

Connection Foam connection hoses shall be constructed of 2.0" (50 mm) clear suction hose to allow visual confirmation of foam flow. Cam and groove couplings shall be used to enable quick connection and disconnection of the foam concentrate hoses.

Axles

The axles shall be rated a minimum of 3500 lb (1588 kg) load rating each. The axles shall be bolted to the frame utilizing Grade 8 bolts. The axles shall consist of torsion bar suspension and independent wheel movement to provide maximum shock absorption and proper handling.

Brakes

The trailer assembly shall contain an electric brake system.

NFPA Lighting Package (optional):

The trailer shall contain a light package that meets the minimum warning light and actuation requirements of NFPA 1901 Fire Apparatus Standard (current version).

Finish

The trailer shall be painted with red or blue enamel paint finish.

OPTIONS

Contact Perimeter Solutions Technical Services for options on proportioners, hoses, and other trailer equipment.

DIMENSIONAL INFORMATION

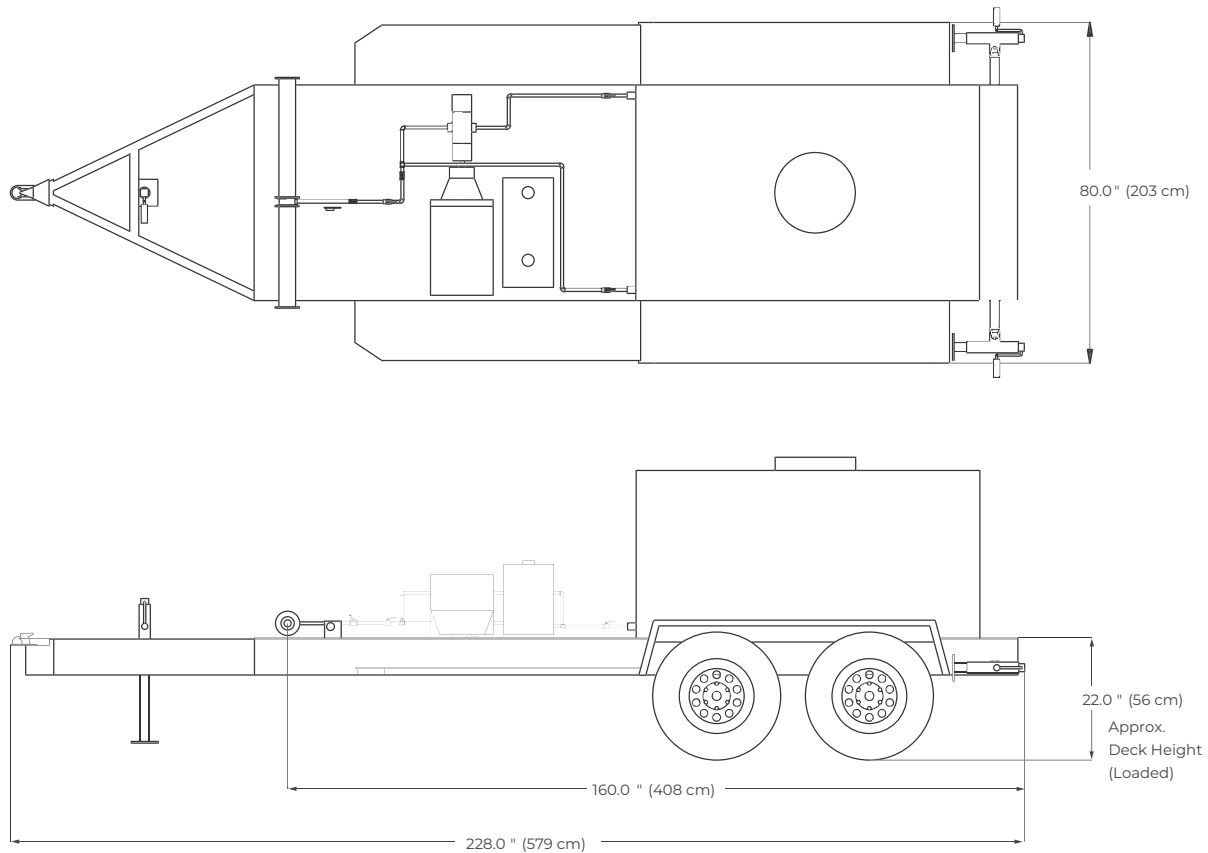

Note: Dimensions are approximates and will vary depending on model and options selected.

FOAM PROPORTIONING TRAILER

ORDERING INFORMATION

Contact Perimeter Solutions Sales or Technical Services Department for options, pricing and delivery.



Solutions That Save.

FOR MORE INFORMATION

Contact any of our worldwide Perimeter Solutions Fire Safety offices or visit:

www.Perimeter-Solutions.com

UNITED STATES

10667 Jersey Blvd.
Rancho Cucamonga, CA 91730

Tel: +1 800 682 3626

Tel: +1 909 983 0772

salesfoamusa@perimeter-solutions.com

EMEA

Polígono de Baiña, Parcela 23
33682 Mieres (Asturias)

Spain

Tel: +34 985 24 29 45

salesfoamemea@perimeter-solutions.com

ASIA PACIFIC

3 Charles Street
St Marys NSW 2760 – Australia

Tel: +61 2 9673 5300

salesfoamapac@perimeter-solutions.com

perimeter-solutions.com

NOTICE PERIMETER SOLUTIONS MAKES NO REPRESENTATIONS OR WARRANTIES AS TO THE COMPLETENESS OR ACCURACY OF THE INFORMATION INCLUDED HEREIN. THE INFORMATION CONTAINED HEREIN IS NOT INTENDED TO PROVIDE REGULATORY, LEGAL OR EXPERT ADVICE RELATING TO THE PRODUCTS, ITS APPLICATION OR USES. NOTHING CONTAINED HEREIN IS TO BE CONSTRUED AS A RECOMMENDATION TO USE ANY PRODUCT, PROCESS, EQUIPMENT OR FORMULATION IN CONFLICT WITH ANY INDUSTRIAL PROPERTY OR INTELLECTUAL PROPERTY RIGHTS, AND PERIMETER SOLUTIONS MAKES NO REPRESENTATION OR WARRANTY, EXPRESS OR IMPLIED, THAT THE USE THEREOF WILL NOT INFRINGE ON ANY INDUSTRIAL PROPERTY OR INTELLECTUAL PROPERTY RIGHTS. NO REPRESENTATIONS OR WARRANTIES, EITHER EXPRESSED OR IMPLIED, OF MERCHANTABILITY, FITNESS FOR A PARTICULAR PURPOSE OR OF ANY OTHER NATURE ARE MADE HEREUNDER WITH RESPECT TO THE INFORMATION CONTAINED HEREIN.

TWIN-AGENT UNIT 100/30

FEATURES

- Dual agent fire extinguishing capability
- 100 lb (45 kg) Purple-K dry chemical
- 30 gallon (114 litres) pre-mix AR-AFFF foam solution
- Compact design
- One person operation
- Suitable for high-hazard, high-risk applications
- Available with or without skid foot mount

DESCRIPTION

The Perimeter Solutions Twin-Agent Unit is designed and constructed for oneperson operation. This mobile or fixed firefighting unit can function at its full potential quickly in an emergency situation.

The 100/30 Twin-Agent Unit (TAU) consists of two agent tanks, twin 50 ft (15.2 m) hose and single nitrogen cylinder with regulator assembly to control the pressure flow of gas into the agent tank assemblies. The 100/30 TAU is mounted on a skid frame base for ease of lifting and moving.

APPLICATION

The Perimeter Solutions 100/30 Twin-Agent Unit is designed to provide firefighting capabilities in industrial or multiple hazard areas containing Class B fuels. Common high-hazard high-risk areas include:

- Flammable liquid storage
- Fueling stations
- Loading racks
- Docks/jetties
- Mining operations
- Parking garages
- Processing areas
- Rapid intervention vehicles

PERFORMANCE

The Perimeter Solutions 100/30 TAU is a highperformance firefighting unit capable of extinguishing Class B hydrocarbon and polar solvent fuel fires. Requiring only a single operator for use, this compact unit requires 32 ft³ (0.92 m³) of storage space and is capable of extinguishing at least 200 - 300 ft² (19.0 - 28.0 m²) of flammable/ combustible liquid spill area.

The combined twin-agent unit provides extinguishing capability not found with single-agent type units. PURPLE-K dry chemical contains specially fluidized and siliconized potassium bicarbonate dry chemical which is 2.5 times more effective than regular dry chemical on Class B flammable/combustible liquids (fuel-in-depth,



spill fires) and pressurized gases. It is electrically non-conductive. ARCTIC 3x3% ATC pre-mix foam solution can be applied to hydrocarbon and polar solvent fuel fires. The foam solution can be used to prevent ignition or re-ignition of liquid spills and to control hazardous vapors. When used as a twin-agent combination, fuel-in-depth, spill, threedimensional and pressurized fires are easily extinguished.

COMPONENTS

The SOLBERG Twin-Agent Unit is a self-contained unit consisting of 100 pounds (45 kg) of AMEREX PURPLE-K dry chemical and 30 gallons (114 litres) of SOLBERG® ARCTIC 3x3% ATC premix solution.

Agent tank assemblies are each equipped with a safety relief valve. A single 110 ft³ (3.11 m³) nitrogen cylinder is used to expel both agents through 50 ft (15 m) of twinned hose connected to the dual agent nozzle. The dry chemical and foam nozzles are mechanically linked and can be operated independently or simultaneously. Each nozzle consists of a bail type slide-valve.

The dry chemical nozzle is designed for an application rate of 5 lbs per second (2.3 kg/s). The nozzle operator can select from six valve settings for an appropriate flow rate of dry chemical agent up to the maximum flow of the system. The foam nozzle features fully automatic pressure control, regulated to approximately 100 psi (6.9 bar) throughout the flow range from 10 to 125 gpm (8.4 to 105 l/min). The nozzle design allows for an adjustable pattern. The effective range of the twin agent unit is 30 ft (9 m) at full flow and proportionately less at lower valve settings.

The Perimeter Solutions 100/30 TAU is actuated by manually opening the lever operated quick-opening nitrogen cylinder valve.

TWIN-AGENT UNIT 100/30

OPTIONS

- Stainless steel tanks
- Vinyl cover.

The system is designed with sufficient nitrogen and a suitable valving arrangement so that the hose lines and nozzles can be completely cleared of agent after discharge without discharging any agent remaining in the tanks.

SPECIFICATIONS

The agent tanks are manufactured in compliance with ASME Code Section VI 11 Division 1 with a 250 psi (17 bar) rating, tested to 375 psi (26 bar), or 1.5 times the working pressure. The tanks are constructed out of SA 516 Grade 70 carbon steel. The interior of the foam tank is coated with a coal tar epoxy.

Dry Chemical - The potassium bicarbonate dry chemical shall be tested for use with this system and shall meet the requirements of Underwriters Laboratories.

Firefighting Foam - The foam solution for this unit shall be ARCTIC 3x3% ATC AR-AFFF pre-mix.

Note: The approximate fully charged weight of the unit is 960 lb (435 kg).

DIMENSIONAL INFORMATION

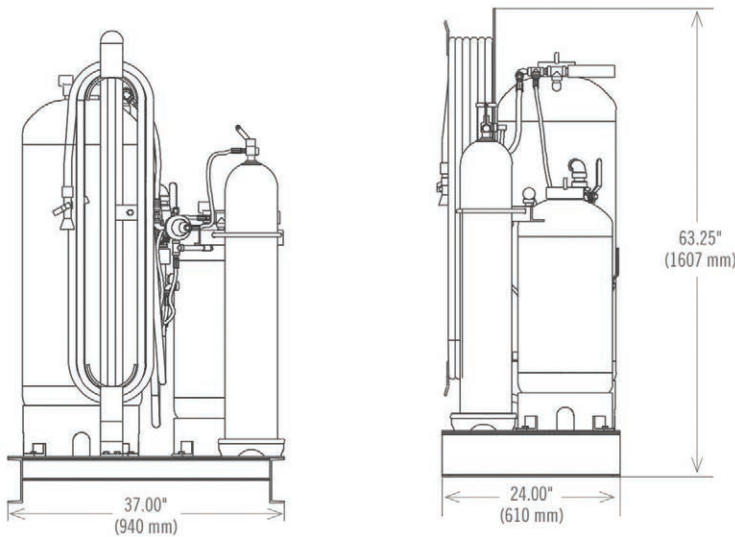

ORDERING INFORMATION

Twin-Agent Unit		APPROXIMATE SHIPPING WEIGHT	
PART NO.	DESCRIPTION	lb	kg
41000	Twin-Agent Unit, 100/30, Purple-K Dry Chemical, 3x3% AR-AFFF Pre-Mix Foam	585	265



Solutions That Save.

FOR MORE INFORMATION

Contact any of our worldwide Perimeter Solutions Fire Safety offices or visit:

www.Perimeter-Solutions.com

UNITED STATES

10667 Jersey Blvd.
 Rancho Cucamonga, CA 91730
 Tel: +1 800 682 3626
 Tel: +1 909 983 0772
salesfoamusa@perimeter-solutions.com

EMEA

Polígono de Baiña, Parcela 23
 33682 Mieres (Asturias)
 Spain
 Tel: +34 985 24 29 45
salesfoamemea@perimeter-solutions.com

ASIA PACIFIC

3 Charles Street
 St Marys NSW 2760 – Australia
 Tel: +61 2 9673 5300
salesfoamapac@perimeter-solutions.com

perimeter-solutions.com

NOTICE PERIMETER SOLUTIONS MAKES NO REPRESENTATIONS OR WARRANTIES AS TO THE COMPLETENESS OR ACCURACY OF THE INFORMATION INCLUDED HEREIN. THE INFORMATION CONTAINED HEREIN IS NOT INTENDED TO PROVIDE REGULATORY, LEGAL OR EXPERT ADVICE RELATING TO THE PRODUCTS, ITS APPLICATION OR USES. NOTHING CONTAINED HEREIN IS TO BE CONSTRUED AS A RECOMMENDATION TO USE ANY PRODUCT, PROCESS, EQUIPMENT OR FORMULATION IN CONFLICT WITH ANY INDUSTRIAL PROPERTY OR INTELLECTUAL PROPERTY RIGHTS, AND PERIMETER SOLUTIONS MAKES NO REPRESENTATION OR WARRANTY, EXPRESS OR IMPLIED, THAT THE USE THEREOF WILL NOT INFRINGE ON ANY INDUSTRIAL PROPERTY OR INTELLECTUAL PROPERTY RIGHTS. NO REPRESENTATIONS OR WARRANTIES, EITHER EXPRESSED OR IMPLIED, OF MERCHANTABILITY, FITNESS FOR A PARTICULAR PURPOSE OR OF ANY OTHER NATURE ARE MADE HEREUNDER WITH RESPECT TO THE INFORMATION CONTAINED HEREIN.

The background features a vibrant color gradient from yellow-orange on the left to deep red on the right. Overlaid on this are several large, semi-transparent geometric shapes: a large rounded triangle pointing upwards on the right side, and various overlapping trapezoidal and triangular shapes in shades of orange and red, creating a layered, architectural effect.

SECTION 6 APPLICATIONS

Introduction

This section covers foam system requirements for some of the common type hazards:

Section 6.1 – Aircraft Hangar Protection (NFPA 409)

Section 6.2 – Diked Area/Spill Protection (NFPA 11)

Section 6.3 – Foam/Water Sprinkler Systems (NFPA 16, 30)

Section 6.4 – Heliport Protection (NFPA 418)

Section 6.5 – High Expansion Foam Systems (NFPA 11)

Section 6.6 – Loading Rack Protection (NFPA 11)

Section 6.7 – Storage Tank Protection (NFPA 11, 30)

Detailed design and system requirements are stated in the NFPA Standards for each type hazard. System designers should be familiar with the required standards.

Detection and control systems are also required. Contact your local Solberg representative.

See Section 7 – Appendix, for foam glossary, piping charts, friction loss tables, comparison of proportioning types, and various other design charts.

SECTION 6.1

APPLICATIONS

Aircraft Hangar Protection

SECTION 6.1 - Aircraft Hangar Protection (NFPA 409)

There are four Groups (Classifications) of aircraft hangars. The classification must be determined so that the type of fire protection requirements can be defined. NFPA 409 defines these groups as:

Group I

A hangar with at least one of the following conditions:

- An aircraft access door height over 28 ft (8.5 m)
- A single fire area in excess of 40,000 sq. ft (12,192 m)
- Housing an aircraft with a tail height over 28 ft (8.5 m)
- Housing strategic military aircraft as determined by the Dept. of Defense



Group II

A hangar with both of the following conditions:

- An aircraft access door height of 28 ft (8.5 m) or less
- A single fire area not larger than 40,000 sq ft (12,192 m), but equal to or greater than those specified in NFPA 409, Table 4.1.2 for specific types of construction

Group III

This type hangar may be a freestanding individual unit for a single aircraft, a row hangar having a common structural wall and roof system and housing multiple aircraft as well as having door openings for each aircraft, or an open bay hangar capable of housing multiple aircraft, and having both of the following conditions:

- An aircraft access door height of less than 28 ft (8.5 m)
- A single fire area up to the maximum permitted for specific types of construction as defined in NFPA 409, Table 4.1.3

Group IV

This is a membrane-covered, rigid, steel frame structure.

Protection Options

There are four types of protection options available for aircraft hangars:

- Overhead Foam/water Sprinkler Systems
- Foam Monitor Systems
- Foam Hand Hose Line Systems (Secondary)
- High Expansion Foam Systems

SECTION 6.1 – APPLICATIONS

Group I Hangar Protection

Three options are available for protecting Group I Aircraft Hangars.

Option 1: A foam-water overhead deluge system is required for primary protection. If the hangar has aircraft with wing areas greater than 3,000 sq ft (279 sq m) a supplementary protection system consisting of a low-level oscillating monitor system is to be provided. This system should cover the floor area beneath the aircraft being protected. Systems shall be designed for 10 minute operation. The monitor system must have a minimum design density of 0.16 gpm/ft² (6.5 lpm/m²) when using protein or fluor-protein foam concentrate and 0.10 gpm/ft² (4.1 lpm/m²) when using AFFF.

Option 2: A combination of a closed-head water sprinkler system and an automatic low-level low expansion foam system.

Option 3: A combination of a closed-head water sprinkler system and an automatic low level, high expansion foam system.

Note: The water sprinkler system for Group I hangars must be designed for 0.17 gpm/ft² (6.9 lpm/m²) over any 15,000 sq ft (1393.5 sq m) area. Foam-water hand hose systems must be installed if the aircraft DOES NOT have drained and purged fuel tanks.

Group II Hangar Protection

Option 1: In accordance with the requirements for a Group I Hangar.

Option 2: A combination of a closed-head water sprinkler system AND an automatic low-level low expansion foam system.

Option 3: A combination of a closed-head water sprinkler system AND an automatic high expansion foam system.

Option 4: A closed-head foam-water sprinkler system.

Group III Hangar Protection

Fixed fire protection systems are normally not required. If any hazardous operations, such as fuel transfer, welding, painting, touch cutting, etc, are performed in a Group III hangar, the hangar must be protected as a Group II Hangar.

Group IV Hangar Protection

Option 1: A low expansion foam system providing 0.10 gpm/sq ft (4.0 lpm/sq m) over the entire storage and service area.

Option 2: A high expansion foam system providing 3 cu ft/min. per sq ft (0.8 cu m/min per 0.1 sq m) over the entire storage and service areas.

Option 3: An automatic water sprinkler system meeting the following requirements:

- Close-head sprinkler meeting NFPA 13
- Quick response water sprinkler heads
- A design application rate of 0.17 gpm/ft² (6.9 lpm/m²)

A connected reserve supply of concentrate in a separate, manually-operated tank is required per NFPA 409. However, the AHJ may give an exception if a supply of concentrate is available with 24 hours. This does not include hand hose line systems.

In addition, hand portables and wheeled extinguishers must be provided in all hangars per the requirements of NFPA 10.

Determine Monitor System Discharge Time And Application Rates

Each supplementary fixed foam system is to be designed to cover a specific floor area within 30 seconds of activation and to extinguish any fire within 60 seconds. The specified floor area is the area under the wings and center section of the aircraft. The different configuration of aircraft and their position within the hangar must be considered for effective fire protection when positioning of the monitors.

If more than one aircraft is located within any drainage system, it is recommended that the supplementary foam monitor system be capable of effectively covering the complete floor beneath all aircraft.

Minimum flow rates through supplementary monitor systems for the area of coverage is to be 0.10 gpm/sq ft. (4.1 lpm/m²) when using AFFF concentrates.

It is recommended that a control valve be installed at the base of each oscillating monitor or fixed nozzle system.

The discharge time for monitor systems is 10 minutes.

To calculate the monitor system foam quantity required, first, use the following formula to determine the foam solution discharge rate for each monitor to select the proper monitor and nozzle:

$$\text{Foam solution discharge rate} = \text{Area of coverage} \times \text{application rate.}$$

Next, determine the total foam solution discharge rate which is the combination of the discharge rates of all the monitors. This is required to determine the size of the proportioner required.

$$\text{Total foam solution discharge rate} = \text{monitor \#1 discharge rate} + \text{monitor \#2 discharge rate} + \text{remaining monitor's discharge rate}$$

Then, calculate the foam concentrate quantity using the following formula:

$$\text{Total foam quantity} = \frac{\text{Total foam solution discharge rate} \times 10 \text{ minutes} \times \text{concentrate \%}^*}{1.15 \text{ (15\% overage)}}$$

** Concentrate% is shown as: 0.01 for 1%, 0.03 for 3%, and 0.06 for 6%*

Determine Hand Line System Discharge Time And Application Rates

Provisions are to be made in water flow calculations for operating a minimum of two foam hand hose line systems. Each system must have a minimum flow rate of 60 gpm (227 lpm) at sufficient nozzle pressure with a foam solution discharge duration of 20 minutes.

Use the following formula to calculate the quantity of foam concentrate required:

$$\text{Quantity required} = \text{foam solution discharge rate} \times 20 \text{ minutes} \times \text{concentrate \%}^*$$

** Concentrate% is shown as: 0.01 for 1%, 0.03 for 3%, and 0.06 for 6%*

The supply for the hand hose lines may be incorporated into the primary system supply and connected to the sprinkler system header. It can also have a separate supply for hand hose lines so that the primary system does not require recharge when only the hand hose lines are used.

Aircraft Hangar Monitor Protection

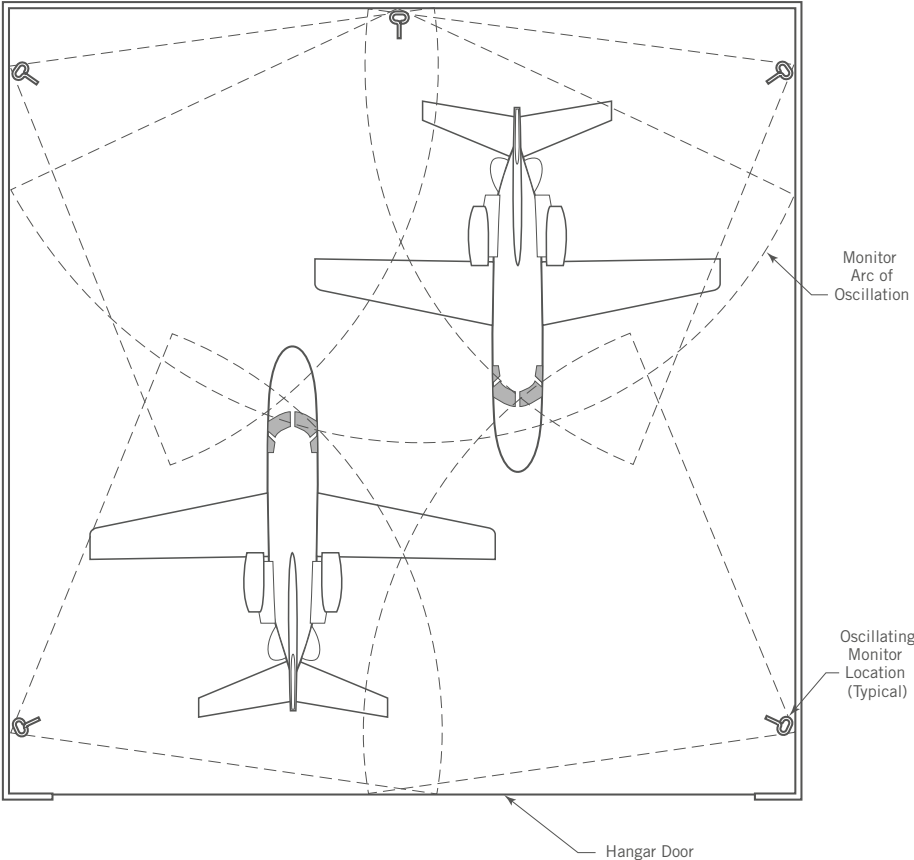

The background features a gradient from yellow-orange on the left to red on the right. Large, semi-transparent geometric shapes, including a large triangle and a rounded rectangle, are layered across the background.

SECTION 6.2

APPLICATIONS

Diked Area/Spill Protection

Section 6.2 - Dike Area/Spill Protection (NFPA 11)

A diked area is the area surrounded by physical barriers that retain the spilled fuel to a depth of 1 in. (2.5 cm) or more. In many locations, the flammable liquids are stored in tanks which are located within a common diked area. Protection of the diked area can be achieved by using:

- Low-level fixed mounted foam makers
- Monitors (Located outside the diked area)
- Foam-water spray nozzles over the hazard area
- Foam sprinkler system over the hazard area
- Supplementary protection utilizing portable foam application equipment should also be available



If the diked area is located outdoors, additional consideration should be made during the design when using either a monitor or foam/water sprinkler system. Wind and rain can affect the performance of these systems. It may be necessary to increase the application rate to compensate for these conditions. If the diked area has obstructions that could impede the performance of an overhead or monitor system, supplementary low level foam discharge devices may be required.

Minimum Application Rates and Discharge Times for Fixed Foam Application on Diked Areas Involving Hydrocarbon Liquids (Per NFPA 11)

Type of Foam Discharge Outlet	Minimum Application Rate	Minimum Discharge Time – Class I Hydrocarbon	Minimum Discharge Time – Class II Hydrocarbon
Low-level foam discharge outlet	0.10 gpm/sq ft (4.1 lpm/sq m)	30 minutes	20 minutes
Foam monitors	0.16 gpm/sq ft. (6.5 lpm/sq m)	30 minutes	20 minutes

For flammable liquids requiring AR-AFFF type foam concentrate, the discharge time shall be a minimum of 30 minutes (per NFPA 11).

If an overhead foam-water sprinkler system is used, it should be designed per NFPA 16: “Installation of Foam-Water Sprinkler and Foam-Water Spray Systems”. The application rate for AFFF on hydrocarbon fuels is 0.16 gpm/sq ft (6.5 lpm/sq m) for a period of at least 10 minutes. On fuels that are polar solvents, the application rate may have to be greater.

Monitor Protection

Permanently mounted monitors will provide a flexible design for the protection of diked areas. The monitors can be manually operated, automatically operated (oscillating), or remote controlled. Because the foam discharge can be directed to any point of the diked area, it is possible to apply foam to the entire dike area during a large spill. It is also possible to apply foam to smaller areas, such as pumps, pipe flanges, or leaking valves/fittings.

SECTION 6.2 – APPLICATIONS

When designing the monitor system, consideration must be given to the size, placement, and number of monitors required. Based on Solberg monitors flow rate and discharge ranges, select the monitors that provide the required coverages. When determining the monitor(s) required, consider the effects of wind and adverse weather conditions.

Additional, properly sized monitors can be used to protect storage tanks located within the dike area. Keep in mind that these tanks can not exceed 60 ft (18 m) in diameter.

The foam concentrate supply shall be adequate to protect the entire diked area, at the required application flow rate and discharge time.

Foam Maker Fixed Discharge Protection

When utilizing fixed foam makers for diked area protection, the maximum recommended spacing between discharge outlets is 30 ft (9.1 m) at 60 gpm (227 lpm) flow rate or less. For flow rates that are greater than 60 gpm (227 lpm), spacing can be increased to a maximum of 60 ft (18.3 m).

Example:

Three storage tanks (containing Class 2 fuel) are located within a diked area of 80 ft (24.4 m) x 80 ft 924.4 m).

- Area of diked surface: 80 ft x 80 ft = 6400 sq ft (595 sq m). Note: Tanks diameter cannot be deducted from diked area.
- Class I fuel requires minimum application rate of 0.10 gpm/sq ft (4.1 lpm/sq m) and a minimum discharge time of 30 minutes.

- Determine the required foam solution discharge rate:

$$6400 \text{ sq ft (595 sq m) (diked area) } \times 0.10 \text{ gpm/sq ft (4.1 lpm/sq m) } = 640 \text{ gpm (2423 lpm) total discharge flow rate.}$$

- Determine the quantity of foam concentrate required:

$$640 \text{ gpm } \times 30 \text{ minutes } \times 0.03 \text{ (3\% concentrate) } = 576 \text{ gallon (2180 l) of concentrate required}$$

- Determine the number of fixed foam makers required:

In this example, a high flow Solberg foam maker has been chosen. This model has a 90 gpm (341 lpm) rating at 40 psi (3 bar). Because the discharge rate is greater than 60 gpm, the maker spacing can be increased to 60 ft (18.3 m) apart.

Based on a maximum spacing of 60 ft. (18.3 m) along the diked wall, the hazard would require 6 foam makers.

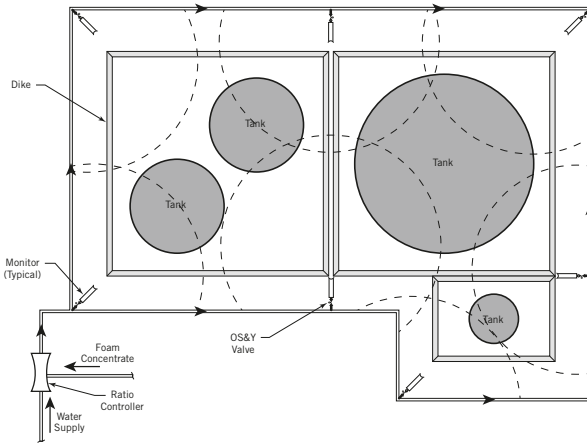
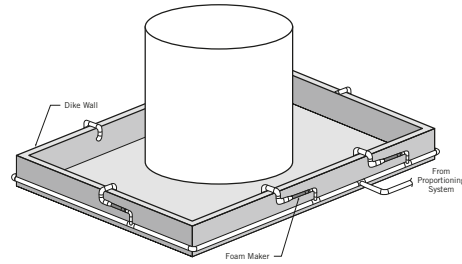
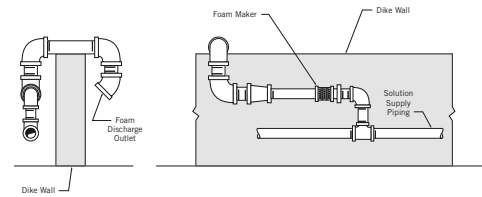
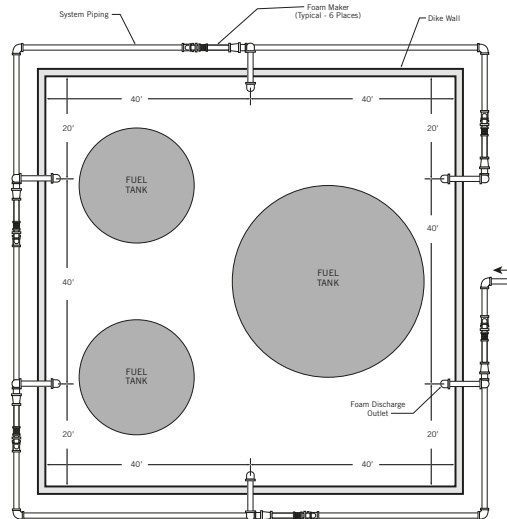
Tank & Dike Protection with Foam Monitor System

Typical Dike Protection

Typical Dike Area Foam Maker Installation

Typical Fixed Foam Maker Layout for Diked Area



SECTION 6.3

APPLICATIONS

Foam-Water Sprinkler Systems

Section 6.3 - Foam-Water Sprinkler Systems (Warehouse/Storage Area) (NFPA 16, 30)

Protection for warehousing/storage facilities can be accomplished utilizing a Foam-Water Sprinkler System, either closed head or open head/deluge.

NFPA 16 states: “The design density shall be in accordance with the applicable occupancy standard for water or foam-water systems but in no case less than 0.16 gpm/sq ft (6.5 lpm/sq m). The foam solution shall be designed to discharge for a period of 10 minutes over the entire system area for deluge and spray foam-water systems and over the design area for wet pipe, dry pipe, and pre-action foam-water systems.”

However, when utilizing a closed-head foam-water system, the AHJ may require an application rate in excess of 0.16 gpm/sq ft over a specific area. Application rates ranging from 0.20 to 0.40 gpm/sq ft (8.1 to 16.3 lpm/sq m) are often used. Before the final sizing of the foam system, determine with the AHJ what areas will require a higher design density. For example, and insurance carrier may require an application rate of 0.30 gpm/sq ft (12.2 lpm/sq m) over 1,500 sq ft (457 sq m) depending on the type of sprinkler head used. NFPA 30 requires 0.30 gpm/sq ft (12.2 lpm/sq m) application rate over 3,000 sq ft (279 sq m) when using quick response or standard response 286°F (141°C) temperature sprinkler heads.



Discharge Duration

- NFPA 16 requires a discharge time of 10 minutes
- NFPA 30 requires a discharge time of 15 minutes
- The local “AHJ” may require a discharge time of 20 minutes

Sizing The Foam System

The area being protected must first be determined to correctly size the foam system. The area can vary depending which NFPA standard or AHJ requirements are followed. NFPA 16 requires that foam flow over the entire risk area if less than 5,000 sq ft (465 sq m) NFPA 16 also requires that the system demand area be based on 5,000 sq ft (465 sq m) unless occupancy standards specify a different demand area. NFPA 30 requires the system design be based on 3,000 sq ft (279 sq m) when used to protect solid pile or palletized storage of flammable liquids. If the system is to include an in-rack foam-water sprinkler system, the design criteria for foam-water sprinkler protection for single-, double-, or multiple-row rack storage of liquids in metal containers, portable tanks or IBC's shall be in accordance with NFPA 30, “Flammable and Combustible Liquid Codes,” Section 16.5.2 and corresponding Tables 16.5.2.1 through 16.5.2.5. In-rack sprinkler design is based on the six (6) most hydraulically remote sprinklers in each of the upper three (3) levels. Design area can be reduced to 1500 sq ft (457 sq m) when using a pre-primed foam-water system installed in accordance with NFPA 16, “Installation of Foam-Water Spray Systems.”

SECTION 6.3 – APPLICATIONS

Design Example – Deluge System

Type of System: Deluge foam-water sprinkler system

Design Standard Followed: NFPA 16

Size of Protected Area: 100 ft x 60 ft = 6,000 sq ft (30.5 m x 18.3 m = 558.2 sq m)

Hazard Material: Hydrocarbon liquids

Type of Foam Concentrate Used: 3% AFFF

Application Rate: 0.16 gpm/sq ft (6.5 lpm/sq m)

GPM Flow Rate of Foam Solution: 0.16 gpm/sq ft (6.5 lpm/sq m) x 6,000 sq ft (557 sq m) area = 960 gpm (3,634 lpm)

Duration of Discharge = 10 minutes...960 x 10 (min.) = 9,600 gallons (36,340 l) of foam solution

Foam Concentrate Required = 9,600 gal x 0.03 = 288 gallons (36340 l x 0.03 = 1090 l)

Number of Sprinkler Heads Required: 6,000 sq ft (557 sq. m) divided by 100 sq ft (9.3 sq m) per head =
a minimum of 60 heads required

Design Example – Wet Pipe System

Type of System: Wet Pipe

Design Standard Followed: NFPA 30

Size of Protected Area: 100 ft x 60 ft = 6,000 sq ft (30.5 m x 18.3 m = 558 sq m)

Hazard Material: Polar solvent and hydrocarbon liquids

Type of Foam Concentrate Used: 3x3 ATC

Application Rate: 0.30 gpm/sq ft (12.2 lpm/sq m)

GPM Flow Rate of Foam Solution: 0.30 gpm/sq ft (12.2 lpm/sq m) x 3,000 sq ft (279 sq m) area = 900 gpm (3407 lpm)

Duration of Discharge = 15 minutes...900 gpm x 15 (min.) = 13,500 gallons (51,103 l) of foam solution

Foam Concentrate Required = 13,500 gal x 0.03 = 405 gallons (1533 l)



The background features a gradient from yellow-orange on the left to red on the right. Large, semi-transparent geometric shapes, including a large triangle and a rounded rectangle, are layered across the page in various shades of red and orange.

SECTION 6.4

APPLICATIONS

Heliport Protection

Section 6.4 – Heliport Protection (NFPA 418)

Fire protection for heliports consists of foam system design using hand hose lines, oscillating foam monitors or fixed nozzle systems.

Heliports may be land based, on marine vessels or on offshore drilling rigs. The requirements for marine vessels and offshore drilling rigs are determined by the USCG, ABS, and EMEA rules. These rules differ from the requirements for land based heliports.

The type of protection recommended is determined by the “practical critical fire area”. This is determined by factors such as aircraft size, fuel capacity, passenger load, etc. NFPA 418 lists three categories of heliports:



H-1 HELIPORTS: Helicopter overall length* up to, but not including, 50 ft (15.3 m) with a practical critical fire area of 375 sq ft (34.8 sq m)

H-2 HELIPORTS: Helicopter overall length* from 50 ft (15.3 m) up to, but not including, 80 ft (24.4 m) with a practical critical fire area of 840 sq ft (78.0 sq m).

H-3 HELIPORTS: Helicopter overall length* from 80 ft (24.4 m) up to, but not including, 120 ft (36.6 m) with a practical critical fire area of 1,440 sq ft (133.8 sq m).

**Helicopter length, including the tail boom and the rotors.*

NFPA 418 requires a low expansion foam system be installed for all roof top heliports. NFPA recognizes two types of heliport protection: The first is foam hand hose lines which can be either a portable installation using an eductor or it can also be a permanently installed proportioning system piped to hose reels.

The second method is a fixed proportioning system permanently piped to monitors or fixed spray nozzles strategically located around the perimeter or in-deck nozzles within the perimeter.

Exception: Heliports on parking garages, unoccupied buildings or other similar unoccupied structures do not require the installation of a low expansion foam system. Also, for H-1 heliports, two portable foam extinguishers, each having a rating of 20A:160B shall be permitted to satisfy the requirement.

Foam Handline Requirements

The foam system design is based on the protection of the Practical Critical Fire Area (PCFA) of the largest helicopter that will use the heliport. NFPA 418 has established the size of the PCFA for each heliport category based on the largest helicopter that may use the heliport. The size of the practical critical fire area is as follows:

H-1 Category 375 sq ft (34.8 sq m)

H-2 Category 840 sq ft (78.0 sq m)

H-3 Category 1,440 sq ft (133.8 sq m)

SECTION 6.4 – APPLICATIONS

The foam application rate for AFFF concentrates is 0.1 gpm/sq ft (4.1 lpm/sq m)

The quantity of foam concentrate required is based on two minutes of operation at 0.1 gpm/sq ft (4.1 lpm/sq m).

The two minute discharge is based on control of the PCFA within one minute plus a 100% reserve quantity for extinguishment. The water supply must be from a reliable source and shall be adequate to supply the system at the design rate for the minimum discharge time.

The number of hose lines required has not been defined by NFPA 418. The size and quantity of nozzles for the hose lines is based on the discharge rate required to apply the foam to the practical critical fire area at the specified application rate. After the required flow rate has been determined, select nozzles with flow rates that can be handled by one operator. Typical nozzle flow rates are 60, 95, 125 gpm (227, 360, 473 lpm).

System Design #1 – Hand Hoseline

- 1 Determine the category of the heliport
- 2 Choose the type of foam concentrate for the hazard
- 3 Determine the application flow rate
- 4 Determine the method of application
- 5 Determine the amount of foam solution required. Do this by multiplying the Practical Critical Fire Area (PCFA) by the application rate
- 6 Determine the size and number of discharge devices required
- 7 Determine the discharge time required
- 8 Determine the required quantity of foam concentrate
- 9 Determine the type of proportioning equipment required

The following is a design example based on the above 9 design steps.

Design Example #1 – Hand Hoseline

Hazard Type:	Heliport
Largest Helicopter:	100 ft. (30.5 m) overall length
Size of Heliport:	120 ft x 120 ft (36.6 x 36.6 m)
Foam Concentrate:	AFFF
Type of Protection:	Foam Hose lines
Available Water Supply:	1,600 gpm (6057 lpm) at 110 psi (110 bar)

1. Determine the Category of the Heliport

The largest helicopter has an overall length of 100 ft (30.5 m). Based on this size, the heliport would be classified as an H-3 category.

2. Choose the Type of Foam Concentrate for the Hazard

AFFF is chosen as it has the lowest application rate and is well suited for spill type fires.

3. Determine the Application Flow Rate

The foam application rate for AFFF concentrate is 0.1 gpm/sq ft (4.1 lpm/sq m).

4. Determine of Method of Application

Hose line protection has been specified.

5. Determine the Amount of Foam Solution Required

The area requiring protection is the practical critical fire area. Based on the H-3 category classification, the practical critical fire area would be 1,440 sq ft (133.8 sq m). The required application rate is 0.1 gpm/sq ft (4.1 lpm/sq m) as determined in Step 3.

1,440 sq ft (133.8 sq. m) practical critical fire area x 0.1 gpm/sq ft (4.1 lpm/sq m) = 144 gpm (545 lpm) of foam solution required.

6. Determine the Size and Number of Discharge Devices Required

Based on the required foam solution flow rate of 144 gpm (545 lpm), two standard nozzles with a flow rate of 95 gpm (360 lpm) are chosen.

7. Determine the Discharge Time Required

Based on the foam hose line protection, the required discharge time, Per NFPA, is 2 minutes.

8. Determine the Required Quantity of Foam Concentrate

Because the actual application flow rate is higher than the design rate, the actual flow would be used to calculate the required quantity of foam concentrate.

Solution rate x % of injection x time = foam concentrate required.

190 gpm (719 lpm) solution flow rate x 0.03 x 2 minutes = 12 gallons (45.4 l) of concentrate required.

9. Determine the Type of Proportioning Equipment Required

Any type of proportioning equipment can be used but due to the small size of the proportioning required, line proportioners or a small bladder tank would be the best choice.

Fixed Systems

In some applications, it may be advisable to install a fixed foam system. The Authority Having Jurisdiction (AHJ) or the lack of trained personnel to operate the foam hose lines may require the installation of a fixed system. The fixed foam system has the foam proportioning equipment permanently piped to fixed discharge devices.

The foam application rate for fixed systems is 0.1 gpm/sq ft (4.1 lpm/sq m), however, the area of application is the entire landing pad, not just the practical critical fire area. Also, the discharge time increases to 5 minutes.

The fixed installation may use fixed monitors, oscillating monitors or fixed foam spray nozzles to protect the area. The system design has not been defined by NFPA 418 other than the application rate, area, and required discharge time. The size, number and location of the discharge devices are determined by the designer. In addition to the size of the helicopter, other conditions, such as wind conditions, points of egress, approach and departure patterns must be considered. Also, the system discharge must cover all sides of the helicopter as there is no way to determine the origin of the fire. The number of discharge devices required is determined based on the flow of the device, range, and spray pattern.

SECTION 6.4 – APPLICATIONS

System Design #2 – Fixed Nozzle Discharge

- 1 Determine the category of the heliport
- 2 Choose the type of foam concentrate for the hazard
- 3 Determine the application flow rate
- 4 Determine the method of application
- 5 Determine the amount of foam solution required. Do this by multiplying the total landing pad area by the application rate
- 6 Determine the size and number of discharge devices required
- 7 Determine the discharge time required
- 8 Determine the required quantity of foam concentrate
- 9 Determine the type of proportioning equipment required

The following is a design example based on the above 9 design steps.

Design Example #2– Fixed Nozzle Discharge

Hazard Type:	Heliport
Largest Helicopter:	100 ft (30.5 m) overall length
Size of Heliport:	120 ft x 120 ft (36.6 x 36.6 m)
Foam Concentrate:	AFFF
Type of Protection:	Fixed nozzles
Available Water Supply:	1,600 gpm (6057 lpm) at 110 psi (110 bar)

1. Determine the Category of the Heliport

The largest helicopter has an overall length of 100 ft (30.5 m). Based on this size, the heliport would be classified as an H-3 category.

2. Choose the Type of Foam Concentrate for the Hazard

AFFF is chosen as it has the lowest application rate and is well suited for spill type fires.

3. Determine the Application Flow Rate

The foam application rate for AFFF concentrate is 0.1 gpm/sq ft (4.1 lpm/sq m).

4. Determine of Method of Application

Foam fixed nozzle protection has been specified.

5. Determine the Amount of Foam Solution Required

The area requiring protection is the total landing pad area. Based on a 120 ft x 120 ft (36.6 m x 36.6 m) landing pad, the total area is 14,400 sq ft (1,338 sq m). The application rate required is 0.1 gpm/sq ft (4.1 lpm/sq ft). The required application rate is 0.1 gpm/sq ft (4.1 lpm/sq m) as determined in Step 3.

14,400 sq ft. (1,338 sq m) total landing pad area x 0.1 gpm/sq ft (4.1 lpm/sq m) = 1,440 gpm (5,451 lpm) of foam solution required.

6. Determine the Size and Number of Discharge Devices Required

Based on the required foam solution flow rate of 1,440 gpm (5,451 lpm) and the maximum monitor spacing of 60 ft (18.3 m), this size hazard requires 6 nozzles, each with a minimum flow rate of 240 gpm (909 lpm).

7. Determine the Discharge Time Required

Based on the fixed discharge protection, the required discharge time, per NFPA, is 5 minutes of operation.

8. Determine the Required Quantity of Foam Concentrate

The actual flow rate is used to calculate the required quantity of foam concentrate.

Solution rate x % of injection x time = foam concentrate required.

1,440 gpm (5,451 lpm) solution flow rate x 0.03 x 5 minutes = 216 gallons (818 l) of concentrate required.

9. Determine the Type of Proportioning Equipment Required

Any type of proportioning equipment can be used but due to the small size of the proportioning required, line proportioners or a small bladder tank would be the best choice.

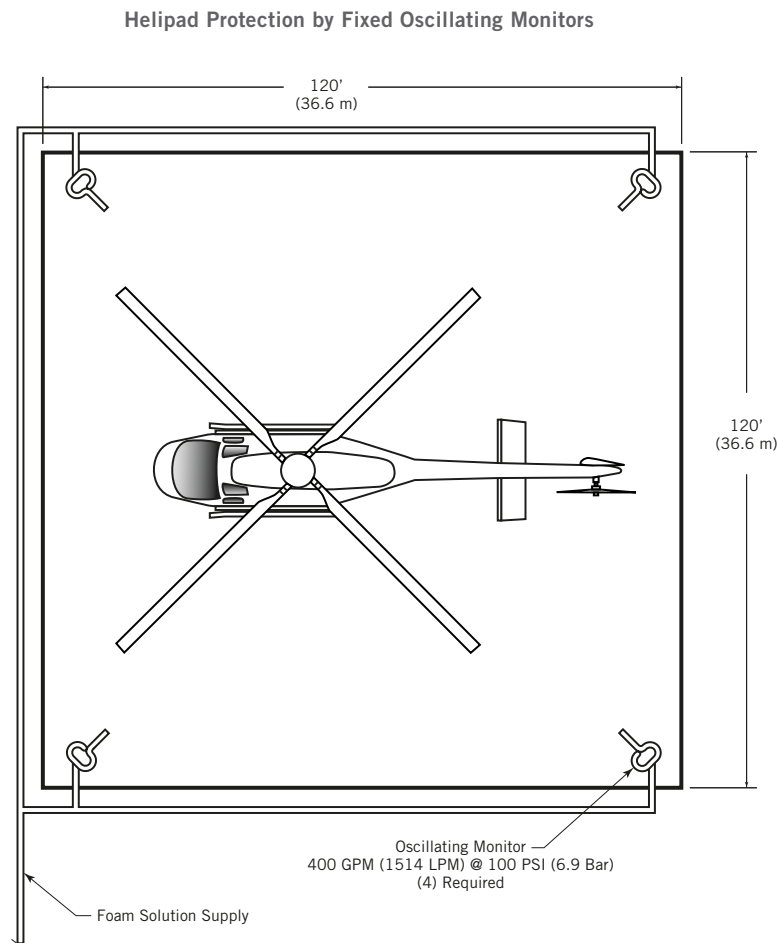

SECTION 6.5

APPLICATIONS

High Expansion Foam Systems

Section 6.5 – High Expansion Foam Systems (NFPA 11)

SECTION 6.6

APPLICATIONS

Loading Rack Protection

Section 6.6 – Loading Rack Protection (NFPA 11, 13, 16)

Two basic methods for protecting loading racks are available. One method uses foam-water sprinklers mounted in the rack canopy and sometimes supplemented by directional foam-water nozzles mounted at a lower level to discharge directly under the trucks. The second method utilizes foam monitors or foam hand hoselines.

Loading racks are normally surrounded by a low-profile diked area or a drainage system which will contain the fuel spill. If no dike is provided, the area under the canopy is to be considered the hazard area. However, the overall length of the truck being loaded may be longer than the canopy area, therefore, that additional area must be considered.



Foam-Water Sprinkler Systems

The foam-water sprinkler system should be designed to protect the canopy area, area of longer trucks, pumps, meters, and any other area associated with the loading and unloading operation.

The foam-water deluge sprinkler system may be designed using air-aspirating foam-water sprinklers or standard non air-aspirating sprinklers. Foam-water sprinkler systems should be designed to deliver a minimum of foam solution at a flow rate of 16 gpm (60.6 lpm) per head. The discharge duration is a minimum of 10 minutes at the specified application rate. The authority having jurisdiction may require a higher application rate or discharge time and should be consulted for final requirements.

In accordance with NFPA 16, the deluge foam-water sprinkler system can protect a maximum allowable coverage area per sprinkler of 100 sq ft (9.3 sq m). The design and installation of the sprinkler system, including spacing and location of the sprinkler over the area being protected must be in accordance with NFPA 13 for extra hazard occupancy. The sprinkler system must also be hydraulically calculated in accordance with the requirements of NFPA 13.

NFPA does not state guidelines for the placement of supplementary ground sweep nozzles. Typically, two nozzles are utilized per each bay. One can be located near the front wheels and the second one near the rear wheels for the tanker. Both nozzles should be directed to discharge under the tank area. Note: When using ground sweep nozzles, the flow from these should not be considered in the design of the overhead sprinkler system for determining the minimum application flow rate.

System Design

- 1 Determine the type and size of hazard
- 2 Determine the application flow rate
- 3 Determine the number of sprinklers required
- 4 Determine if ground sweep nozzles are required and quantity
- 5 Determine the total system discharge flow rate
- 6 Determine the water requirements
- 7 Determine the discharge time
- 8 Calculate the quantity of foam concentrate required
- 7 Determine the size and type of proportioning equipment required

Design Example

SECTION 6.6 – APPLICATIONS

Hazard Type:	Four bay loading rack
Curbed Area:	45 ft (13.7 m) wide by 90 ft (27.4 m) long
Type of Protection:	Deluge Foam-Water Sprinkler System
Number of Islands:	3
Canopy Size:	43 ft x 85 ft (13.1 m x 25.9 m)
Fuel Type:	Gasoline

1. Determine the Type and Size of Hazard

Hazard Type:	Four bay loading rack
Curbed Area:	45 ft (13.7 m) wide by 90 ft (27.4 m) long
Number of Islands:	3
Canopy Size:	43 ft x 85 ft (13.1 m x 25.9 m)
Fuel Type:	Gasoline

2. Determine the Application Flow Rate

Area to be protected is: 45 ft x 90 ft = 4,050 sq ft (13.7 m x 27.4 m = 375.4 sq m).

4,050 sq ft (13.7 sq m) x 0.16 gpm/sq ft (6.5 lpm/sq m) = 648 gpm (2453 lpm).

3. Determine the Number of Sprinklers Required

Number of sprinklers: 4,050 sq ft (376 sq m) divided by 100 sq ft (9.3 sq m) per sprinkler = 41 sprinklers.

4. Determine if Ground Sweep Nozzles Are Required and Quantity

If ground sweep nozzles are being provided (not required per NFPA), determine the quantity required.

Nozzles required = 2 nozzles per bay x 4 bays = 8 nozzles total.

5. Determine the Total System Discharge Flow Rate

The system should be hydraulically calculated in accordance with the procedure stated in NFPA 13. An estimate can be done as follows:

Sprinkler solution flow rate: 16 gpm (60.6 lpm) per sprinkler x 41 sprinklers = 656 gpm (2,485 lpm)

Nozzle solution flow rate: 16 gpm (60.6 lpm) x 8 nozzles = 128 gpm (484.5 lpm)

Total foam solution flow rate: 656 gpm (2,483 lpm) + 128 gpm (485 lpm) = 784 gpm (2,968 lpm)

6. Determine the Water Requirements

To determine the water flow requirements, multiply the flow solution rate (gpm) determined in Step 5 by the % of water in the foam solution. Example: If using 3% foam concentrate, the % of water would be 97%.

7. Determine the Discharge Time

Per NFPA 16, 10 minutes of discharge is required.

8. Calculate the Quantity of Foam Concentrate Required

Application Flow Rate (Step No. 2) x % Injection x Discharge Time.

648 gpm (2,453 lpm) (from Step No. 2) x 0.03 x 10 minutes = 194.4 gallons (736 l) of foam concentrate required at minimum application flow rate.

9. Determine the Size and Type of Proportioning Equipment Required

Based on the flow rate and pressure requirements, select the correct size proportioner and bladder tank required.

Monitor Protection

Loading rack requiring monitor protection should be designed to protect the entire surface area of the hazard and can be used to protect the canopy, pumps, meters of other equipment used for the operation of the loading rack.

It is recommended that a minimum of two monitors be used to protect the hazard area. The location of each monitor is determined by several factors: direction of prevailing wind, traffic pattern, any obstructions to block discharge, and range of the selected monitors and nozzles.

NFPA 11 requires a minimum from rate of 0.10 gpm/sq ft* (4.1 lpm/sq m) and a minimum discharge time of 15 minutes when using AFFF, AR-AFFF foam concentrate. These requirements are based on hydrocarbon fuels.

**If a fuel depth of more than 1 in (2.5 cm) can accumulate within the protected area, the application rate shall be increased to 0.16 gpm/sq ft (6.5 lpm/sq m).*

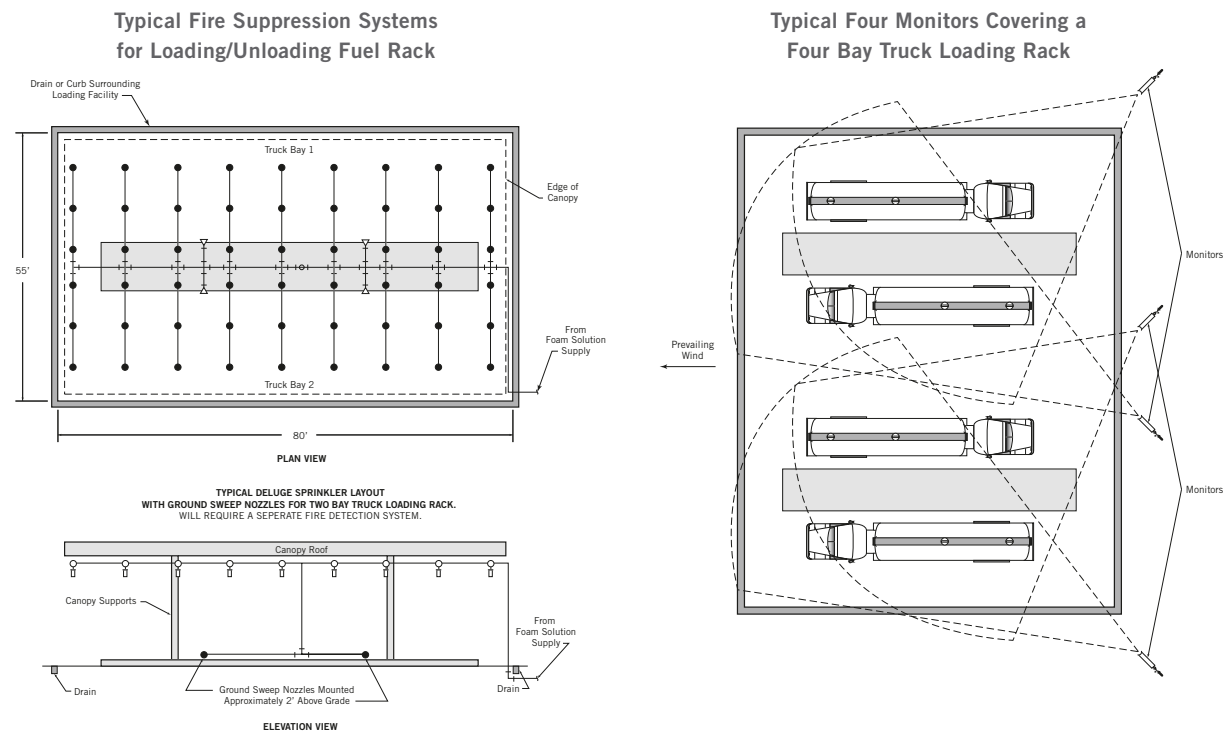



SECTION 6.7
APPLICATIONS
Storage Tank Protection

Section 6.7 – Storage Tank Protection (NFPA 11)

NFPA 11 has established guidelines for the protection of these type hazards. Systems normally are one of two types:

A fixed foam system which is a complete installation consisting of a proportioning system, discharge devices mounted on the tank(s) being protected and all piping between the proportioning equipment and the hazard. All components of the system are permanently installed.



The other type system is a semi-fixed installation. In this type, discharge devices are permanently installed on the tank(s) being protected and piped to a termination point a safe distance from the hazard. The proportioning equipment is transported to the site after a fire has started and connected to the piping system to discharge the foam through the permanently installed discharge device(s).

Types Of Tanks

Fixed (Cone) Roof Tank – Fixed roof tanks are defined as a vertical cylindrical tank with fixed roofs as a conical section and comply with the requirements of NFPA 30. These tanks are designed with a weak seam at the junction of the vertical side and the roof. In the event of an explosion, this seam separates, allowing the roof to blow off, thereby leaving the vertical wall intact to retain the contents of the tank. This type of fire involves the entire exposed surface area of the tank.



Open Top Floating Roof Tank – Open top roof tanks are defined as vertical cylindrical tanks without fixed roofs that have a double deck or pontoon type floating roof and comply with the requirements of NFPA 30. The seal can be a mechanical shoe seal or tube seal. The tube seal can have a metal weather shield. Secondary seals of combustible or non-combustible materials may be installed. Tanks with the following types of roofs do not fall under the design standards for protection of open top floating roof tanks;



- Roofs made of floating diaphragms
- Roofs made from plastic blankets
- Roofs made from plastic or other flotation material, even if encapsulated in metal or fiberglass
- Roofs that rely on flotation device enclosures that can be easily submerged if damaged
- Pan roofs

Although these types of tanks can experience a full surface fire in the event that the roof sinks, experience shows that the most common type of fire in these tanks is a seal fire. The authority having jurisdiction will normally determine the protection required, however, the typical protection is for the seal area only.

SECTION 6.7 – APPLICATIONS

Covered (Internal) Floating Roof Tank – Covered (internal) floating roof tanks are a combination of both the cone roof and the open top-floating roof tanks. The tank has a cone roof but with the addition of an internal floating roof or pan that floats directly on the fuel surface. The open vents in the tank sidewalls, just beneath the roof joints, can identify this type of tank. If the internal floating roof is other than a steel double deck or pontoon type, the fire protection system should be designed for full surface fires (similar to cone roof tanks). For the double deck or pontoon internal roofs of steel construction, a design for the sealed area protection may be permitted (same as open floating roof tanks).



Fuels

Identify the Flammable Liquid – There are two basic classifications of flammable and combustible liquids;

- Hydrocarbons (non-water miscible)
- Polar Solvent (water miscible)

Hydrocarbons include non water-soluble petroleum liquids such as crude oil, gasoline, jet fuels, fuel oil, etc. Polar solvents include water soluble liquids such as alcohols, ketones, esters, etc.

Flammable And Combustible Liquids Per NFPA 30

Flammable Liquid means a liquid having a flash point below 100°F and having a vapor pressure not exceeding 40 psi at 100°F shall be known as a Class I liquid. Class I liquids shall be subdivided as follows:

- Class IA includes those having flash points below 73°F (23°C) and having a boiling point below 100°F (38°C)
- Class IB includes those having flash points below 73°F (23°C) and having a boiling point above 100°F (38°C)
- Class IC includes those having flash points at or above 73°F (23°C) and below 100°F (38°C)

Combustible Liquid means liquid having a flash point at or above 100°F (38°C). Combustible liquids shall be subdivided as follows:

- Class II includes liquids with flash points at or above 100°F (38°C) and below 140°F (60°C)
- Class IIIA includes liquids with flash points at or above 140°F (60°C) and below 200°F (93°C)
- Class IIIB includes liquids with flash points at or above 200°F (93°C)

Discharge Outlets

UL has established two different types of foam discharge outlets:

Type II Discharge Outlet – A fixed device that delivers foam onto the burning liquid and partially submerges the foam and produces restricted agitation of the fuel surface. Examples of this type device are Foam Chambers and Foam Makers.

Type III Discharge Outlet – A fixed or portable device that delivers foam in a manner that causes the foam to fall directly onto the surface of the burning liquid in such a way that causes general agitation. Examples of this type of device are Hose Stream Nozzles and Monitors.

Sub-Surface Injection

The sub-surface method of fire protection produces foam with a High Back Pressure Foam Maker located outside the storage tank. This system delivers the expanded foam mass through piping into the base of the tank. The pipe may be an existing product line or can be a dedicated fire protection foam line. The expanded foam entering the tank through a discharge outlet is injected into the flammable liquid. The discharge outlet must be a minimum of 1 ft (0.3 m) above any water that may be present at the base of the tank. The foam will be destroyed if injected into the water layer. When injected into the fuel, the foam will rise through the fuel and form a vapor tight foam blanket on the fuel surface.

High Back Pressure Foam Maker (HBPFM)

The HBPFM device is mounted in the foam line used to aspirate the foam solution before it is discharged into the storage tank base. It will typically give an expansion ratio of between 2:1 and 4:1. The device is capable of discharging against considerable backpressure, which can be as high as 40% of the operating pressure. The backpressure is an accumulation of head pressure in the fuel inside the storage tank and any friction loss between the foam maker and the tank. A minimum of 100 psi (6.9 bar) inlet pressure into the HBPFM is normally required to ensure correct operation. The foam velocity through the piping to the tank from the HBPFM is very critical. With flammable liquids, the foam velocity entering the tank should not exceed 10 ft (3.1 m) per second, and with combustible liquids, the foam velocity should not exceed 20 ft (6.1 m) per second.

Protection Of Storage Tanks

Fixed (Cone) Roof Tanks Protection

In accordance with NFPA 11, there are three accepted methods of the protection of fixed (cone) roof tanks:

- Surface (Foam Chamber) Method
- Subsurface Injection Method
- Portable Foam Nozzle and Monitor Method

Surface (Foam Chamber) Method

Foam chambers are considered Type II application devices which allow application of expanded foam onto the surface of the fuel with a minimal submergence of the foam and agitation of the fuel surface. The foam chamber is normally mounted on the vertical surface of the storage tank, approx. 8 in to 12 in (20 cm to 30.5 cm) below the roof line. Foam chambers can be used to protect storage tanks containing both hydrocarbon and polar solvent products.

When multiple foam chambers are required, they should be equally spaced on the vertical tank surface and should have the approximate flow rates. The foam solution piping should be installed in accordance with the requirements of NFPA 11 and any other applicable standards. Each foam chamber should be piped separately and contain a shut off valve located outside the diked area.

SECTION 6.7 – APPLICATIONS

Chart “A” - Number of Foam Chambers Required Based on Tank Size

Tank Diameter	Minimum Number of Foam Chambers Required
Up to 80 ft (24.4 m)	1
Over 80 ft (24.4 m) to 120 ft (36.6 m)	2
Over 120 ft (36.6 m) to 140 ft (42.7 m)	3
Over 140 ft (42.7 m) to 160 ft (48.8 m)	4
Over 160 ft (48.8 m) to 180 ft (54.9 m)	5
Over 180 ft (54.9 m) to 200 ft (60.9 m)	6

For tanks over 200 ft (60.9 m) in diameter, one additional outlet foam chamber should be installed for each additional 5,000 sq ft (464.5 sq m) of surface area.

Chart “B” - Application Flow Rate and Discharge Time

Flash Fuel	Minimum* Point	Minimum Flow Rate	Discharge Time
Hydrocarbon	100°F to 140°F (38°C to 60°C)	0.10 gpm/sq ft (4.1 lpm/sq m)	30 minutes
Hydrocarbon	Below 100°F (38°C)	0.10 gpm/sq ft (4.1 lpm/sq m)	55 minutes
Crude Oil	Not Applicable	0.10 gpm/sq ft (4.1 lpm/sq m)	55 minutes
Polar Solvents	Not Applicable	See Solberg	55 minutes

Most hydrocarbon fuels meet the minimum application flow rate of 0.10 gpm/sq. ft. (4.1 lpm/sq. m). There are some hydrocarbons that require higher application flow rates. For polar solvents, NFPA does not establish a minimum flow rate. Although some polar solvents have a minimum flow rate of 0.10 gpm/sq ft (4.1 lpm/sq m), the minimum rate can vary for polar solvents. Consult Solberg for recommendations.

Supplemental Protection

In addition to the primary protection, supplemental hose streams are required for the protection of fixed roof tanks. They are intended for the protection of small spill fires. The minimum quantity of 50 gpm (189 lpm) hose streams required is shown in the following Chart “C”. The number required is based on the size of the largest tank protected by the fire protection system. The proportioning equipment must be capable of flowing the required hoses simultaneously with the main protection system, as well as being able to operate the supplemental hoses without operating the tank systems.

Chart “C” - Supplemental Hose Streams Required

Diameter of Tank	Number of Hose Streams
Up to 65 ft (19.8 m)	1
65 ft to 120 ft (19.8 m to 36.6 m)	2
Over 120 ft (36.6 m)	3

Chart “D” - Operating Time for Supplemental Hose Streams

Diameter of Tank	Minimum Operating Time
Up to 35 ft (10.7 m)	10 minutes
35 ft. to 95 ft (10.7 m to 28.9 m)	20 minutes
Over 95 ft (28.9 m)	30 minutes

System Design

- 1 Determine the fuel in the storage tank
- 2 Determine the type of foam concentrate
- 3 Determine the application flow rate required
- 4 Determine the surface area to be protected
- 5 Determine the amount of foam solution required
- 6 Determine the quantity and size of the foam chambers required
- 7 Determine the required discharge time
- 8 Determine the number of supplementary hose streams required
- 9 Determine the total quantity of foam concentrate required
- 10 Select the proper proportioning equipment

Design Example

Tank Type: Cone Roof
Tank Diameter: 120 ft. (36.6 m)
Fuel: Crude Oil
Available Water: 1,400 gpm (5,300 lpm) at 110 psi (7.6 bar)

1. Determine the Fuel In the Storage Tank

The fuel is crude oil

2. Determine the Type of Foam Concentrate

3% AFFF has been chosen

3. Determine the Application Flow Rate Required

Based on the above flow rate Chart “B”, the required application flow rate for crude oil is 0.10 gpm/sq ft (4.1 lpm/sq m).

4. Determine the Surface Area To Be Protected

The tank diameter is 120 ft (36.6 sq m) which = 11,310 sq ft (1,051 sq m) (Radius² x PI) = 60 ft (18.3 m) x 60 ft (18.3 m) x 3.1416 = 11,310 sq ft (1,051 sq m).

5. Determine the Amount of Foam Solution Required

11,310 sq ft (1,051 sq m) of surface area x 0.10 gpm/sq. ft. (4.1 lpm/sq. m) = 1,131 gallons (4,281 l) of foam solution required.

SECTION 6.7 – APPLICATIONS

6. Determine the Quantity and Size of the Foam Chambers Required

Based on the Chart A, a 120 ft (36.6 m) diameter tank requires 2 foam chambers. The total foam solution required for this tank is 1,131 gallons (4281 l). To determine the size of the foam chambers required, divide the gallons of foam solution by the number of foam chambers required. 1,131 gallons (4281 l) divided by 2 = 566 gpm (2140 lpm) per foam chamber. Select the required foam chamber that will provide the necessary flow at the available water pressure.

7. Determine the Required Discharge Time

Based on the Chart B, crude oil requires a discharge time of 55 minutes.

8. Determine the Number of Supplementary Hose Streams Required

Based on the supplementary hose stream Chart C, a 120 ft (36.6 m) diameter tank requires 2 hose streams, each flowing at 50 gpm (189 lpm). The hose stream must operate for a minimum of 30 minutes.

9. Determine the Total Quantity of Foam Concentrate Required

The total quantity of foam concentrate required must include the quantity required for the foam chambers and the hose streams.

Solution rate for tank x % of injection x time = foam concentrate required for storage tank.

Solution rate for Hose Streams x % of injection x time = foam concentrate required for hoses.

Tank- 1,131 gpm (4281 l) x 0.03 x 55 minutes = 1,866 gallons (7064 l).

Hose Streams – 100 gpm (378 lpm) x 0.03 x 30 minutes = 90 gallons (341 l).

1,866 gallons (7064 l) for tank
+ 90 gallons (341 l) for two hose streams
<hr/>
1,956 total gallons (7404 l) of foam concentrate required

10. Select the Proper Proportioning Equipment

The proportioning equipment must be sized for operation to the largest tank in the system, plus the simultaneous operation of the supplementary hose streams, but should be capable of operating the hose streams without discharging the tank system. The proportioning equipment must have sufficient pressure to operate against the highest expected residual water pressure available.

Subsurface Injection Method

Subsurface foam injection systems can be utilized for the protection of vertical fixed roof tanks containing hydrocarbons. Subsurface injection is not recommended for use on Class 1A liquids or for tanks containing polar solvents. It is also not recommended for use on tanks with pans or floating roofs since the roof can block the flow of the foam if floor sinks. Subsurface foam systems are also not recommended for use with hydrocarbon fuels having viscosities above 2,000 SSU at 60°F (16°C). See NFPA 11.

Foam Discharge Outlets

The number of discharge outlets required is determined by the tank diameter. Where two or more outlets are required, they must be equally spaced around the tank circumference. Each discharge outlet must be designed to discharge the foam at approx. the same flow rate. Discharge outlets can be the open end of the foam discharge line. They must be sized to limit the velocity of the expanded foam at the point of discharge. The maximum velocity must not exceed 10 ft/second (3 m/second) for Class IB fuels and crude oil and 20 ft/second (6.1 m/second) for all others. The height of the discharge outlets must be a minimum of 1 ft (0.3 m) above the highest expected water level of the tank.

Chart “E” - Number of Fixed Foam Outlets Required

Tank Diameter	Minimum Number of Discharge Outlets Flash Point Less Than 100°F (38°C)	Flash Point 100°F (38°C) or Less
Up to 80 ft (24.4 m)	1	1
Over 80 ft to 120 ft (24.4 to 36.6 m)	2	1
Over 120 ft to 140 ft (36.6 to 42.7 m)	3	2
Over 140 ft to 160 ft (42.7 to 48.8 m)	4	2
Over 160 ft to 180 ft (48.8 to 54.9 m)	5	2
Over 180 ft to 200 ft (54.9 to 60.9 m)	6	3
Over 200 ft (60.9 m)	6 (See Note 1)	3 (See Note 2)

Note 1: Add one outlet for each additional 5,000 sq ft (464.5 sq m)

Note 2: Add one outlet for each additional 7,500 sq ft (696.8 sq m)

Chart “F” - Minimum Discharge Time and Application Flow Rate W/AFFF

Fuel	Flash Point	Min. Flow Rate	Min. Discharge Time
Hydrocarbon	100°F to 140°F (38°C to 60°C)	0.10 gpm/sq ft (4.1 lpm/sq m)	30 minutes
Hydrocarbon	Below 100°F (38°C) or liquids heated above flash point	0.10 gpm/sq ft (4.1 lpm/sq m)	55 minutes
Crude Oil	Not Applicable	0.10 gpm/sq ft (4.1 lpm/sq m)	55 minutes

System Design

The system design should be based on the largest single hazard when more than one tank is protected by the same system. It is not required to total all the individual requirements. NFPA standards require that the system be designed for the protection of the largest single hazard.

- 1 Determine the fuel in the storage tank
- 2 Determine the type of foam concentrate
- 3 Determine the application flow rate
- 4 Determine the surface area to be protected
- 5 Determine the amount of foam solution required
- 6 Determine the quantity and size of the foam discharge outlets
- 7 Determine the back pressure down stream of the foam maker

SECTION 6.7 – APPLICATIONS

- 8 Determine the required discharge time
- 9 Determine the number of supplementary hose streams required
- 10 Determine the total quantity of foam concentrate required
- 11 Select the proper proportioning equipment

Design Example

Tank Type:	Cone Roof
Tank Diameter:	120 ft (36.6 m)
Tank Height:	40 ft (12.2 m)
Fuel:	Crude Oil
Available Water:	1,400 gpm at 110 psi (5300 lpm at 7.6 bar)

1. Determine the Fuel In the Storage Tank

The storage tank contains crude oil.

2. Determine the Type of Foam Concentrate

3% AFFF has been chosen.

3. Determine the Application Flow Rate

Based on the flow rate Chart “F”, the required application flow rate for crude oil is 0.10 gpm/sq ft (4.1 lpm/sq m).

4. Determine the Surface Area To Be Protected

The tank diameter is 120 ft (36.6 m) which = 11,310 sq ft (1051 sq m)...(Radius² x PI) = 60 ft x 60 ft x 3.1416 = 11,310 sq ft (18.3 m x 18.3 m x PI = 1,051 sq m).

5. Determine the Amount of Foam Solution Required

11,310 sq ft (1051 sq m) of surface area x 0.10 gpm/sq ft (4.1 lpm/sq m) = 1,131 gallons (4,281 l) of foam solution required.

6. Determine the Quantity and Size of the Foam Discharge Outlets

Based on the discharge outlet Chart “E”, the 120 ft (36.6 m) diameter tank requires 2 foam discharge outlets.

The total solution required for this tank is 1,131 gpm (4,281 l). To determine the solution flow per each discharge outlet, divide the total flow by the number of discharge outlets. 1,131 gpm (4,281 l) solution flow divided by 2 discharge outlets = 566 gpm (2,142 l) per each outlet.

Multiply the solution flow rate per discharge outlet x the expansion to determine the amount of expanded foam solution discharged per outlet.

566 gpm (2,142 l) solution x 4 (expansion) = 2,264 gpm (8,570 l) expanded foam per discharge.

Determine maximum velocity allowed.

Based on the fuel classification, the maximum velocity for crude oil is 10 ft/sec (3.1 m/sec).

Determine pipe size that will not exceed this velocity.

Velocity Formula: $V(\text{ft}/\text{sec.}) = \frac{\text{gpm foam}}{D^2} \times 0.4085$ (D = Pipe diameter in inches)

Based on the above calculation, 8 in. pipe has a velocity of 8.6 ft/sec (2.6 m/sec). This is the smallest pipe size which can be used for each discharge outlet without exceeding the 10 ft/sec (3.1 m/sec) maximum velocity. Therefore, the tank requires two 8 in. discharge outlets.

7. Determine the Back Pressure Down Stream of the Foam Maker

In this example, the foam maker will flow at 1,131 gpm (4,282 lpm). Refer to Solberg Foam Maker data sheet(s) to determine the required inlet pressure. When sizing the piping between the tank and the foam maker, the calculated piping loss plus the head loss at the tank and not exceed the allowable back pressure].

8. Determine the Required Discharge Time

Based on the Min. Discharge time and Application Rate Chart “F”, Crude Oil requires a 55 minute discharge time.

9. Determine the Number of Supplementary Hose Streams Required

Based on the supplementary hose stream Chart C”, a 120 ft (36.6 m) diameter tank requires 2 hose streams each flowing at 50 gpm (189 lpm). They must operate for a minimum of 30 minutes.

10. Determine the Total Quantity of Foam Concentrate Required

Total quantity of foam concentrate required is as follows:

Foam solution rate for tank x % of injection x time = foam concentrate required for tank.

Foam solution rate for hose streams x % of injection x time = foam concentrate required for hose streams.

Tank – 1,131 gpm (4282 lpm) x 0.03 x 55 minutes = 1,866 gallons (7064 l) of foam concentrate.

Hose Streams – 100 gpm (378 l) x 0.03 x 30 minutes = 90 gallons (341 l) of foam concentrate.

1,866 gal	7064 l	
+ 90 gal	+341 l	
1,956 gal	(7404 l)	total quantity of foam concentrate required

11. Select the Proper Proportioning Equipment

The proportioning system must be sized for operation of the largest tank in the system, plus simultaneous operation of the supplementary hose streams. The system should be capable of operating the hose streams without discharging the tank system. The proportioning system must have sufficient pressure to operate against the highest expected residual water pressure.

Handlines And Foam Monitors Only

Where it is acceptable by the authority having jurisdiction (AHJ), portable foam nozzles may be used for protection of fixed roof tanks containing hydrocarbons. The tanks may not be more than 30 ft (9.1 m) in diameter and can not be more than 20 ft (6.1 m) in height.

Foam monitors may be used for the protection of fixed roof tanks up to 60 ft (18.3 m) in diameter.

Neither handlines nor monitors are considered acceptable for protecting tanks containing polar solvents regardless of the tank size.

The chart below states the minimum discharge time and application flow rate when protecting fixed roof tanks containing hydrocarbons with only handlines or monitors.

SECTION 6.7 – APPLICATIONS

Chart “G” – Minimum Discharge Time and Application Rate

Fuel	Flash Point	Min. Application Rate	Min. Discharge Time
Hydrocarbon	100°F to 140°F (38°C to 60°C)	0.16 gpm/sq ft (6.5 lpm/sq m)	50 minutes
Hydrocarbon	Below 100°F (38°C) or Liquids heated above flash point	0.16 gpm/sq ft (6.5 lpm/sq m)	65 minutes
Crude Oil	Not Applicable	0.16 gpm/sq ft (6.5 lpm/sq m)	65 minutes

Open Top Floating Roof Tank Protection

Two types of protection are available for the protection of open top floating roof tanks. The first type of protection utilizes a permanent fixed piping system to discharge the foam concentrate in the area above the mechanical seal, weather shield or secondary seal. The second type of protection utilizes a permanent fixed piping system to discharge the foam concentrate below the mechanical seal, directly onto the flammable liquid surface, behind the weather shield, directly onto the tube seal or beneath the secondary seal, directly on the primary seal.

There are two general types of seals according to NFPA 11: Pantograph (Mechanical Shoe) Seal and Tube Seals.

A pantograph type floating roof typically contains a fabric seal that is anchored to the roof and rides on the inside of the tank wall. A pantograph or mechanical shoe system is attached below the fabric seal to keep the roof aligned within the tank. See figure below.

A tube seal is typically constructed of a urethane foam contained within a durable envelope. The seal is connected to the edge of the floating roof around the entire circumference of the tank. A weather shield or secondary seal is installed above the tube seal. See figure below.

Above the seal area – When this type of protection is utilized, top of seal protection utilizes either floating roof foam makers or foam chambers connected to the tank wall above the seal. When this type of protection is used, a foam dam is required to contain the foam in the seal area. The foam dam is typically 12 to 24 in (31 to 61 cm) high.

Below the seal area – When this type of protection is utilized, below seal protection utilizes a floating roof foam maker mounted on the floating roof. Piping is run from the foam maker and is penetrated through the fabric seal, secondary seal or the weather seal. A foam dam may be required depending on the type of seals present. Because the foam maker is mounted on the floating roof, special distribution piping may be required. Contact Solberg for system requirements.

Number of Discharge Devices Required

The number of foam discharge devices required is based on the circumference of the tank and the height of the foam dam. If a foam dam with a minimum height of 24 in. (61 cm) is installed, the maximum spacing between the discharge devices increases. See the Chart “H” below for maximum spacing for each type seal.

Chart “H” – Maximum Dam Spacing and Minimum Discharge Time and Application Rates

Seal Type	Application Rate	Min. Discharge Time	Maximum Spacing of Seal Discharge Outlets	
			12 in (31 cm) Dam	24 in Dam

Mechanical shoe	0.3 gpm/sq ft (12.2 lpm/sq m)	20 minutes	40 ft (12.2 m)	80 ft (24.4 m)
Tube Seal w/metal weather seal	0.3 gpm/sq ft (12.2 lpm/sq m)	20 minutes	40 ft (12.2 m)	80 ft (24.4 m)
Full or partly combustible secondary seal	0.3 gpm/sq ft (12.2 lpm/sq m)	20 minutes	40 ft (12.2 m)	80 ft (24.4 m)
All metal secondary seal	0.3 gpm/sq ft (12.2 lpm/sq m)	20 minutes	40 ft (12.2 m)	80 ft (24.4 m)

System Design – Above the Seal Protection

The system design should be based on the largest single hazard when more than one tank is protected by the same system. It is not required to total all the individual requirements. NFPA standards require that the system be designed for the protection of the largest single hazard.

1. Determine the type of fuel in the storage tank
2. Determine the type of foam concentrate
3. Determine the application flow rate
4. Determine the annular area to be protected
5. Determine the amount of foam solution required
6. Determine the quantity and size of the foam discharge devices
7. Determine the required discharge time
8. Determine the number of supplementary hose streams required
9. Determine the total of foam concentrate required
10. Select the proper proportioning equipment

Design Example – Above the Seal Protection

Tank Type:	Open Top Floating Roof
Type of Protection:	Above the Seal
Tank Diameter:	110 ft (33.5 m)
Tank Height:	45 ft (13.7 m)
Fuel:	Crude Oil
Height of Foam Dam:	24 in (61 cm)
Width of Annular Area:	14 in (36 cm)
Type of Seal:	Tube Seal With Weather Shield
Available Water:	1,400 gpm @ 110 psi (5300 lpm @ 7.6 bar)

1. Determine the Type of Fuel in the Storage Tank

The type of fuel is crude oil.

2. Determine the Type of Foam Concentrate

SECTION 6.7 – APPLICATIONS

3% AFFF has been chosen.

3. Determine the Application Flow Rate

The application flow rate for crude oil is 0.3 gpm/sq ft (1.1 lpm/sq m).

4. Determine the Annular Area to be Protected

This is determined by taking the diameter of the tank minus the diameter of the foam dam.

Area of 110 ft (33.6 m) diameter tank = $55 \text{ ft} \times 55 \text{ ft} \times 3.1416 \text{ (PI)} = 9,504 \text{ sq ft}$

($16.8 \text{ m} \times 16.8 \text{ m} \times 3.1416 \text{ (PI)} = 886.7 \text{ sq m}$)

Area of 106 ft (32.3 m) diameter foam dam = $53 \text{ ft} \times 53 \text{ ft} \times 3.1416 = 8,825 \text{ sq ft}$

($16.2 \text{ m} \times 16.2 \text{ m} \times 3.1416 \text{ (PI)} = 820 \text{ sq m}$)

Annular Area = $9,504 \text{ sq ft} - 8,825 \text{ sq ft} = 679 \text{ sq ft}$

($886.7 \text{ sq m} - 820 \text{ sq m} = 66.7 \text{ sq m}$)

5. Determine the Amount of Foam Solution Required

This is determined by multiplying the annular ring area by the application flow rate.

$679 \text{ sq ft} (66.7 \text{ sq m}) \times 0.3 \text{ gpm/sq ft} (12.2 \text{ lpm/sq m}) = 204 \text{ gpm} (772 \text{ lpm})$ of solution required.

6. Determine the Quantity and Size of the Foam Discharge Devices

The quantity of discharge devices required is determined by the circumference of the tank and the maximum spacing allowed based on the height of the foam dam. The amount of solution required for each discharge device is derived by dividing the total foam solution flow required by the number of discharge devices.

Based on the Chart "H", the tank can use 80 ft (24.4 m) spacing between each discharge device based on a 24 in (61 cm) high foam dam.

The 110 ft (33.5 m) diameter tank has a circumference of 346 ft (105.5 m).

The number of discharge devices required is determined by dividing the circumference by the maximum spacing allowed for the device.

$346 \text{ ft} (105.5 \text{ m})$ divided by $80 \text{ ft} (24.4 \text{ m}) = 4.3$ or 5 discharge devices required.

To determine the size of the discharge device, divide the total flow rate by the number of devices.

$204 \text{ gpm} (772 \text{ lpm})$ solution flow rate divided by 5 (no. of devices required) = $41 \text{ gpm} (155 \text{ lpm})$ per discharge device.

Select a discharge device that will provide that flow at the available pressure.

7. Determine the Required Discharge Time

Based on the Chart "H", the tube seal with weather shield requires a 20 minute discharge time.

8. Determine the Number of Supplementary Hose Streams Required

Based on the supplementary hose stream Chart "C", the 110 ft (33.6 m) diameter tank requires 2 hose streams each flowing at 50 gpm (189 l). The hose streams have to operate for a minimum of 30 minutes.

9. Determine the total of Foam Concentration Required

Solution rate for tank x % of injection x time = foam concentrate required for tank.

Solution rate for hose streams x % of injection x time = foam concentrate required for hose streams.

Tank - 204 gpm x 0.03 x 20 = 123 gallons (772 lpm x 0.03 x 20 = 464 l)

Hose Streams – 100 gpm x 0.03 x 30 = 90 gallons (479 lpm x 0.03 x 30 = 331 l)

123 gallons (466 l)

+90 gallons (341)

213 total gallons (807 l) of foam concentrate required

10. Select the Proper Proportioning Equipment

The proportioning system must be sized for operation of the largest tank in the system, plus simultaneous operation of the supplementary hose streams. The system should be capable of operating the hose streams without discharging the tank system. The proportioning system must have sufficient pressure to operate against the highest expected residual water pressure.

System Design –Below the Seal Protection

The system design should be based on the largest single hazard when more than one tank is protected by the same system. It is not required to total all the individual requirements. NFPA standards require that the system be designed for the protection of the largest single hazard.

Chart “I” – Maximum Outlet Spacing and Minimum Discharge Time and Application Rates

Seal Type	Application Rate	Minimum Discharge Time	Maximum Spacing Between Discharge Outlets
Mechanical Shoe	0.5 gpm/sq ft (20.4 lpm/sq m)	10 minutes	130 ft (40 m) (dam not required)
Tube Seal w/more than 6 in (15 cm) between top of tube and top of pontoon	0.5 gpm/sq ft (20.4 lpm/sq m)	10 minutes	60 ft (18 m) (dam not required)
Tube seal w/less than 6 in (15 cm) between top of tube and top of pontoon	0.5 gpm/sq ft (20.4 lpm/sq m)	10 minutes	60 ft (18 m) (dam not required)
Tube seal w/foam discharge (20.4 lpm/sq m) below metal secondary seal*	0.5 gpm/sq ft	10 minutes	60 ft (18 m) (dam not required)

*Secondary seal acts as a foam dam

1. Determine the type of fuel in the storage tank
2. Determine the type of foam concentrate
3. Determine the application flow rate
4. Determine the annular area to be protected

SECTION 6.7 – APPLICATIONS

5. Determine the amount of foam solution required
6. Determine the quantity and size of the foam discharge devices
7. Determine the required discharge time
8. Determine the number of supplementary hose streams required
9. Determine the total of foam concentrate required
10. Select the proper proportioning equipment

Design Example – Below the Seal Protection

Tank Type:	Open Top Floating Roof
Type of Protection:	Below the Seal
Tank Diameter:	110 ft (33.5 m)
Tank Height:	45 ft (13.7 m)
Fuel:	Crude Oil
Height of Foam Dam:	Not Applicable
Width of Annular Area:	12 in (31 cm)
Type of Seal:	Shoe Seal
Available Water:	1,400 gpm @ 110 psi (5300 lpm @ 7.6 bar)

1. Determine the Type of Fuel in the Storage Tank

The type of fuel is crude oil.

2. Determine the Type of Foam Concentrate

3% AFFF has been chosen.

3. Determine the Application Flow Rate

The application flow rate for crude oil is 0.5 gpm/sq ft (20.4 lpm/sq m).

4. Determine the Annular Area to be Protected

This is determined by taking the diameter of the tank minus the diameter of the foam dam.

Area of 110 ft (33.5 m) diameter tank = 55 ft x 55 ft. x 3.1416 = 9,504 sq ft (16.8 m x 16.8 m x 3.1416 (PI) = 883 sq m).

Area of 108 ft (32.9 m) diameter foam dam = 54 ft x 54 ft x 3.1416 = 9,161 sq ft (16.5 m x 16.5 m x 3.1416 (PI) = 851 sq m).

Annular Area = 9,504 sq ft – 9,161 sq ft = 343 sq ft (883 sq m – 851 sq m = 31.9 sq m).

5. Determine the Amount of Foam Solution Required

This is determined by multiplying the annular ring area by the application flow rate.

343 sq ft (31.9 sq m) x 0.5 gpm/sq ft (20.4 lpm/sq m) = 172 gpm (651 lpm) of solution required

6. Determine the Quantity and Size of the Foam Discharge Devices

The quantity of discharge devices required is determined by the circumference of the tank and the maximum spacing allowed for each discharge device. The amount of solution required for each discharge device is derived by dividing the total foam solution flow required by the number of discharge devices.

Based on the Chart “I”, the tank can use 130 ft (39.6 m) spacing between each discharge device based on the shoe type seal.

The 110 ft (33.5 m) diameter tank has a circumference of 346 ft (105.5 m)

The number of discharge devices required is determined by dividing the circumference by the maximum spacing allowed for the device.

346 ft (105.5 m) divided by 130 ft (39.6 m) = 2.7 or 3 discharge devices required

To determine the size of the discharge device, divide the total flow rate by the number of devices.

172 gpm (651 lpm) solution flow rate divided by 3 (no. of devices required) = 58 gpm (220 lpm) per discharge device.

Select a discharge device that will provide that flow at the available pressure

7. Determine the Required Discharge Time

Based on the Chart “I”, the shoe seal requires a 10 minute discharge time

8. Determine the Number of Supplementary Hose Streams Required

Based on the supplementary hose stream Chart “C”, the 110 ft (33.5 m) diameter tank requires 2 hose streams each flowing at 50 gpm (189 lpm). The hose streams have to operate for a minimum of 30 minutes.

9. Determine the total of Foam Concentration Required

Solution rate for tank x % of injection x time = foam concentrate required for tank

Solution rate for hose streams x % of injection x time = foam concentrate required for hose streams

Tank – 172 gpm x 0.03 x 10 = 52 gallons (651 lpm x 0.03 x 10 = 197 l)

Hose Streams – 100 gpm x 0.03 x 30 = 90 gallons (379 lpm x 0.03 x 30 = 341 l)

52 gallons (197 l)

+90 gallons (341)

142 total gallons (538 l) of foam concentrate required

10. Select the Proper Proportioning Equipment

The proportioning system must be sized for operation of the largest tank in the system, plus simultaneous operation of the supplementary hose streams. The system should be capable of operating the hose streams without discharging the tank system. The proportioning system must have sufficient pressure to operate against the highest expected residual water pressure.

Portable Handline Method

The handline method can be used by firefighter to apply foam solution directly on the seal area that is on fire. On the type of fire protection, a hose station, containing two 1½ in valved hose connections to located on the platform at

SECTION 6.7 – APPLICATIONS

the top of the tank stairs. The fire fighter can use the handlines to discharge foam directly onto the fire area. A fixed discharge device should be mounted under the platform to protect the fire fighters. This discharge device should have a minimum flow rate of 50 gpm (189 lpm) and should cover the seal area a minimum of 40 ft (12.2 m) on both sides of the platform. This type of application requires that a foam dam be installed. NFPA does not state the required application rate or the minimum discharge time since this type of protection is a spot application and there is no way to determine how large the fire will be. NFPA limits this type of fire protection to storage tanks not exceeding 250 ft (76 m) in diameter.

Covered (Internal) Floating Roof Tanks

Covered (internal) floating roof tanks have a fixed roof equipped with a ventilation system and will contain a double deck or pontoon type of floating roof. They can also be constructed with a metal floating roof cover supported by a liquid tight metal flotation device. NFPA 30 specifies the construction requirements. Fixed foam fire protection systems are usually not used for this type of hazard. If local authorities or AHJ's require the use of fixed fire protection systems, NFPA has established the following guidelines.

Because of the design, Covered (internal) Floating Roof Tanks can have a complete surface fire as well as a seal fire. The type of protection required is normally based on the construction of the floating roof. Tanks containing the following types of roof construction are considered suitable for seal area protection:

- Steel double deck
- Steel pontoon
- Full liquid surface contact, closed cell honeycomb of metal construction conforming to API 650 (Appendix H, Internal Floating Roof Requirements)

Tanks constructed utilizing the following types of floating roofs do not fall under the design requirements for seal protection of covered (internal) floating roof tanks

- Roofs constructed with floating diaphragms
- Roofs constructed with plastic blankets
- Roofs constructed with plastic or other floatation material, even if encapsulated in metal or fiberglass
- Roofs that rely on floatation device enclosures that can be easily submerged if damaged
- Pan roofs

These type tanks require full surface protection and fall under the requirements for fixed roof tanks.

Foam systems for covered floating roof tanks should be designed to protect the entire fuel surface. If the floating pan is pinned at the top of the tank, foam chambers should be located in a position so that the tank is protected with the pan in the pinned position. Design of the foam system is the same as for fixed (cone) roof tanks, except there is no requirement for separate valved laterals for each discharge device. Subsurface foam injection is not recommended for this type tank.

Supplementary handline protection is required.

Design Example

The fire protection design for Covered (internal) Floating Roof tanks is the same as the design requirements for surface protection of Fixed (Cone) Roof tanks. Refer to DESIGN EXAMPLE for surface protection of Fixed (Cone) Roof tanks.

**TYPICAL ARRANGEMENT FOR SUB-SURFACE SYSTEMS
INTO A CONE ROOF STORAGE TANK**

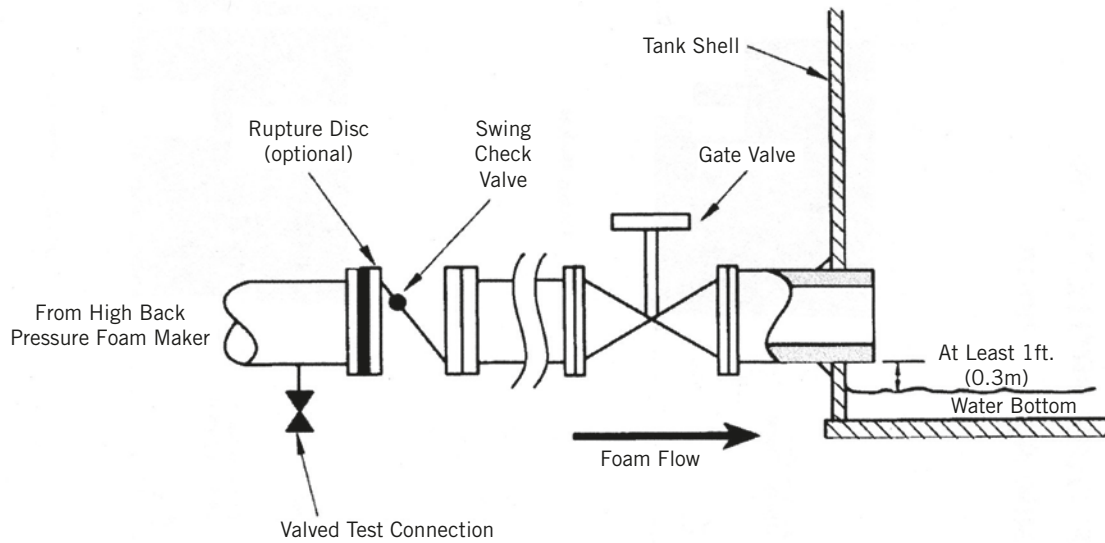

TYPICAL OUTLETS FOR SUB-SURFACE INJECTION INSIDE CONE ROOF STORAGE TANKS

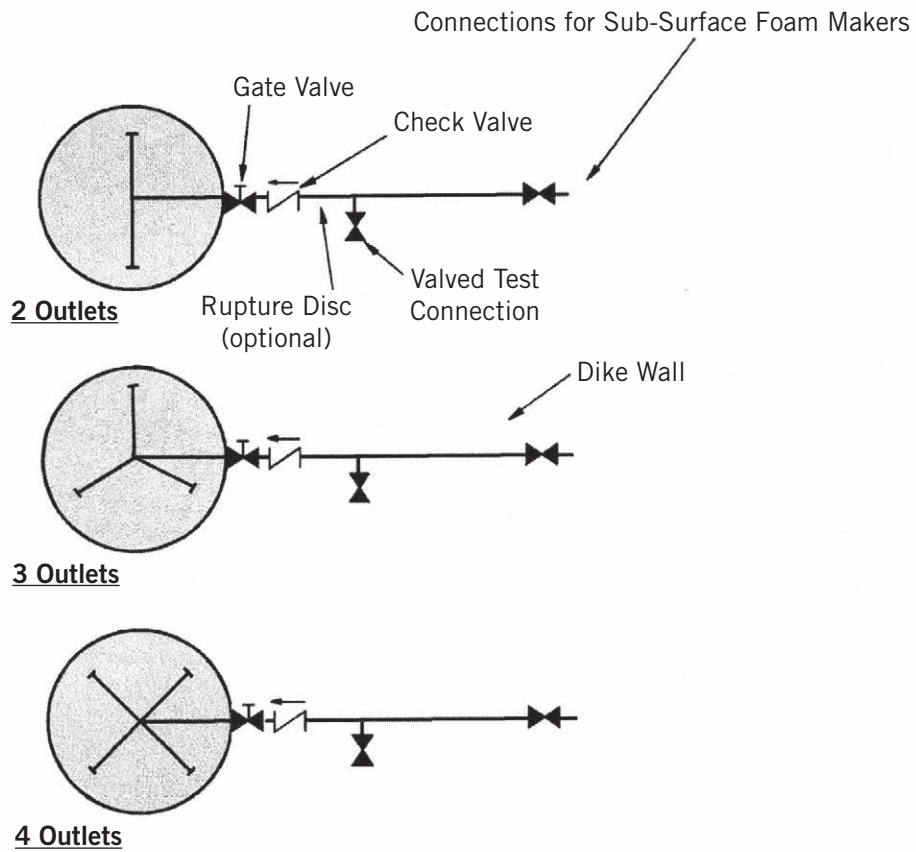

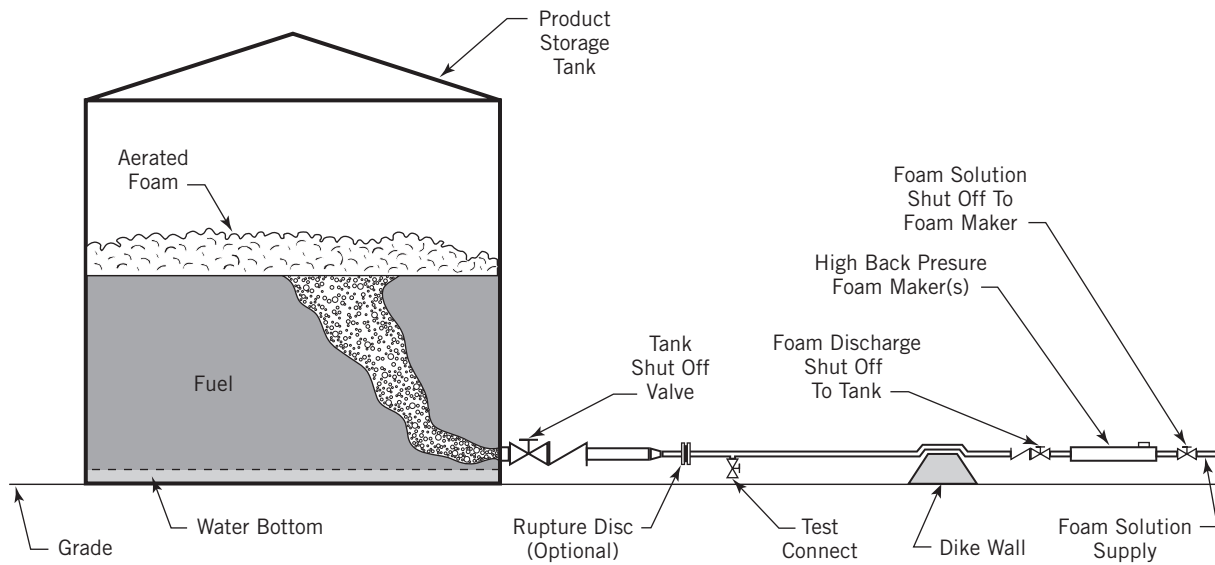

Sub-Surface Injection Application for Fixed Roof Tanks

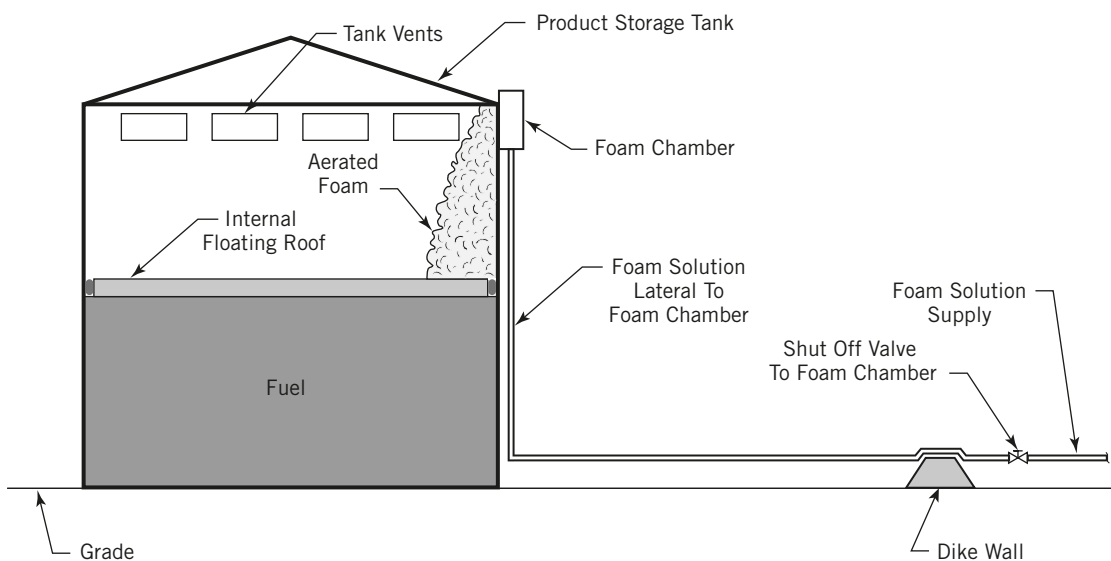

Surface Application Using Foam Chambers for Covered Floating Roof Tanks

SECTION 6.7 – APPLICATIONS

Typical Foam Systems Illustrations for Top-of-Seal Fire Protection. Both fixed foam (wall-mounted) and roof-mounted discharge outlets are shown for illustrative purposes. Although both methods are shown, only one is needed.

Typical Foam Systems Arrangement Illustrations for Below-the-Seal (or Shield) Application.

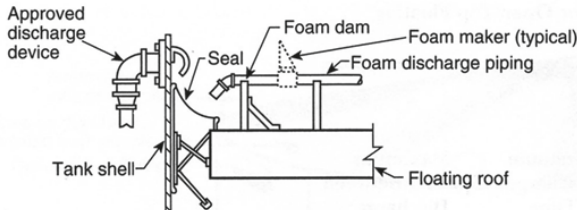

DETAIL A — Top-of-seal application
Foam discharge above mechanical shoe seal

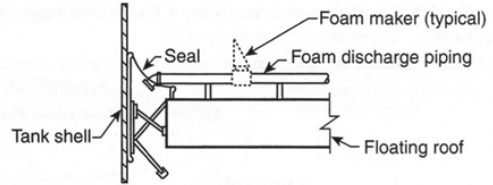

DETAIL A — Below-the-seal application
Foam discharge below mechanical shoe seal — no foam dam

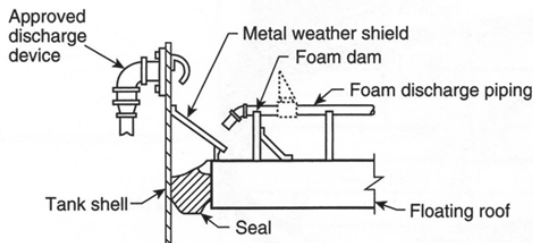

DETAIL B — Top-of-seal application
Foam discharge above metal weather seal

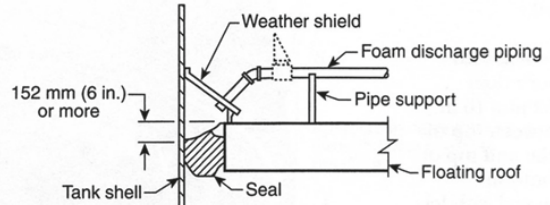

DETAIL B — Below-the-shield application
Foam discharge below metal weather shield
Top of seal 152 mm (6 in.) or more below top of floating roof

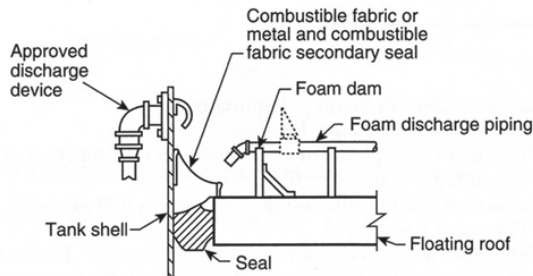

DETAIL C — Top-of-seal application
Foam discharge above secondary combustible fabric seal, or metal with combustible fabric sections

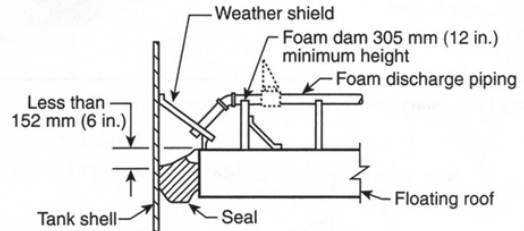

DETAIL C — Below-the-shield application
Foam discharge below metal weather shield
Top of seal less than 152 mm (6 in.) below top of floating roof

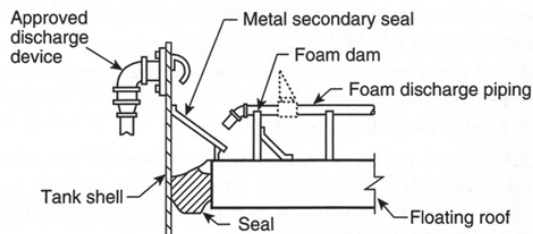

DETAIL D — Top-of-seal application
Foam discharge above metal secondary seal

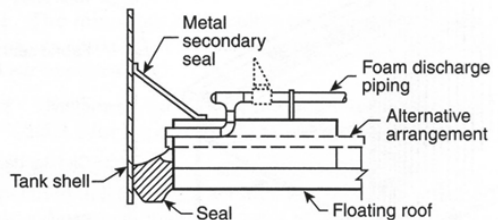

DETAIL D — Below-the-seal application
Foam discharge below metal secondary seal
This foam application method is not acceptable if secondary seal is constructed of any combustible fabric sections. (Refer to application above seal.)

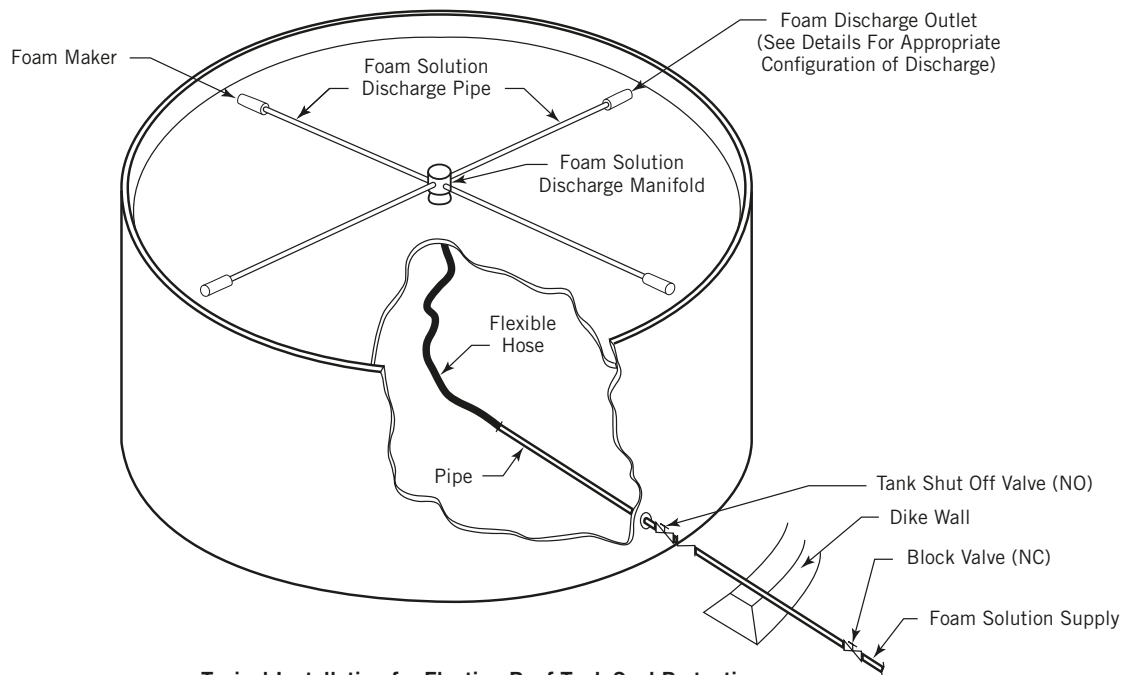

**Typical Installation for Floating Roof Tank Seal Protection
Using Flexible Hose Through Bottom of Roof and Roof Mounted Foam Makers**

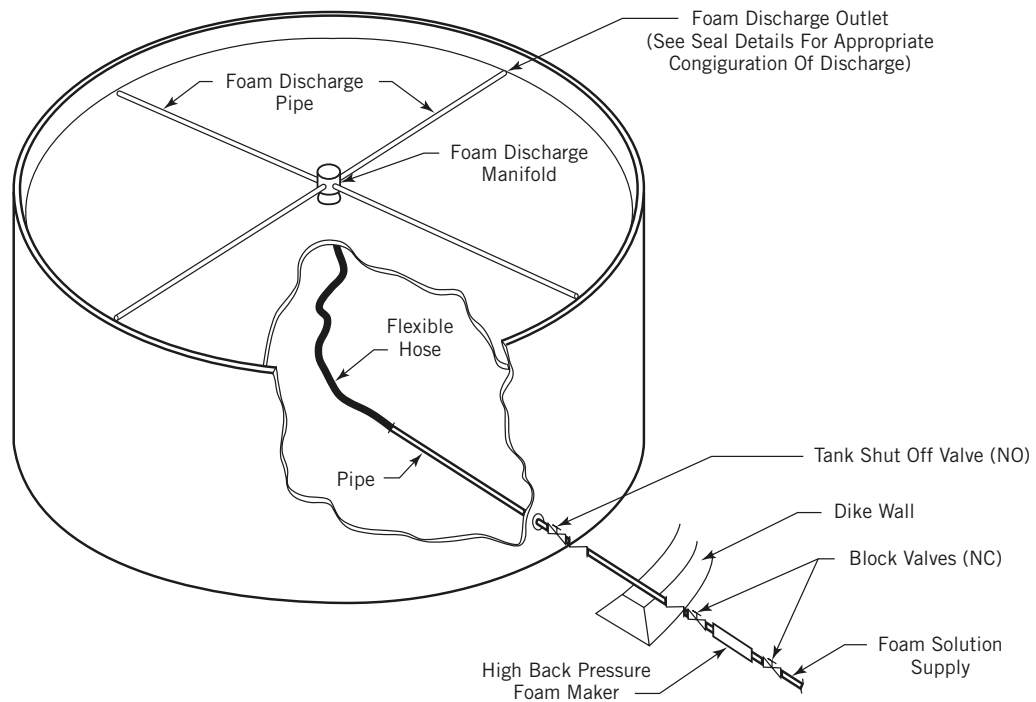

**Typical Installation for Floating Roof Tank Seal Protection
Using Foam Supplied From High Back Pressure Foam Maker
Flexible Hose Through Bottom of Roof and Manifold**

SECTION 6.7 – APPLICATIONS

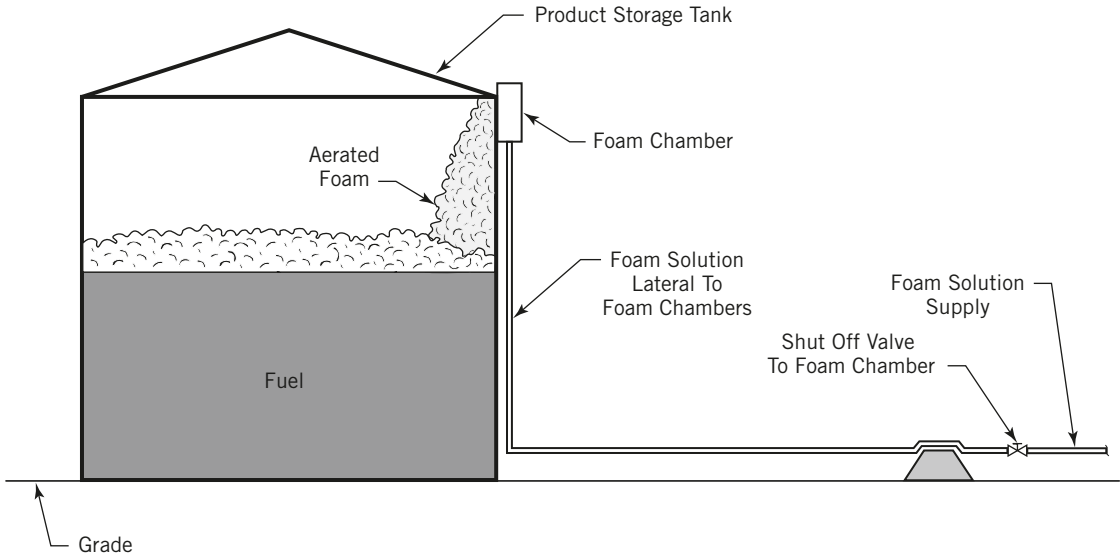

Surface Application Using Foam Chambers for Fixed Roof Tanks

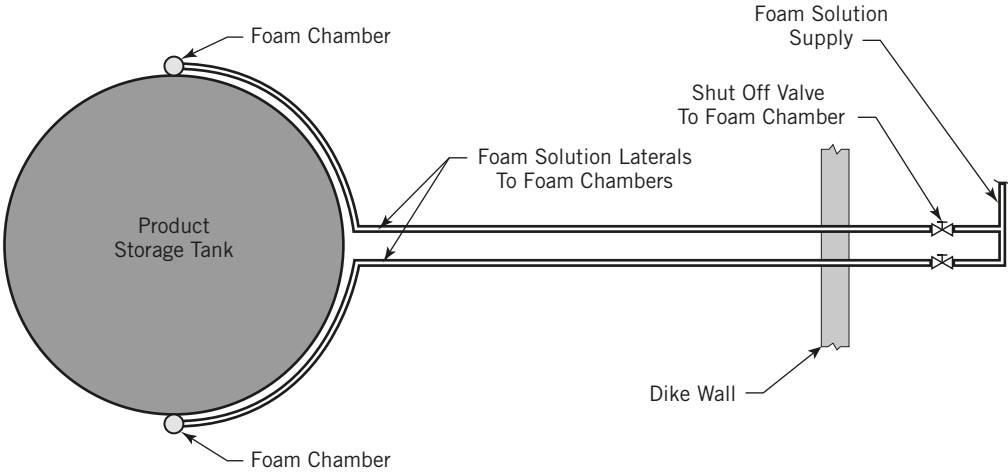

Surface Application Using Multiple Foam Chambers for Fixed Roof Tanks



Storage Tank Protection

SURFACE INJECTION

Determining Inlet Pipe Size

NFPA 11 states that the foam velocity at the point of discharge into the tank shall not exceed 10 ft. per second (3 m/sec) for Class B liquids or 20 ft. per second (6.1 m/sec) for other liquids, unless actual tests prove higher velocities are satisfactory. The inlet pipe for subsurface injection must be of adequate size that the expanded foam flow does not exceed the inlet velocity recommendation. Adequate inlet size can be found by multiplying the flow rate needed for the tank by 4 (maximum expansion expected) to get the expanded foam rate, and then comparing this with the chart below for the approximate pipe size.

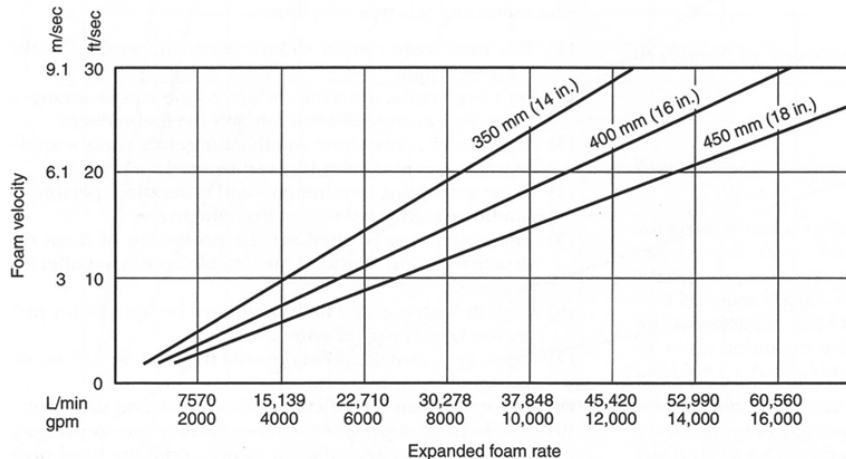
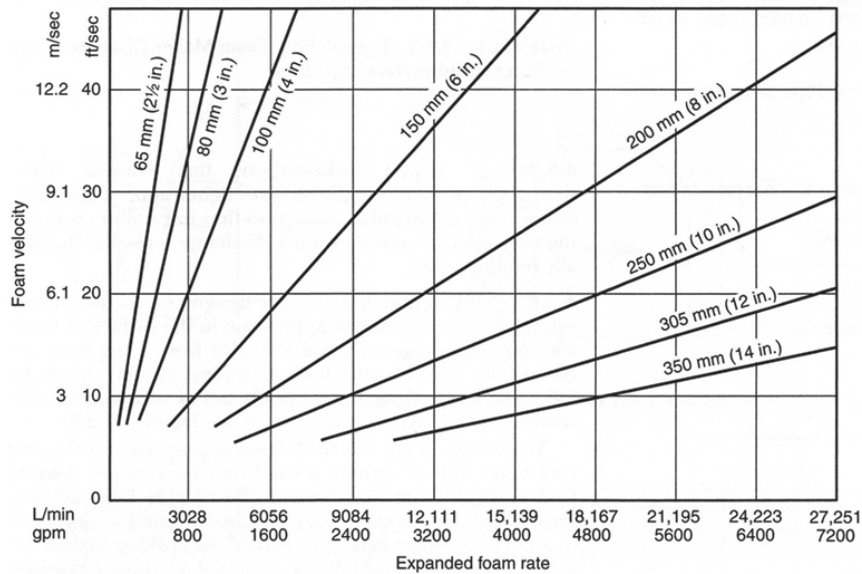

Storage Tank Protection

SURFACE INJECTION

Determining Static Head Pressure

To use the chart below, find the Static Head (maximum height of liquid) at left side of chart. Read across chart to intersection with Specific Gravity curve for fuel in tank. The Static Head Pressure is the measurement at the bottom of the chart directly below the intersection.

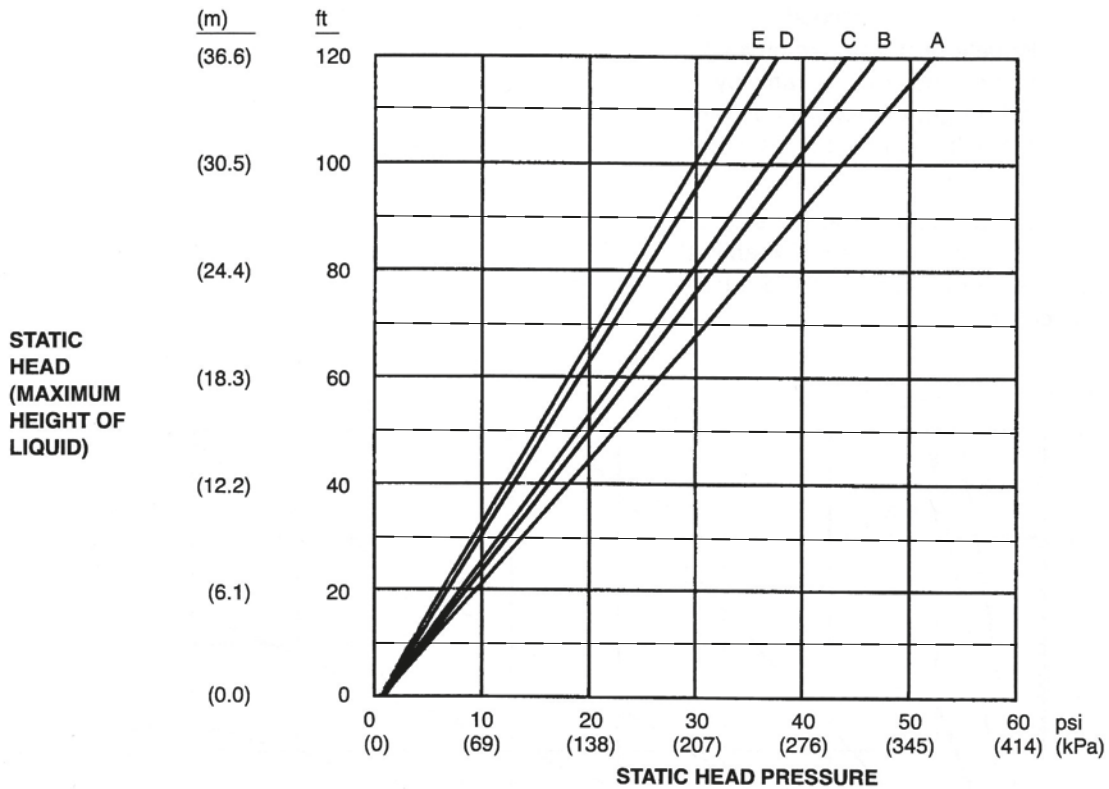

- Specific Gravity
- A = 1.00 (WATER)
 - B = 0.90 (Oils)
 - C = 0.84 (Fuel Oil)
 - D = 0.72 (Gasoline)
 - E = 0.68 (Heptane)

Storage Tank Protection

SUBSURFACE INJECTION

Determining Expanded Foam Friction Losses Vs. Pipe Size

To use the chart below, first determine Maximum Allowable Friction Loss and Expanded Foam Rate using the following formulas:

$$\text{MAXIMUM ALLOWABLE FRICTION LOSS} = \text{MAXIMUM ALLOWABLE BACK-PRESSURE} - \text{STATIC HEAD PRESSURE}$$

$$\text{EXPANDED FOAM RATE} = \text{FOAM SOLUTION DISCHARGE RATE} \times \text{EXPANSION RATIO (94)}$$

Next find the Expanded Foam Rate at the bottom of the chart. Read up the chart until intersecting with minimum size that is under Maximum Allowable Friction Loss.

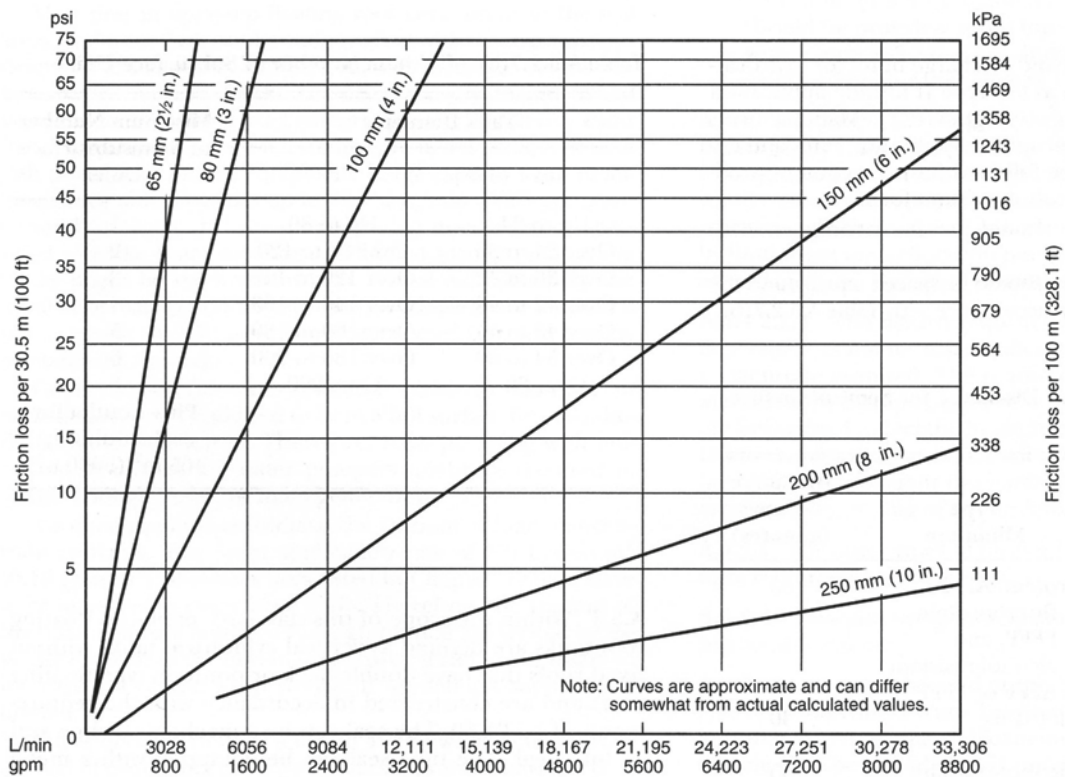

— Standard Schedule 40 Pipe.

Storage Tank Protection

TYPICAL TOP OF SEAL SYSTEM

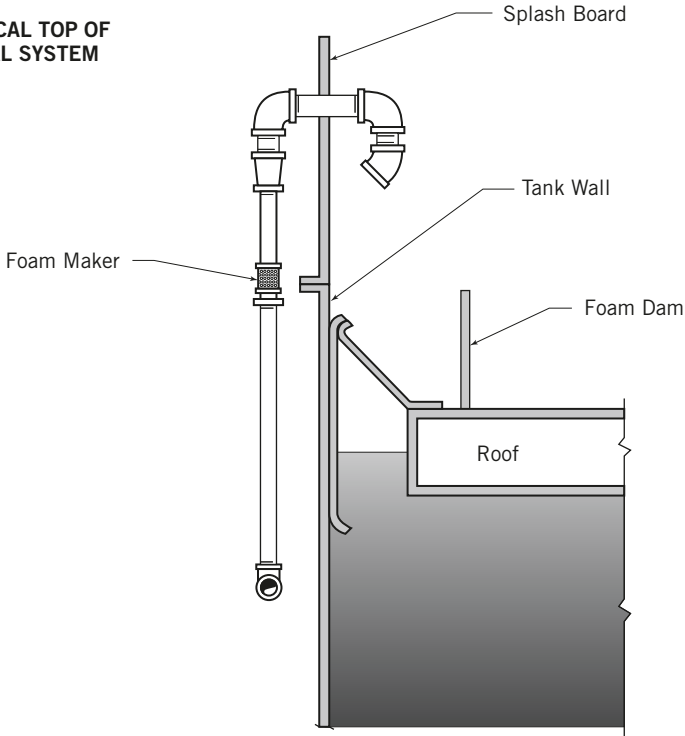

TYPICAL TOP OF SEAL SYSTEM

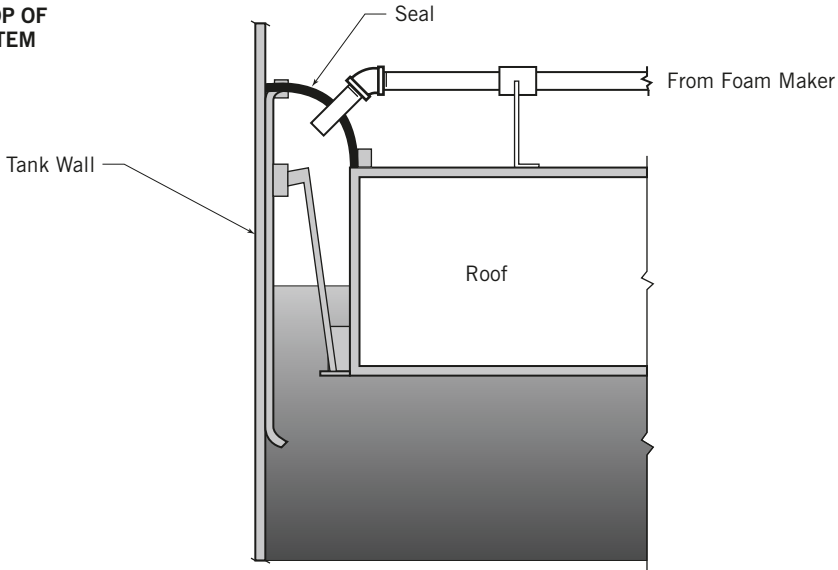

Storage Tank Protection

SURFACE APPLICATION

Calculating Annular Ring Area (Floating Roof Tanks)

For tanks with foam dams, the annular ring is the area between the foam dam and the tank wall. For tanks without foam dams, the annular ring is the area between the tank wall and the inside base of the secondary seal. It is calculated by subtracting the unprotected roof area from the total surface area of the tank as follows:

$$\text{ANNULAR RING AREA} = \text{TOTAL SURFACE AREA} - \text{UNPROTECTED ROOF AREA}$$

$$(\pi r^2) \quad (\pi r^2)$$

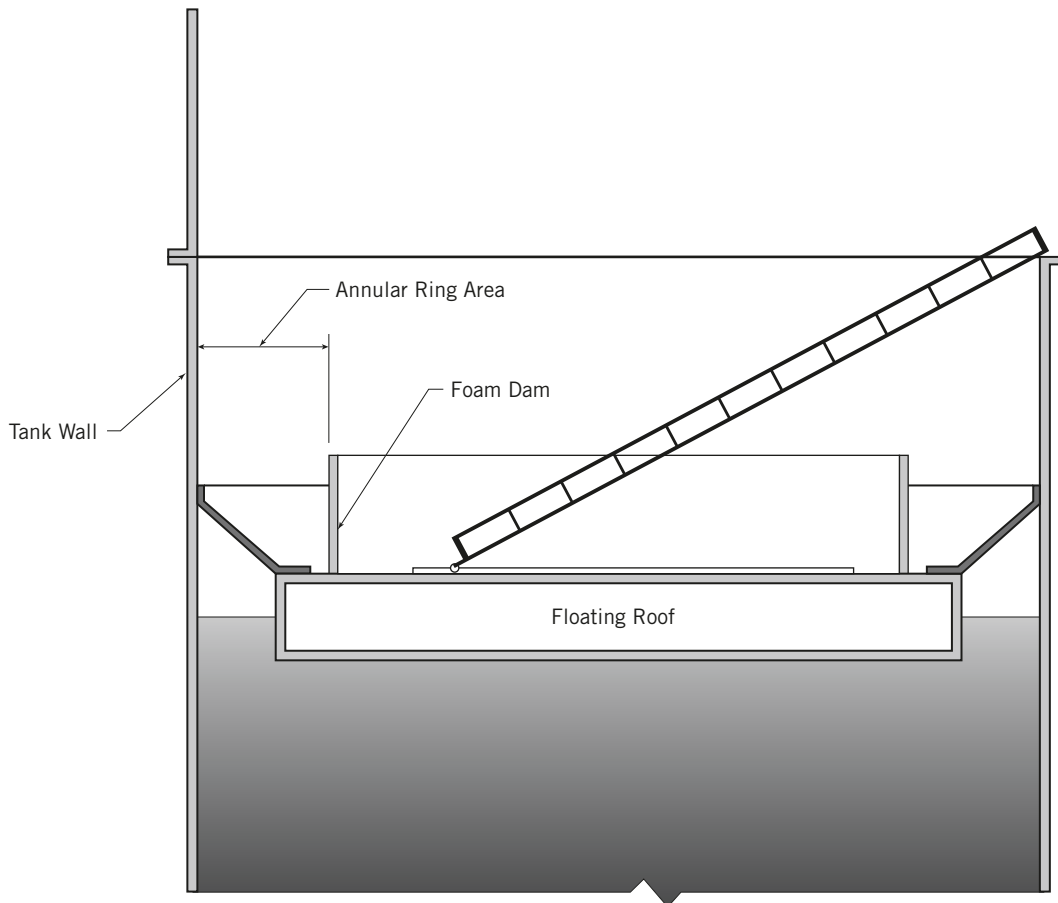



SECTION 7
APPENDIX

Foam Glossary

Adhesive Qualities: The ability to bind together substances of unlike composition. When a foam blanket clings to a vertical surface, it has adhesive qualities. This is required to prevent vapor release from a tank shell, for example.

AFFF (Aqueous Film Forming Foam): A foam liquid containing fluorocarbon surfactants that control the physical properties of water so that it is able to float and spread across the surface of a hydrocarbon fuel.

Airfoam: Foam produced by a physical agitation of a mixture of water, air and a foaming agent. Also called mechanical foam.

Approved: Acceptable to the authority having jurisdiction.

AR-AFFF (Alcohol Resistant - Aqueous Film Forming Foam): A specially formulated foam concentrate for use on alcohols and other polar solvents.

ATC: Alcohol Type Concentrate a registered trademark of SOLBERG or its affiliates.

Authority Having Jurisdiction (AHJ): An organization, office or individual responsible for enforcing the requirements of a code or standard, or for approving equipment, materials, an installation, or a procedure.

Boilover: Violent ejection of flammable liquid from its container caused by the vaporization of water beneath the body of liquid. It may occur after a lengthy burning period of products such as crude oil when the heat wave has passed down through the liquid and reaches the water bottom in the storage tank. It will not occur to any significant extent with water-soluble liquids or light products such as gasoline.

Burnback Resistance: The ability of a foam blanket to resist direct flame impingement such as would be evident in a partially extinguished petroleum fire.

Classification of Fire:

- **Class A Fire:** A fire in combustible fuel such as wood and paper, where the cooling effect of water is of first importance in extinguishment.

- **Class B Fire:** A fire involving a flammable liquid, where blanketing or smothering effect is of first importance in extinguishment.
- **Class C Fire:** A fire in live electrical equipment, where use of a non-conducting fire extinguishing agent is of first importance.

Cohesive Quantities: The ability to bind together substances of like composition.

Combustible Liquid: Any liquid having a flash point at or above 100°F (37.8°C).

Combustible Liquid Classification:

- **Class II:** A liquid that has a closed-cup flash point at or above 100°F (37.8°C) and below 140°F (60°C)
- **Class IIIA:** A liquid that has a closed-cup flash point at or above 140°F (60°C), but below 200°F (93°C)
- **Class IIIB:** A liquid that has a closed-cup flash point at or above 200°F (93°C)

Compatibility: The ability of extinguishing agents to be mixed or applied simultaneously.

Concentration: The amount of foam liquid contained in a given volume of foam solution. The type of foam liquid being used determines the percentage of concentration required. For example: 3% AFFF is mixed in a 3% concentration (97 parts water, 3 parts foam liquid)

Coupled Water-Motor Pump: A correctly designed positive displacement pump in the water supply line coupled to a second, smaller, positive displacement foam concentrate pump to provide proportioning.

Deflector: The device attached to most Type II fixed foam chamber discharge outlets which directs the flow of foam solution down and over a large area of the inside of the storage tank.

Discharge Device: A device designed to discharge water or foam-water solution in a predetermined, fixed, or adjustable pattern. Examples include, but are not limited to, sprinklers, spray nozzles, and hose nozzles.

SECTION 7 – APPENDIX

Air-Aspirating Discharge Devices: Devices specially designed to aspirate and mix air into the foam solution to generate foam. followed by foam discharge in a specific design pattern.

Compressed Air Foam Discharge Device: A device specifically designed to discharge compressed air foam in a predetermined pattern.

Non-Air-Aspirating Discharge Devices: Devices designed to provide a specific water discharge pattern.

Discharge Outlet:

- **Fixed Foam Discharge Outlet:** A device permanently attached to a tank, dike, or other containment structure designed to introduce foam.
- **Type I Discharge Outlet:** An approved discharge outlet that conducts and delivers foam gently onto the liquid surface without submergence of the foam or agitation of the surface.
- **Type II Discharge Outlet:** An approved discharge outlet that does not deliver foam gently onto the liquid surface but is designed to lessen submergence of the foam and agitation of the surface.
- **Eductor (Inductor):** A device that uses the Venturi principle to introduce a proportionate quantity of foam concentrate into a water stream; the pressure at the throat is below atmospheric pressure and will draw in liquid from atmospheric storage.
- **In-Line Eductor:** A Venturi-type proportioning device that meters foam concentrate at a fixed or variable concentration into the water stream at a point between the water source and a nozzle or other discharge device.

Downstream: The direction in which the water is flowing or will flow.

Drainage Rate: The rate at which the solution drains from the foam.

Drainage Time: Time taken for 25% or 50% of the volume of the original foam solution to drain out of the generated foam.

Expansion, Expansion Value, Expansion Ratio: Ratio of the volume of foam to the volume of the foam solution from which it was made:

- **Low Expansion Foam:** Foam which has an expansion ratio less than 20
- **Medium Expansion Foam:** Foam which has an expansion ratio greater than or equal to 20 but less than 200
- **High Expansion Foam:** Foam which has an expansion ratio greater than or equal to 200

Fire:

- **Class A:** A fire in ordinary combustible materials, such as wood, cloth, paper, rubber, and many plastics.
- **Class B:** A fire in flammable liquids. Combustible liquids, petroleum, greases, tars, oils, oil-based paints, solvents, lacquers, alcohols, and flammable gases.
- **Class C:** A fire that involves energized electrical equipment where the electrical resistivity of the extinguishing media is of importance.

Fire-fighting Foam: Aggregate of air filled bubbles formed from a foam solution used for fire-fighting.

Flammable Liquid: A substance which is liquid at ordinary temperatures and pressures and has a flash point below 100°F (38°C).

Flammable Liquid Classification:

- **Class I:** a liquid that has a closed-cup flash point below 100°F (38°C) and a vapor pressure not exceeding 40 psi (2.8 bar) at 100°F (38°C).
- **Class IA:** a liquid that has a closed-cup flash point below 73°F (23°C) and a boiling point below 100°F (38°C).
- **Class IB:** a liquid that has a closed-cup flash point below 73°F (23°C) and a boiling point at or above 100°F (38°C)
- **Class IC:** a liquid that has a closed-cup flash point at or above 73°F (23°C) but below 100°F (38°C).

Flash Back: Reignition of flammable liquid caused by exposure of its vapors to a source of ignition such as a hot metal surface or a spark.

Fluoroprotein Foam: A foam based on natural protein and modified with a selected fluorinated surfactant which is loosely bonded to protein and gives the foam oleophobicity (the ability to shed oil-like products).

Foam: A stable aggregation of bubbles of lower density than oil or water.

- **Compressed Air Foam (CAF):** a homogenous foam produced by the combination of water, foam concentrate, and air or nitrogen under pressure.

Foam Chamber: Fixed foam discharge outlet.

Foam Concentrate: Liquid which is diluted with water to produce foam solution

- **Alcohol-Resistant Foam Concentrate:** a concentrate used for fighting fires on water-soluble materials and other fuels destructive to regular, AFFF, or FFFP foams, as well as for fires involving hydrocarbons.
- **Aqueous Film-Forming Foam Concentrate (AFFF):** a concentrate 'based on fluorinated surfactants plus foam stabilizers to produce a fluid aqueous film for suppressing hydrocarbon fuel vapors and usually diluted with water to a 1 percent, 3 percent, or 6 percent solution.
- **Film-Forming Fluoro-protein Foam Concentrate (FFFP):** A protein-foam concentrate that uses fluorinated surfactants to produce a fluid aqueous film for suppressing hydrocarbon fuel vapors.
- **Film-Forming Foam:** A concentrate that when mixed at its nominal use concentration will form an aqueous film on hydrocarbon fuels. The hydrocarbon fuel typically used as a minimum benchmark for film formation is cyclohexane.
- **Fluoroprotein Foam Concentrate:** a concentrate very similar to protein-foam concentrate but with a synthetic fluorinated surfactant additive.
- **Medium- and High-Expansion Foam Concentrate:**

A concentrate, usually derived from hydrocarbon surfactants, used in specially designed equipment to produce foams having foam to-solution volume ratios of 20:1 to approximately 1000:1.

- **Protein Foam Concentrate:** Concentrate consisting primarily of products from a protein hydrolysate, plus stabilizing additives and inhibitors to protect against freezing, to prevent corrosion of equipment and containers, to resist bacterial decomposition, to control viscosity, and to otherwise ensure readiness for use under emergency conditions.
- **RE-HEALING Foam Concentrate:** An environmentally sustainable fluorosurfactant and fluoropolymer-free foam concentrate used to effectively extinguish Class B hydrocarbon fuel fires.
- **Synthetic Foam Concentrate:** Concentrate based on foaming agents other than hydrolyzed proteins and including aqueous film-forming foam (AFFF) concentrates, medium- and high expansion foam concentrates, and other synthetic foam concentrates.
- **Other Synthetic Foam Concentrate:** A concentrate based on hydrocarbon surface active agents and listed as a wetting agent, foaming agent, or both.

Foam Concentrate Type: A classification of a foam concentrate that includes the chemical composition as defined under foam concentrate, including the use percentage, the minimum usable temperature, and the fuels on which the concentrate is effective.

Foam Generators:

- **Foam Generators (Aspirator Type):** Foam generators, fixed or portable, in which jet streams of foam solution aspirate sufficient amounts of air that is then entrained on the screens to produce foam, and which usually produce foam with expansion ratios of not more than 250:1.
- **Foam Generators (Blower Type):** Foam generators, fixed or portable, in which the foam solution is discharged as a spray onto screens through which an air stream developed by a fan or blower is passing.

Foam Injection:

SECTION 7 – APPENDIX

- **Semi-subsurface Foam Injection:** Discharge of foam at the liquid surface within a storage tank from a floating hose that rises from a piped container near the tank bottom
- **Subsurface Foam Injection:** Discharge of foam into a storage tank from an outlet near the tank bottom.

Foam Maker: A device designed to introduce air into a pressurized foam solution stream.

Foam Solution: Solution of foam concentrates in water in the correct proportions

- **Premixed Foam Solution:** Solution produced by introducing a measured amount of foam concentrate into a given amount of water in a storage tank.

Foam Stability: The relative ability of a foam to withstand spontaneous collapse or breakdown from external causes, such as heat or chemical reaction.

Foam System Types:

- **Compressed Air Foam System (CAFS):** A system employing compressed air foam discharge devices or hoses attached to a piping system through which foam is transported from a mixing chamber. Discharge of CAFS begins with automatic actuation of a detection system, or manual actuation that opens valves permitting compressed air foam generated in the mixing chamber, to flow through a piping system and discharged over the area served by the discharge devices or hoses. Hazards that compressed air foam systems are permitted to protect include flammable liquids as defined and combustible liquids. Compressed air foam systems are not permitted to be used on the following fire hazards: (1) Chemicals, such as cellulose nitrate, that release sufficient oxygen or other oxidizing agents to sustain combustion; (2) Energized unenclosed electrical equipment; (3) Water-reactive metals such as sodium, potassium, and NaK (sodium-potassium alloys); (4) Hazardous water-reactive materials, such as triethyl-aluminum and phosphorous pentoxide; and (5) Liquefied flammable gas.
- **Fixed System:** A complete installation in which foam is piped from a central foam station, discharging

through fixed delivery outlets to the hazard to be protected with permanently installed pumps where required.

- **Mobile System:** Any type of foam-producing unit that is mounted on wheels and that is self-propelled or towed by a vehicle and can be connected to a water supply or can utilize a premixed foam solution.
- **Portable System:** Foam-producing equipment, materials, hose, and so forth that are transported by hand.
- **Semi Fixed System:** A system in which the hazard is equipped with fixed discharge outlets connected to piping that terminates at a safe distance.

Foam-Generating Methods: Methods of generation of air foam including hose stream, foam nozzle, and medium and high-expansion generators, foam maker, pressure foam maker (high back pressure or forcing type) , or foam monitor stream.

- **Compressed Air Foam-Generating Method:** A method of generating compressed air foam recognized in this standard using a mixing chamber to combine air or nitrogen under pressure, water, and foam concentrate in the correct proportions. The resulting compressed air foam flows through piping or hoses to the hazard being protected.

Forceful Application: Application (of foam from the test nozzle) directly onto the surface of the fuel.

Friction Loss: The loss of pressure in a flowing stream resulting from resistance to flow imposed by the inside of the pipe or hose and by changes in flow direction such as elbows and tees.

Gentle Application: Application (of foam from the test nozzle) indirectly to the surface of the fuel from a backboard.

Handline: A hose and nozzle that can be held and directed by hand

Head Loss: Pressure necessary to force water up a pipe or hose to a given vertical height above the source of

water pressure.

Heat Resistance: The ability of a foam to withstand exposure to heat.

Hydrocarbon: An organic compound containing only carbon and hydrogen.

Hydrocarbon Pickup: The characteristic of a fuel that is suspended or absorbed by expanded foam.

Hydrophobic: Water hating; having the property of not mixing with water.

Interfacial Tension: Tension within the interface between two immiscible liquids.

Labeled: Equipment or materials to which has been attached a label, symbol, or other identifying mark of an organization that is acceptable to the authority having jurisdiction and concerned with product evaluation, that maintains periodic inspection of production of labeled equipment or materials, and by whose labeling the manufacturer indicates compliance with appropriate standards or performance in a specified manner.

Line Proportioner: A device that siphons foam from a container to form a foam solution.

Listed: Equipment, materials or services included in a list published by an organization that is acceptable to the authority having jurisdiction and concerned with evaluation of products or services, that maintains periodic inspection of production of listed equipment or materials or periodic evaluation of services, and whose listing states that either the equipment, material, or service meets appropriate designated standards or has been tested and found suitable for a specified purpose.

Minimum Operating Pressure: The lowest temperature at which a foam liquid will proportion with venture devices.

Monitor:

- **Fixed Monitor (Cannon):** A device that delivers a large foam stream and is mounted on a stationary support that either is elevated or is at grade.
- **Portable Monitor (Cannon):** A device that delivers

a foam monitor stream and is mounted on a movable support or wheels so it can be transported to the fire scene.

Newtonian Foam Concentrates: Foam concentrates which have a viscosity which is independent of the shear rate.

NFPA Requirements: Standards established for Foam Extinguishing Systems as set forth in the National Fire Protection Association.

Nozzle:

- **Foam Nozzle or Fixed Foam Maker:** A specially designed hose line nozzle or fixed foam maker designed to aspirate air that is connected to a supply of foam solution.
- **Self-Educting Nozzle:** A device that incorporates a venturi to draw foam concentrate through a short length of pipe and/ or flexible tubing connected to the foam supply.

Oleophobic: Oil hating; have the ability to shed gasoline, oil, and similar products.

Pickup: The induction of foam liquid into water stream by venture.

Polar Solvent: A liquid whose molecules possess a permanent electric moment. Examples are amines, ethers, alcohols, esters, aldehydes, and ketones. In fire fighting, any flammable liquid which destroys regular foam is generally referred to as a polar solvent (or is water miscible).

Polymeric Membrane: A thin, durable, cohesive skin formed on a polar solvent fuel surface, protecting the foam bubbles from destruction by the fuel; a precipitation which occurs when a polar solvent foam comes in contact with hydrophilic fuels such as isopropanol, ethanol, and other polar solvents.

Pour point: The lowest temperature at which a foam liquid is fluid enough to pour, generally about 5°F (-15°C) above the freezing point.

Pressure Drop: The net loss in flowing water pressure

SECTION 7 – APPENDIX

between any two points in a hydraulic system. It is the sum of friction loss, head loss, or other losses due to the insertion of an orifice plate, venturi, or other restriction into a section of pipe or hose.

Pressure Foam Maker (High Back Pressure or Forcing Type): A foam maker utilizing the Venturi principle for aspirating air into a stream of foam solution forms foam under pressure.

Product: Another name that can be applied to a flammable liquid, such as polar solvent (alcohol) or hydrocarbon (gasoline, oil, etc.)

Proportioner: The device where foam liquid and water are mixed to form foam solution.

Proportioning: The continuous introduction of foam concentrate at the recommended ratio into the water stream to form foam solution.

- **Balanced Pressure Pump Type Proportioning:**

A foam proportioning system that utilizes a foam pump and valve(s) to balance foam and water pressures at a modified venturi-type proportioner located in the foam solution delivery piping; a foam concentrate metering orifice is fitted in the foam inlet section of the proportioner.

- **In-Line Balanced Pressure Proportioning:** A foam proportioning system utilizing a foam concentrate pump or a bladder tank in conjunction with a listed pressure reducing valve. At all design flow rates, the constant foam concentrate pressure is greater than the maximum water pressure at the inlet to the in-line balanced pressure proportioner. A pressure balancing valve integral to the in-line balanced pressure proportioner regulates the foam concentrate pressure to be balanced to incoming water pressure.

- **Direct Injection Variable Pump Output**

Proportioning: A direct injection proportioning system that utilizes flow meters for foam concentrate and water in conjunction with a variable output foam pump control system.

Proportioning Methods for Foam Systems:

The methods of proportioning used to create the correct solution of water and foam liquid concentrate.

Protein: Complex nitrogen containing organic compounds derived from natural vegetable or animal sources. Hydrolysis products of protein provide exceptionally stable, cohesive, adhesive, and heat-resistant properties to foam.

Protein Foam Liquid: Concentrated solution of hydrolyzed protein to which chemicals are added to obtain fire resistance, freezing point depression, and other desirable characteristics.

Pseudo plastic Foam Concentrates: Foam concentrates which have a viscosity which decreases with increasing shear rate.

Pump Proportioner (Around-the-Pump Proportioner):

A system that uses a venturi eductor installed in a bypass line between the discharge and suction side of a water pump and suitable variable or fixed orifices to induct foam concentrate from a tank or container into the pump suction line.

Quarter-Life: The time required in minutes for one-quarter of the total liquid solution to drain from the foam. Also referred to as 25% drainage time.

Residual Pressure: The pressure existing in a line at a specified flow.

Sediment: Insoluble particles in the foam concentrate.

Skin Fire: A flammable liquid fire, such as a spill on a solid surface, where the liquid is not present in a depth exceeding 1 inch.

Soluble: The ability to become readily dissolved or mixed with.

Solution: Same as foam solution.

Spray Pattern: The pattern produced by a widely divergent flow of fully formed subdivided foam, the pattern varying with the nozzle pressure and the adjustment of the spray-creating device.

Spreading Coefficient: A value which indicates the

ability of one liquid to spread spontaneously across the surface of another.

Standard: A document, the main text of which contains only mandatory provisions using the word “shall” to indicate requirements and which is in a form generally suitable for mandatory reference by another standard or code or for adoption into law. Non-mandatory provisions shall be located in an appendix, annex, footnote or fine-print note and are not to be considered a part of the requirements of a standard.

Static Pressure: The pressure existing in a line at no flow. This can be considerably higher than the residual pressure.

Stream:

- **Foam Hose Stream:** A foam stream from a handline.
- **Foam Monitor Stream:** A large capacity foam stream from a nozzle that is supported in position and can be directed by one person.

Submergence: Plunging of foam beneath the surface of burning liquid resulting in a partial breakdown of the foam structure and coating of foam with the burning liquid.

Surface Tension: Tension within the interface between a liquid and air.

Surfactant or Surface Active Agent: A chemical that lowers the surface tension of a liquid.

Syndet: Synthetic detergent or cleaning agent.

Tank:

- **Balanced Pressure Bladder Tank:** A foam concentrate tank fitted with an internal bladder that uses waterflow through a modified venturi-type proportioner to control the foam concentrate injection rate by displacing the foam concentrate within the bladder with water outside the bladder.
- **Pressure Proportioning Tank:** A foam concentrate tank with no bladder that uses waterflow through an orifice to displace the foam concentrate in the tank with water to add foam concentrate through an orifice into a water line at a specified rate. This device is only suitable for foams having a specific gravity of at least 1.15.

Type II Applicator: The NFPA term for a discharge outlet not supplemented with means of delivering foam on the surface of the burning liquid without undue submergence or agitation of the surface of the liquid.

Upstream: Opposite the direction in which the water is flowing or will flow.

Venturi: A constricted portion of a pipe or tube which increases water velocity, thus momentarily reducing its pressure. It is in this reduced pressure area that foam liquid is introduced in many types of proportioning equipment.

CAD Drawing Symbols

TANK, ABOVE GROUND

HORIZONTAL



Indicate Type, Dimensions, Construction, Capacity, Pressurization, and Content.

VERTICAL



Indicate Type, Dimensions, Construction, Capacity, Pressurization, and Content.

TANK, BELOW GROUND.



Indicate Type, Dimensions, Construction, Capacity, Pressurization, and Content.

SPRINKLER RISER



GENERAL VALVE



Indicate Valve Size

VALVE IN PIT



Indicate Valve Size

POST-INDICATOR VALVE



Indicate Valve Size

KEY-OPERATED VALVE



Indicate Valve Size

OS&Y VALVE (OUTSIDE SCREW AND YOKE, RISING STEM)



Indicate Valve Size

INDICATING BUTTERFLY VALVE



Indicate Valve Size

NONINDICATING VALVE (NONRISING-STEM VALVE)



Indicate Valve Size

CHECK VALVE



Indicate Valve Size, Direction of Flow

ALARM CHECK VALVE

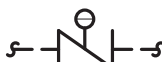

Indicate Valve Size, Direction of Flow

SOLENOID OPERATED VALVE



BACKFLOW PREVENTER - DOUBLE CHECK TYPE



Also Referred to as a Double Check Valve Assembly

BACKFLOW PREVENTER - REDUCE PRESSURE ZONE (RPZ) TYPE



PRESSURE REGULATING VALVE



PRESSURE RELIEF VALVE



FLOAT VALVE



FLOAT VALVE



FIRE PUMP WITH DRIVES



FOAM STORAGE CONTAINER



DETECTION AND CONTROL

MANUAL RELEASE - FOAM SYSTEM



ABORT SWITCH - FOAM SYSTEM



FLOW DETECTOR/SWITCH



PRESSURE DETECTOR/SWITCH



Specify Type - Water, Low Air, High Air, etc.
Symbol Orientation Not to be Changed

LEVEL DETECTOR/SWITCH



Symbol Orientation Not to be Changed

TAMPER DETECTOR



Alternate Term - Tamper Switch

VALVE WITH TAMPER DETECTOR/SWITCH



INDICATING APPLIANCES

BELL (GONG)



WATER MOTOR ALARM (WATER MOTOR GONG)



FOAM SYSTEM

AUTOMATICALLY ACTUATED



MANUAL ACTUATED



SYMBOLS FOR FIRE SPRINKLERS

UPRIGHT SPRINKLER



PENDENT SPRINKLER



UPRIGHT SPRINKLER: NIPPLE UP



PENDENT SPRINKLER: ON DROP NIPPLE



SPRINKLER WITH GUARD



SIDEWALL SPRINKLER



OUTSIDE SPRINKLER



DRY PIPE VALVE

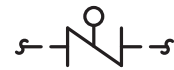

Indicate Valve Size

DRY PIPE VALVE WITH QUICK OPENING DEVICE (ACCELERATOR OR EXHAUSTER)



Indicate Valve Size, Type

DELUGE VALVE



Indicate Valve Size, Type

PERACTION VALVE



Indicate Valve Size, Type

PERACTION VALVE



Indicate Valve Size, Type

FOAM EXTINGUISHER



FOAM REEL STATION



General Reference – Standards And Publications

American Petroleum Institute (API)

API PUB 2021 Guides for Fighting Fires In and Around Petroleum Storage Tanks

European Standard Norm (EN)

EN 13565-1 Fixed Firefighting Systems – Foam Systems - Part 1: Requirements and Test Methods for Components

EN 13565-2 Fixed Firefighting Systems – Foam Systems - Part 2: Design, Construction and Maintenance

EN 1568-1 Fire Extinguishing Media – Foam Concentrates, Part 1: Specification for Medium Expansion Foam Concentrates for Surface Application to Water-immiscible Liquids

EN 1568-2 Fire Extinguishing Media – Foam Concentrates, Part 2: Specification for High Expansion Foam Concentrates for Surface Application to Water-immiscible Liquids

EN 1568-3 Fire Extinguishing Media – Foam Concentrates, Part 3: Specification for Low Expansion Foam Concentrates for Surface Application to Water-immiscible Liquids

EN 1568-4 Fire Extinguishing Media – Foam Concentrates, Part 4: Specification for Low Expansion Foam Concentrates for Surface Application to Water-miscible Liquids

Factory Mutual (FM)

FM5130 Approval Standard for Foam Extinguishing Systems

Federal Aviation Administration (FAA)

AC No. 150/5390-2B Federal Aviation Administration Heliport Design Guide

International Maritime Organization (IMO)

MCS. 1/Circ. 1312 Guidelines for the Performance and Testing Criteria and Surveys of Foam Concentrates for Fixed Foam-Extinguishing Systems

International Organization for Standardization (ISO)

ISO 7203-1 International Standard, Fire Extinguishing Media – Foam Concentrates Part 1

ISO 7203-2 International Standard, Fire Extinguishing Media – Foam Concentrates Part 2

ISO 7203-3 International Standard, Fire Extinguishing Media – Foam Concentrates Part 3

National Fire Protection Association (NFPA)

NFPA 11	Standard for Low-, Medium-, and High-Expansion Foam
NFPA 13	Standard for the Installation of Sprinkler Systems
NFPA 16	Standard for the Installation of Foam-Water Sprinkler and Foam-Water Spray Systems
NFPA 18	Standard on Wetting Agents
NFPA 18A	Standard on Water Additives for Fire Control and Vapor Mitigation
NFPA 25	Standard for the Inspection, Testing, and Maintenance of Water-Based Fire Protection Systems
NFPA 30	Flammable and Combustible Liquids Code
NFPA 409	Standard on Aircraft Hangars
NFPA 412	Standard for Evaluating Aircraft Rescue and Fire-Fighting Foam Equipment
NFPA 418	Standard for Heliports

Underwriters Laboratories, Inc. (UL)

UL Standard 162	Foam Equipment and Liquid Concentrates
UL Subject 139	High-Expansion Foam-Extinguishing Systems Equipment and Concentrates

United States Army Corp of Engineers

ASP TR-74-32	Fire Fighting Foam Proportioning System Technology
--------------	--

United States Department of Defense (DOD)

MIL-F-24385	Military Specification Fire Extinguishing Agent, Aqueous Film Forming Foam (AFFF) Liquid concentrate, for Fresh and Sea Water
UFC 3-600-02	Unified Facilities Criteria (UFC), Operations and Maintenance: Inspection, Testing, and Maintenance of Fire Protection Systems

Around-The-Pump Proportioning Systems

With a typical around-the-pump proportioning system, a portion of the discharge is diverted through a line proportioner. The line proportioner outlet is piped to be suction port of the fire pump. This forms a loop around the fire pump. The foam solution is at the correct ratio and when it is proportioned with the fire pump intake water, the correct foam solution (generally 3% or 6%) is produced. Once this cycle is completed, the proportioning percentage is stabilized and will remain at the correct percentage. The metering orifice must be set properly for the type of foam concentrate being utilized. Automated metering valves, controlled by flow measuring devices, can be used with some around-the-pump system. These devices will adjust for variances in the discharge outputs. Typical applications the around-the-pump proportioning systems can be foam trailers/trucks, crash rescue vehicles, and fixed industrial hazards.

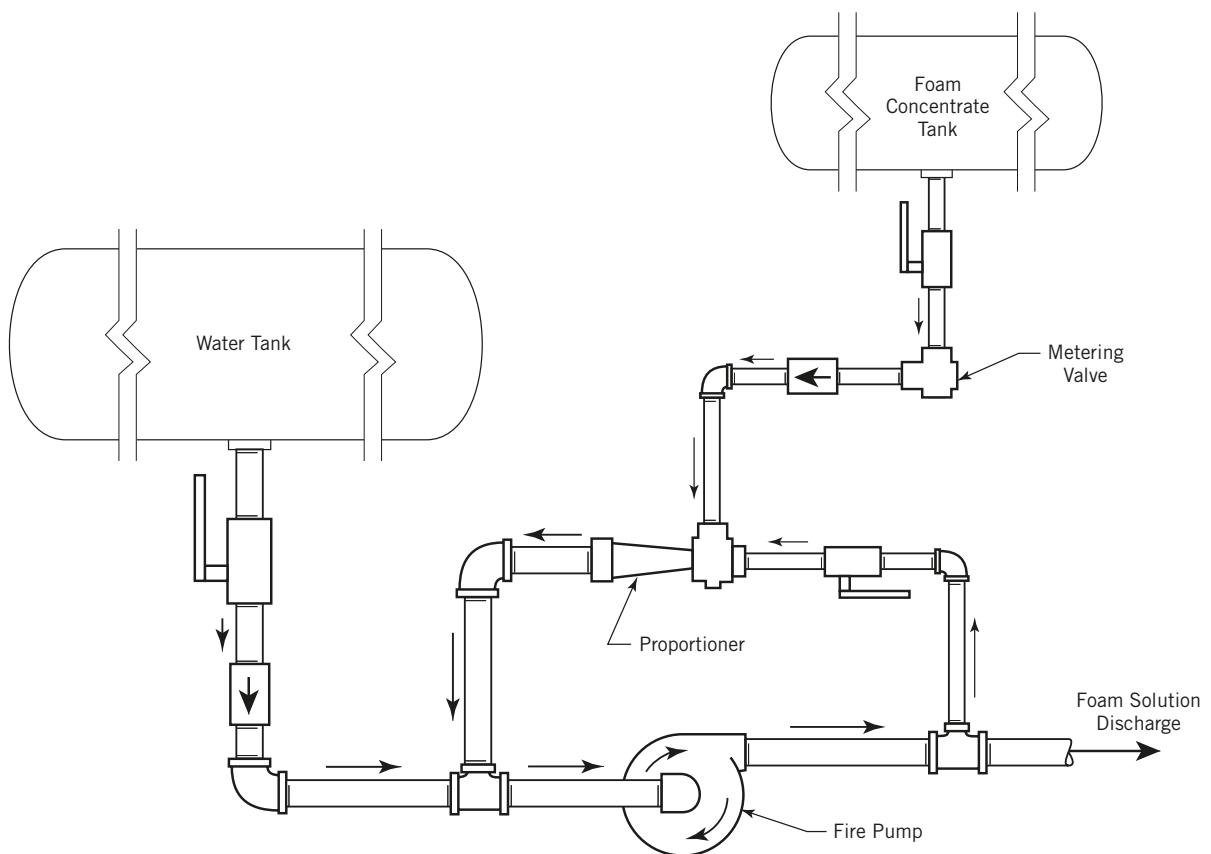

Comparison of Proportioning System Types

Premix

Advantages

- No water supply required
- Very accurate proportioning
- Very simple system requirements

Disadvantages

- Shelf life of premix solution is limited
- The premix supply is limited to the quantity of premix available

Pressure Proportioning

Advantages

- Very simple operation
- Wide flow range
- Little variation in pressure

Disadvantages

- More mechanical system components to maintain
- Potential for increased service and maintenance costs
- Possible dilution of unused foam concentrate

Bladder Tank Proportioning

Advantages

- Not sensitive to pressure variations
- Simple operation
- Proportions properly over wide range of flow
- Normally low maintenance
- Water supply only external power required

Disadvantages

- Possible damage to bladder if not filled correctly
- System must be shut down to recharge
- Capacities are limited
- Limitations between ratio controller and bladder tank

Venturi Type Proportioning

Advantages

- All foam concentrates are acceptable
- Can be recharged during operation
- Simple to operate
- Cost is low

Disadvantages

- Not recommended for use with sprinkler systems
- Back pressures are limited
- Flow rate is fixed
- System requires high water pressure to operate properly
- Proportioner flow must be matched to discharge devices

Balance Pressure Proportioning

Advantages

- Foam concentrate can added during system operation
- All foam concentrate can be utilized
- Wide range of proportioning
- Pressure variations do not effect correct operation

Disadvantages

- An external power source is required
- System pumps and electrical system require maintenance and repair costs
- Generally more expensive on small systems

In-Line Balance Pressure Proportioning

Advantages

- Proportioners can be mounted remotely from the pump system
- Can correctly proportion correctly over wide range of flow
- Proportioners can be sized for best performance of each hazard
- Correct proportioning not sensitive to variations of pressure
- Additional foam concentrate supply can be added during operation
- System can operate with all types of foam concentrate

Disadvantages

- External power source is required
- Generally more costly than other types on smaller systems
- Pumps and electrical equipment may require expensive maintenance

Pick-Up Nozzles

Advantages

- Simple operation
- Very inexpensive
- Can be used with any foam concentrate

Disadvantages

- Generally requires high water pressure
- Operator is required to stay in one location during system operation
- Limited capacities available

Jet Pump Proportioning

Advantages

- Systems can be used with all types of foam concentrates
- Additional foam concentrate can be added during operation
- Very simple operation
- System is low cost

Disadvantages

- The flow rate is fixed
- Has back pressure limitations
- Discharge devices must be matched to the flow of the proportioner
- Requires high water pressure

Around-The-Pump Proportioning

Advantages

- Very simple operation
- Additional foam concentrate can be added during operation

Disadvantages

- Flow discharge is fixed
- The pump suction must be at zero or a little before zero
- The GPM range is limited

UNIT OF MEASUREMENT CONVERSIONS – U.S. TO METRIC

U.S. Unit	Multiply by:	= Metric Equivalent
Area		
Square Foot (ft ²)	0.093	Square Meter (m ²)
Square Inch (in ²)	6.4516	Square Centimeter (cm ²)
Square Inch (in ²)	0.0006	Square Meter (m ²)
Volume		
Gallon (gal.)	3.79	Liter (L)
Cubic Foot (ft ³)	0.028	Cubic Meter (m ³)
Gallon (gal.)	0.00378	Cubic Meter (m ³)
Length		
Inch (in.)	2.54	Centimeter (cm)
Foot (ft.)	0.3048	Meters (m)
Pressure		
Pounds/Square Inch (psi)	6.895	Kilopascals (kPa)
Pounds/Square Inch (psi)	0.06894	Bars
Feet of Water	0.0021	Kilopascals (kPa)
Velocity		
Feet per Second (FPS)	30.48	Centimeters/Second (cm/s)
Feet per Second (FPS)	0.305	Meters/Second (m/s)
Density		
Gallons/Min/Sq Ft (gpm/ft ²)	40.7	Liters/Min/Sq. Meter (Lpm/m ²)
Force		
Pound – Force	4.448	Newton
Temperature		
Degrees Fahrenheit (°F)	$\frac{5(^{\circ}\text{F}-32)}{9}$	Degrees Celsius (°C)

BASIC HYDRAULIC CALCULATIONS

I. CALCULATION OF SPRINKLER AND SPRAY NOZZLE WATER DISCHARGE

Water discharge is determined by the formula:

$$Q = K \sqrt{P} \text{ where: } \begin{array}{l} Q = \text{Flow in gpm} \\ K = \text{Constant for the specific Sprinkler or Nozzle} \\ P = \text{Pressure at the nozzle or sprinkler in psi} \end{array}$$

Example: Find the flow (Q in gpm) of a Viking D2 90° spray nozzle operating at 40 psi

$$Q = 4.97 \sqrt{40} = 31.4 \text{ gpm}$$

II. CALCULATION OF FRICTION LOSS, VELOCITY AND VELOCITY PRESSURE

A. Friction loss through pipe is based on Hazen and Williams formula which is:

$$P = \frac{4.52 \times Q^{1.85}}{C^{1.85} \times d^{4.87}} \text{ where: } \begin{array}{l} P = \text{Friction loss (psi/ft)} \\ Q = \text{Flow in gpm} \\ d = \text{Internal diameter of pipe in inches} \\ C = \text{Constant} \end{array}$$

The fifth column of the pipe tables give the constant of $\frac{4.52}{C^{1.85} \times d^{4.87}}$

for various sizes and types of pipe. To determine the friction loss in one foot of pipe, multiply this constant by $Q^{1.85}$.

Example: Find the friction loss (p-psi/ft.) with a flow (Q) of 10,000 gpm thru 10" Steel Pipe (Schedule 40) using C = 120.

$$P = 8.13 \times 10^{-9} \times Q^{1.85}$$

$$P = 8.13 \times 10^{-9} \times 25,119,000$$

$$P = 0.204 \text{ psi/ft}$$

Effect of Valves and Fittings is commonly expressed as that length of pipe which produces the same friction loss as the valve or fitting. The equivalent pipe length table gives the equivalent length of C = 120 pipe. If the pipe to which the valve or fitting is being made equivalent is other than C = 120, then the equivalent length must be multiplied by the indicated factor.

Example: Find the length of 6" cast iron pipe, unlined class 150 (C = 100), which is equivalent to a 6" deluge valve.

$$33 \text{ ft} \times 0.713 = 23.5 \text{ ft}$$

BASIC HYDRAULIC CALCULATIONS (Continued)

II. CALCULATION OF FRICTION LOSS, VELOCITY AND VELOCITY PRESSURE

B. Velocity of water in pipe may be found by formula:

$$V = \frac{0.4085 Q}{d^2}$$

where: V = Velocity in feet per second
 Q = Flow in gpm
 d = Inside diameter of pipe in inches

The sixth column of the pipe tables give the constant of $\frac{0.4085}{d^2}$

for various sizes and types of pipe. Velocity (fps) may be found by multiplying the constant by flow (Q in gpm).

Example: Find velocity (V-fps) in 10" Schedule 40 steel pipe with a flow (Q) of 10,000 gpm.

$$V = 0.004 \times Q$$

$$V = 0.004 \times 10,000 = 40.0 \text{ fps}$$

C. Velocity pressure is found by the following formula:

$$P_v = \frac{0.001123 Q^2}{d^4}$$

where: P_v = Velocity pressure in psi
 Q = Flow in gpm
 d = Inside diameter of pipe in inches

The seventh column of the pipe tables give the constant of $\frac{0.001123}{d^4}$

for various sizes and types of pipe.

Velocity pressure may be found by multiplying the square of the flow (Q² in gpm²) by this Constant.

Example: Find velocity pressure in 10" Schedule 40 steel pipe with a flow of 10,000 gpm.

$$V.P. = 1.07 \times 10^{-7} \times Q^2$$

$$V.P. = 1.07 \times 10^{-7} \times 10,000^2 = 10.7 \text{ psi}$$

III. PRESSURE DROP DUE TO ELEVATION HEAD

To determine pressure drop, multiply elevation (ft) by 0.433 (psi/ft).

SECTION 7 – APPENDIX

PIPE TABLES

Size (in)	OD (in)	Wall Thickness (in)	I.D. (in)	p (psi/Lin ft) Multiply Q ^{1.85} By		V (fps) Multiply Q By	P _v (psi) Multiply Q ² By
				For C = 120	For C = 100		
Steel Pipe – 1/2-6 Sch. 40							
8-12 Sch. 30							
1/2	0.840	0.109	0.622	6.47 x 10 ⁻³	8.61 x 10 ⁻³	1.056	7.50 x 10 ⁻³
3/4	1.050	0.113	0.824	1.65 x 10 ⁻³	2.19 x 10 ⁻³	0.602	2.44 x 10 ⁻³
1	1.315	0.133	1.049	5.10 x 10 ⁻⁴	6.78 x 10 ⁻⁴	0.371	9.30 x 10 ⁻⁴
1-1/4	1.660	0.140	1.380	1.34 x 10 ⁻⁴	1.78 x 10 ⁻⁴	0.215	3.11 x 10 ⁻⁴
1-1/2	1.900	0.145	1.610	6.33 x 10 ⁻⁵	8.39 x 10 ⁻⁵	0.158	1.68 x 10 ⁻⁴
2	2.375	0.154	2.067	1.87 x 10 ⁻⁵	2.49 x 10 ⁻⁵	0.096	6.17 x 10 ⁻⁵
2-1/2	2.875	0.203	2.469	7.89 x 10 ⁻⁶	1.05 x 10 ⁻⁵	0.067	3.03 x 10 ⁻⁵
3	3.500	0.216	3.068	2.74 x 10 ⁻⁶	3.64 x 10 ⁻⁶	0.0434	1.27 x 10 ⁻⁵
3-1/2	4.000	0.226	3.548	1.35 x 10 ⁻⁶	1.80 x 10 ⁻⁶	0.0325	7.11 x 10 ⁻⁶
4	4.500	0.237	4.026	7.29 x 10 ⁻⁷	9.71 x 10 ⁻⁷	0.0252	4.29 x 10 ⁻⁶
5	5.563	0.258	5.047	2.43 x 10 ⁻⁷	3.23 x 10 ⁻⁷	0.0160	1.74 x 10 ⁻⁶
6	6.625	0.280	6.065	9.91 x 10 ⁻⁸	1.32 x 10 ⁻⁷	0.0111	8.32 x 10 ⁻⁷
8	8.625	0.277	8.071	2.46 x 10 ⁻⁸	3.27 x 10 ⁻⁸	0.0063	2.65 x 10 ⁻⁷
10	10.750	0.307	10.136	8.13 x 10 ⁻⁹	1.08 x 10 ⁻⁸	0.0040	1.07 x 10 ⁻⁷
12	12.750	0.330	12.090	3.45 x 10 ⁻⁹	4.59 x 10 ⁻⁸	0.0028	5.27 x 10 ⁻⁸
Steel Pipe – 1-3 1/2 Sch. 10 S							
4-8 .188 Wt.							
1	1.315	0.109	1.097	4.10 x 10 ⁻⁴	5.45 x 10 ⁻⁴	0.339	7.78 x 10 ⁻⁴
1-1/4	1.660	0.109	1.442	1.08 x 10 ⁻⁴	1.44 x 10 ⁻⁴	0.196	2.60 x 10 ⁻⁴
1-1/2	1.900	0.109	1.682	5.12 x 10 ⁻⁵	6.81 x 10 ⁻⁵	0.144	1.41 x 10 ⁻⁴
2	2.375	0.109	2.157	1.52 x 10 ⁻⁵	2.02 x 10 ⁻⁵	0.088	5.20 x 10 ⁻⁵
2-1/2	2.875	0.120	2.635	5.75 x 10 ⁻⁶	7.65 x 10 ⁻⁶	0.059	2.34 x 10 ⁻⁵
3	3.500	0.120	3.260	2.04 x 10 ⁻⁶	2.71 x 10 ⁻⁶	0.0384	9.97 x 10 ⁻⁶
3-1/2	4.000	0.120	3.760	1.02 x 10 ⁻⁶	1.36 x 10 ⁻⁶	0.0290	5.63 x 10 ⁻⁶
4	4.500	0.188	4.124	6.49 x 10 ⁻⁷	8.63 x 10 ⁻⁷	0.0240	3.89 x 10 ⁻⁶
5	5.563	0.188	5.187	2.12 x 10 ⁻⁷	2.82 x 10 ⁻⁷	0.0152	1.56 x 10 ⁻⁶
6	6.625	0.188	6.249	8.57 x 10 ⁻⁸	1.14 x 10 ⁻⁷	0.0105	7.38 x 10 ⁻⁷
8	8.625	0.188	8.249	2.22 x 10 ⁻⁸	2.95 x 10 ⁻⁸	0.0060	2.43 x 10 ⁻⁷

PIPE TABLES (Continued)

Size (in)	OD (in)	Wall Thickness (in)	I.D. (in)	p (psi/Lin. ft.) Multiply Q ^{1.85} By	V (fps) Multiply Q By	P _V (psi) Multiply Q ² By
Cast Iron Pipe – Unlined Class 150				For C = 100		
4	4.80	0.35	4.10	9.35 x 10 ⁻⁷	0.024	3.99 x 10 ⁻⁶
6	6.90	0.38	6.14	1.31 x 10 ⁻⁸	0.011	7.92 x 10 ⁻⁷
8	9.05	0.41	8.23	3.14 x 10 ⁻⁸	0.006	2.45 x 10 ⁻⁷
10	11.10	0.44	10.22	1.09 x 10 ⁻⁸	0.0039	1.03 x 10 ⁻⁷
12	13.20	0.48	12.24	4.55 x 10 ⁻⁹	0.0027	5.02 x 10 ⁻⁸
14	15.30	0.51	14.28	2.15 x 10 ⁻⁹	0.0020	2.71 x 10 ⁻⁸
16	17.40	0.54	16.32	1.12 x 10 ⁻⁹	0.0015	1.59 x 10 ⁻⁸
18	19.50	0.58	18.34	6.34 x 10 ⁻¹⁰	0.0012	9.95 x 10 ⁻⁹
20	21.60	0.62	20.36	3.81 x 10 ⁻¹⁰	0.00099	6.55 x 10 ⁻⁹
24	25.80	0.73	24.34	1.60 x 10 ⁻¹⁰	0.00069	3.21 x 10 ⁻⁹
Cast Iron Pipe – Enameline Class 150				For C = 140		
4	4.80	0.41	3.98	5.80 x 10 ⁻⁷	0.026	4.49 x 10 ⁻⁶
6	6.90	0.44	6.02	7.73 x 10 ⁻⁸	0.011	8.57 x 10 ⁻⁷
8	9.05	0.47	8.11	1.81 x 10 ⁻⁸	0.006	2.60 x 10 ⁻⁷
10	11.10	0.50	10.10	6.22 x 10 ⁻⁹	0.004	1.08 x 10 ⁻⁷
12	13.20	0.54	12.12	2.56 x 10 ⁻⁹	0.0028	5.22 x 10 ⁻⁸
14	15.30	0.60	14.09	1.23 x 10 ⁻⁹	0.0020	2.86 x 10 ⁻⁸
16	17.40	0.64	16.13	6.36 x 10 ⁻¹⁰	0.0016	1.66 x 10 ⁻⁸
Cast Iron Pipe – Cement Lined – Class 150				For C = 140		
4	4.80	0.48	3.85	6.82 x 10 ⁻⁷	0.0276	5.13 x 10 ⁻⁶
6	6.90	0.50	5.89	8.60 x 10 ⁻⁸	0.0118	9.36 x 10 ⁻⁷
8	9.05	0.54	7.98	1.96 x 10 ⁻⁸	0.0064	2.78 x 10 ⁻⁷
10	11.10	0.56	9.97	6.62 x 10 ⁻⁹	0.0041	1.14 x 10 ⁻⁷
12	13.20	0.60	11.99	2.70 x 10 ⁻⁹	0.0028	5.45 x 10 ⁻⁸
14	15.30	0.70	13.90	1.31 x 10 ⁻⁹	0.0021	3.02 x 10 ⁻⁸
16	17.40	0.73	15.94	6.74 x 10 ⁻¹⁰	0.0016	1.74 x 10 ⁻⁸
Copper Tube – Type K				For C = 150		
3/4	0.875	0.065	0.745	1.79 x 10 ⁻³	0.736	3.66 x 10 ⁻³
1	1.125	0.065	0.995	4.36 x 10 ⁻⁴	0.413	1.15 x 10 ⁻³
1-1/4	1.375	0.065	1.245	1.46 x 10 ⁻⁴	0.264	4.69 x 10 ⁻⁴
1-1/2	1.625	0.072	1.481	6.29 x 10 ⁻⁵	0.186	2.34 x 10 ⁻⁴
2	2.125	0.083	1.959	1.61 x 10 ⁻⁵	0.106	7.65 x 10 ⁻⁵
2-1/2	2.625	0.095	2.435	5.59 x 10 ⁻⁶	0.069	3.20 x 10 ⁻⁵
3	3.125	0.109	2.907	2.36 x 10 ⁻⁶	0.0483	1.58 x 10 ⁻⁵
3-1/2	3.625	0.120	3.385	1.12 x 10 ⁻⁶	0.0357	8.58 x 10 ⁻⁶
4	4.125	0.134	3.857	5.95 x 10 ⁻⁷	0.0275	5.09 x 10 ⁻⁶
Copper Tube – Type L				For C = 150		
3/4	0.875	0.045	0.785	1.38 x 10 ⁻³	0.663	2.97 x 10 ⁻³
1	1.125	0.050	1.025	3.78 x 10 ⁻⁴	0.389	1.02 x 10 ⁻³
1-1/4	1.375	0.055	1.265	1.36 x 10 ⁻⁴	0.255	4.40 x 10 ⁻⁴
1-1/2	1.625	0.060	1.505	5.82 x 10 ⁻⁵	0.180	2.19 x 10 ⁻⁴
2	2.125	0.070	1.985	1.51 x 10 ⁻⁵	0.1037	7.25 x 10 ⁻⁵
2-1/2	2.625	0.080	2.465	5.26 x 10 ⁻⁶	0.0672	3.05 x 10 ⁻⁵
3	3.125	0.090	2.945	2.21 x 10 ⁻⁶	0.0471	1.50 x 10 ⁻⁵
3-1/2	3.625	0.100	3.425	1.06 x 10 ⁻⁶	0.0348	8.18 x 10 ⁻⁶
4	4.125	0.110	3.905	5.60 x 10 ⁻⁷	0.0268	4.84 x 10 ⁻⁶

PIPE TABLES (Continued)

Size (in.)	O.D. (in.)	Wall Thickness (in.)	I.D. (in.)	p (psi/Lin. ft.) Multiply Q ^{1.85} By	V (fps) Multiply Q By	P _V (psi) Multiply Q ² By
Copper Tube – Type M				For C = 150		
3/4	0.875	0.032	0.811	1.18 x 10 ⁻³	0.621	2.60 x 10 ⁻³
1	1.125	0.035	1.055	3.28 x 10 ⁻⁴	0.367	9.09 x 10 ⁻⁴
1-1/4	1.375	0.042	1.291	1.23 x 10 ⁻⁴	0.245	4.05 x 10 ⁻⁴
1-1/2	1.625	0.049	1.527	5.42 x 10 ⁻⁵	0.175	2.07 x 10 ⁻⁴
2	2.125	0.058	2.009	1.43 x 10 ⁻⁵	0.101	6.91 x 10 ⁻⁵
2-1/2	2.625	0.065	2.495	4.96 x 10 ⁻⁶	0.0656	2.91 x 10 ⁻⁵
3	3.125	0.072	2.981	2.09 x 10 ⁻⁶	0.0460	1.43 x 10 ⁻⁵
3-1/2	3.625	0.083	3.459	1.01 x 10 ⁻⁶	0.0341	7.37 x 10 ⁻⁶
Perma Stran – Class 150				For C = 150		
4	4.500	.110	4.28	3.58 x 10 ⁻⁷	0.022	3.36 x 10 ⁻⁶
6	6.625	.153	6.32	5.37 x 10 ⁻⁸	0.001	7.06 x 10 ⁻⁷
8	8.625	.200	8.23	1.48 x 10 ⁻⁸	0.006	2.45 x 10 ⁻⁷
10	10.750	.259	10.23	5.14 x 10 ⁻⁹	0.0039	1.03 x 10 ⁻⁷
12	12.750	.313	12.12	2.25 x 10 ⁻⁹	0.0028	5.22 x 10 ⁻⁸
Cement Asbestos – Class 150 and 250				For C = 140		
4	* 5.07	* 0.54	† 4.00	5.66 x 10 ⁻⁷	0.0255	4.40 x 10 ⁻⁶
6	7.17	0.66	5.85	8.89 x 10 ⁻⁸	0.0119	9.62 x 10 ⁻⁷
8	9.37	0.76	7.85	2.12 x 10 ⁻⁸	0.0066	2.97 x 10 ⁻⁷
10	11.92	0.96	10.00	6.53 x 10 ⁻⁹	0.0041	1.13 x 10 ⁻⁷
12	14.18	1.09	12.00	2.69 x 10 ⁻⁹	0.0028	5.43 x 10 ⁻⁸
14	16.48	1.24	14.00	1.27 x 10 ⁻⁹	0.0021	2.93 x 10 ⁻⁸
16	18.72	1.36	16.00	6.62 x 10 ⁻¹⁰	0.0016	1.72 x 10 ⁻⁸
18	21.30	1.65	18.00	3.73 x 10 ⁻¹⁰	0.00126	1.07 x 10 ⁻⁸
20	23.64	1.82	20.00	2.23 x 10 ⁻¹⁰	0.00102	7.04 x 10 ⁻⁹
24	28.32	2.16	24.00	9.19 x 10 ⁻¹¹	0.00071	3.39 x 10 ⁻⁹

*—O.D. and W.T. apply to Class 150 only.

†—I.D. same for Class 150 and 250.

SECTION 7 – APPENDIX

EQUIVALENT PIPE LENGTHS

(For Common Fittings and Valves expressed in equivalent feet of pipe C = 120)

Symbol	Pipe Size	3/4	1	1-1/4	1-1/2	2	2-1/2	3	3-1/2	4	5	6	8	10	12
E	Standard Elbow	2	2	3	4	5	6	7	8	10	12	14	18	22	27
MtE	Medium Turn Elbow	2	2	3	3	4	5	6	6	8	10	12	16	19	22
LtE	Long Turn Elbow	1	2	2	2	3	4	5	5	6	8	9	13	16	18
EE	45° Elbow	1	1	1	2	2	3	3	3	4	5	7	9	11	13
T	Tee-Flow Turned 90°	4	5	6	8	10	12	15	17	20	25	30	35	50	60
GV	Gate Valve					1	1	1	1	2	2	3	4	5	6
Cr	Cross-Flow Turned 90°	4	5	6	8	10	12	15	17	20	25	30	35	50	60
ALV	Alarm Valve						10			20		18	35		
DPV	Dry Pipe Valve							10		10		19	27		
DeIV	Deluge Valve					18		29		35		33			
CV	Swing Check Valve									10		11	14		
DkV	Detector Check Valve									14		36	55	45	
FLV	*Flow Control					18		29		35		11			

NOTE: Use above values with C-120. For other valves of "C" multiply the above figures by the following factors:

Value of C	100	120	140	150
Factor	0.713	1.0	1.33	1.51

*If Pressure Regulator is not used.

FRICITION LOSS TABLE – PSI PER LINEAL FOOT – (WATER)

Quick reference for Newtonian Concentrates - Consult Darcy Formula for increased accuracy.

GPM	Nominal Pipe Size (sch 40 black steel I.D.) Hazen-Williams C - 120						
	1" 1.049	1 1/4" 1.380	1 1/2" 1.610	2" 2.067	2 1/2" 2.459	3" 3.068	3 1/2" 3.548
10	0.0361	0.0095	0.0045	0.0013	0.0006	0.0002	0.0001
11	0.0431	0.0113	0.0053	0.0016	0.0007	0.0002	0.0001
12	0.0506	0.0133	0.0063	0.0019	0.0008	0.0003	0.0001
13	0.0587	0.0154	0.0073	0.0022	0.0009	0.0003	0.0002
14	0.0673	0.0177	0.0084	0.0025	0.0011	0.0004	0.0002
15	0.0764	0.0201	0.0095	0.0028	0.0012	0.0004	0.0002
16	0.0861	0.0226	0.0107	0.0032	0.0014	0.0005	0.0002
17	0.0963	0.0253	0.0120	0.0035	0.0015	0.0005	0.0003
18	0.1071	0.0282	0.0133	0.0039	0.0017	0.0006	0.0003
19	0.1184	0.0311	0.0147	0.0044	0.0019	0.0006	0.0003
20	0.1301	0.0342	0.0162	0.0048	0.0021	0.0007	0.0003
21	0.1424	0.0375	0.0177	0.0052	0.0022	0.0008	0.0004
22	0.1552	0.0408	0.0193	0.0057	0.0024	0.0008	0.0004
23	0.1685	0.0443	0.0209	0.0062	0.0027	0.0009	0.0004
24	0.1823	0.0480	0.0226	0.0067	0.0029	0.0010	0.0005
25	0.1966	0.0517	0.0244	0.0072	0.0031	0.0011	0.0005
26	0.2114	0.0556	0.0262	0.0078	0.0033	0.0011	0.0006
27	0.2267	0.0596	0.0281	0.0083	0.0036	0.0012	0.0006
28	0.2425	0.0638	0.0301	0.0089	0.0038	0.0013	0.0006
29	0.2588	0.0681	0.0321	0.0095	0.0041	0.0014	0.0007
30	0.2755	0.0725	0.0342	0.0101	0.0043	0.0015	0.0007
31	0.2927	0.0770	0.0363	0.0108	0.0046	0.0016	0.0008
32	0.3105	0.0817	0.0385	0.0114	0.0049	0.0017	0.0008
33	0.3286	0.0864	0.0408	0.0121	0.0052	0.0018	0.0009
34	0.3473	0.0913	0.0431	0.0128	0.0055	0.0019	0.0009
35	0.3664	0.0964	0.0455	0.0135	0.0058	0.0020	0.0010
36	0.3860	0.1015	0.0479	0.0142	0.0061	0.0021	0.0010
37	0.4061	0.1068	0.0504	0.0149	0.0064	0.0022	0.0011
38	0.4267	0.1122	0.0530	0.0157	0.0067	0.0023	0.0011
39	0.4477	0.1177	0.0556	0.0165	0.0071	0.0024	0.0012
40	0.4691	0.1234	0.0582	0.0172	0.0074	0.0025	0.0012
41	0.4911	0.1291	0.0610	0.0181	0.0078	0.0026	0.0013
42	0.5134	0.1350	0.0637	0.0189	0.0081	0.0028	0.0014
43	0.5363	0.1410	0.0666	0.0197	0.0085	0.0029	0.0014
44	0.5596	0.1472	0.0695	0.0206	0.0088	0.0030	0.0015
45	0.5833	0.1534	0.0724	0.0214	0.0092	0.0031	0.0015
46	0.6075	0.1598	0.0754	0.0223	0.0096	0.0033	0.0016
47	0.6322	0.1663	0.0785	0.0232	0.0100	0.0034	0.0017
48	0.6573	0.1729	0.0816	0.0242	0.0104	0.0035	0.0017
49	0.6829	0.1796	0.0848	0.0251	0.0108	0.0037	0.0018
50	0.7089	0.1864	0.0880	0.0261	0.0112	0.0038	0.0019
51	0.7353	0.1934	0.0913	0.0270	0.0116	0.0040	0.0019
52	0.7622	0.2005	0.0946	0.0280	0.0120	0.0041	0.0020
53	0.7896	0.2077	0.0980	0.0290	0.0125	0.0042	0.0021
54	0.8173	0.2150	0.1015	0.0301	0.0129	0.0044	0.0022
55	0.8456	0.2224	0.1050	0.0311	0.0133	0.0045	0.0022
56	0.8742	0.2299	0.1085	0.0321	0.0138	0.0047	0.0023
57	0.9033	0.2376	0.1121	0.0332	0.0143	0.0049	0.0024
58	0.9329	0.2453	0.1158	0.0343	0.0147	0.0050	0.0025
59	0.9628	0.2532	0.1195	0.0354	0.0152	0.0052	0.0025
60	0.9932	0.2612	0.1233	0.0365	0.0157	0.0053	0.0026

SECTION 7 – APPENDIX

FRICION LOSS TABLE – PSI PER LINEAL FOOT – (WATER) (Continued)

Nominal Pipe Size (sch 40 black steel I.D.) Hazen-Williams C - 120							
GPM	1"	1 1/4"	1 1/2"	2"	2 1/2"	3"	3 1/2"
	1.049	1.380	1.610	2.067	2.459	3.068	3.548
61	1.0241	0.2693	0.1271	0.0377	0.0162	0.0055	0.0027
62	1.0554	0.2776	0.1310	0.0388	0.0167	0.0057	0.0028
63	1.0871	0.2859	0.1350	0.0400	0.0172	0.0058	0.0029
64	1.1192	0.2944	0.1389	0.0412	0.0177	0.0060	0.0030
65	1.1518	0.3029	0.1430	0.0423	0.0182	0.0062	0.0030
66	1.1848	0.3116	0.1471	0.0436	0.0187	0.0064	0.0031
67	1.2182	0.3204	0.1512	0.0448	0.0192	0.0065	0.0032
68	1.2520	0.3293	0.1554	0.0460	0.0198	0.0067	0.0033
69	1.2863	0.3383	0.1597	0.0473	0.0203	0.0069	0.0034
70	1.3210	0.3474	0.1640	0.0486	0.0208	0.0071	0.0035
71	1.3561	0.3567	0.1684	0.0499	0.0214	0.0073	0.0036
72	1.3917	0.3660	0.1728	0.0512	0.0220	0.0075	0.0037
73	1.4277	0.3755	0.1772	0.0525	0.0225	0.0077	0.0038
74	1.4640	0.3851	0.1818	0.0538	0.0231	0.0079	0.0039
75	1.5009	0.3947	0.1863	0.0552	0.0237	0.0081	0.0040
76	1.5381	0.4045	0.1909	0.0566	0.0243	0.0083	0.0041
77	1.5757	0.4144	0.1956	0.0579	0.0249	0.0085	0.0042
78	1.6138	0.4244	0.2003	0.0593	0.0255	0.0087	0.0043
79	1.6523	0.4346	0.2051	0.0608	0.0261	0.0089	0.0044
80	1.6912	0.4448	0.2100	0.0622	0.0267	0.0091	0.0045
82	1.7702	0.4656	0.2198	0.0651	0.0279	0.0095	0.0047
84	1.8509	0.4868	0.2298	0.0681	0.0292	0.0099	0.0049
86	1.9333	0.5085	0.2400	0.0711	0.0305	0.0104	0.0051
88	2.0173	0.5306	0.2504	0.0742	0.0318	0.0108	0.0053
90	2.1029	0.5531	0.2611	0.0773	0.0332	0.0113	0.0056
92	2.1902	0.5760	0.2719	0.0805	0.0346	0.0118	0.0058
94	2.2791	0.5994	0.2829	0.0838	0.0360	0.0122	0.0060
96	2.3696	0.6232	0.2942	0.0871	0.0374	0.0127	0.0063
98	2.4618	0.6475	0.3056	0.0905	0.0389	0.0132	0.0065
100	2.5555	0.6721	0.3173	0.0940	0.0403	0.0137	0.0068
110	3.0483	0.8017	0.3784	0.1121	0.0481	0.0164	0.0081
120	3.5806	0.9417	0.4445	0.1317	0.0565	0.0192	0.0095
130	4.1521	1.0920	0.5155	0.1527	0.0655	0.0223	0.0110
140	4.7623	1.2525	0.5912	0.1751	0.0752	0.0256	0.0126
150	5.4106	1.4230	0.6717	0.1989	0.0854	0.0291	0.0143
160	6.0968	1.6035	0.7569	0.2242	0.0962	0.0328	0.0161
170	6.8204	1.7938	0.8467	0.2508	0.1076	0.0366	0.0181
180	7.5811	1.9939	0.9412	0.2787	0.1197	0.0407	0.0201
190	8.3786	2.2036	1.0402	0.3081	0.1322	0.0450	0.0222
200	9.2126	2.4230	1.1437	0.3387	0.1454	0.0495	0.0244
210	10.0828	2.6518	1.2517	0.3707	0.1591	0.0542	0.0267
220	10.9890	2.8902	1.3642	0.4040	0.1734	0.0590	0.0291
230	11.9309	3.1379	1.4812	0.4387	0.1883	0.0641	0.0316
240	12.9082	3.3949	1.6025	0.4746	0.2037	0.0694	0.0342
250	13.9208	3.6613	1.7282	0.5118	0.2197	0.0748	0.0368
260	14.9685	3.9368	1.8583	0.5504	0.2362	0.0804	0.0396
270	16.0509	4.2215	1.9927	0.5902	0.2533	0.0862	0.0425
280	17.1680	4.5153	2.1313	0.6312	0.2710	0.0922	0.0454
290	18.3195	4.8181	2.2743	0.6736	0.2891	0.0984	0.0485
300	19.5052	5.1300	2.4215	0.7172	0.3078	0.1048	0.0516

HOSE FRICTION LOSS

HOSE FRICTION LOSS (psi per 100 ft.)																			
gpm Flowing	3/4 in. Booster	1 in. Booster	1 1/2 in. Hose	gpm Flowing	1 3/4 in. Hose with 1 1/2 in. Couplings	2 in. Hose with 1 1/2 in. Couplings	2 1/2 in. Hose	3 in. Hose with 2 1/2 in. Couplings	3 in. Hose	gpm Flowing	3 in. Hose with 2 1/2 in. Couplings	3 in. Hose	3 1/2 in. Hose	4 in. Hose	gpm Flowing	3 in. Hose	3 1/2 in. Hose	4 in. Hose	5 in. Hose
10	13.5	3.5		150	22.5	11.2	4.0			450	20.3	17.5	7.9	4.1	750	45.0	20.1	11.4	3.7
20	50.0	12.3	1.2	175	34.0	15.8	6.6			475	22.5	19.3	8.7	4.6	800	50.5	22.7	12.4	4.3
30	105.0	26.0	2.5	200	45.6	20.0	8.9	4.0	3.8	500	25.0	21.2	9.5	5.0	850	56.5	25.4	14.3	4.9
40	180.0	44.0	4.3	225	52.1	22.0	11.5	5.1	4.9	525	27.5	23.2	10.5	5.6	900	63.0	28.2	15.9	5.4
50		67.0	7.1	250	61.0	28.2	13.8	6.3	5.9	550	29.0	25.2	11.5	6.0	950	70.0	31.2	17.5	6.0
60		89.0	9.2	275		33.6	16.0	7.6	7.0	575	32.5	27.5	12.4	6.7	1000	76.5	34.3	19.2	6.6
70		118.0	12.3	300		40.0	18.6	9.0	8.2	600	35.0	29.9	13.4	7.2	1100	91.5	41.0	23.0	7.9
80		149.0	15.6	325			22.2	10.7	9.8	625	38.5	32.0	14.4	7.9	1200		49.0	28.5	9.5
90			19.5	350			25.1	12.3	11.0	650	41.0	34.5	15.5	8.5	1300		57.0	30.5	11.0
100			25.5	375			28.4	14.0	12.4	675	44.1	37.0	16.6	9.1	1400		66.5	35.0	13.0
110			29.2	400			33.5	16.0	14.1	700	47.0	39.5	17.7	9.6	1500		74.0	41.5	14.5
120			33.0							725	50.5	42.5	18.9	10.4	2000			68.0	26.0

SECTION 7 – APPENDIX

STRAIGHT BORE DISCHARGE DATA

Discharge Table For Smooth Nozzles – Nozzle Pressure Measured By Pitot Gauge

Nozzle Pressure in psi	Nozzle Diameter in Inches																			
	1/4	5/16	3/8	7/16	1/2	5/8	3/4	7/8	1	1-1/8	1-1/4	1-3/8	1-1/2	1-5/8	1-3/4	1-7/8	2	2-1/4	2-1/2	3
	Gallons Per Minute																			
10	6	9	13	18	23	36	53	71	93	118	146	177	211	248	288	330	376	477	588	848
12	6	10	15	19	25	40	58	78	102	130	160	194	231	271	315	362	412	522	645	928
14	7	11	15	21	27	43	63	84	110	140	173	210	249	293	340	391	445	564	686	1002
16	7	12	16	22	29	46	67	90	118	150	185	224	267	313	364	418	475	603	744	1070
18	7	12	17	24	31	49	71	95	125	159	196	237	283	332	386	444	504	640	790	1136
20	8	13	18	25	33	51	75	101	132	167	206	250	298	350	407	468	532	674	832	1200
22	8	13	19	26	34	54	79	105	139	175	216	263	313	367	427	490	557	707	872	1255
24	8	13	20	27	36	56	82	110	145	183	226	275	327	384	446	512	582	739	910	1311
26	9	14	21	29	37	59	85	115	151	191	235	286	340	400	464	533	606	769	949	1366
28	9	14	21	30	39	61	89	119	157	198	244	297	353	415	481	554	629	799	985	1418
30	10	15	22	31	40	63	92	123	162	205	253	307	365	429	498	572	651	826	1017	1470
32	10	15	23	32	41	65	95	127	167	212	261	317	377	443	514	591	673	854	1050	1515
34	11	16	23	33	43	67	98	131	172	218	269	327	389	457	530	610	693	880	1082	1561
36	11	16	24	34	44	69	100	135	177	224	277	336	400	470	546	627	713	905	1114	1610
38	11	17	25	35	45	71	103	138	182	231	285	345	411	483	561	645	733	930	1144	1650
40	11	18	26	35	46	73	106	142	187	237	292	354	422	496	575	661	752	954	1174	1692
42	11	18	26	36	47	74	109	146	192	243	299	363	432	508	589	678	770	978	1203	1737
44	12	18	27	37	49	76	111	149	196	248	306	372	442	520	603	694	788	1000	1231	1776
46	12	19	28	38	50	78	114	152	200	254	313	380	452	531	617	710	806	1021	1259	1816
48	12	19	28	39	51	80	116	156	205	259	320	388	462	543	630	725	824	1043	1286	1854
50	13	20	29	40	52	81	118	159	209	265	326	396	472	554	643	740	841	1065	1313	1895
52	13	20	29	40	53	83	121	162	213	270	333	404	481	565	656	754	857	1087	1339	1930
54	13	20	30	41	54	84	123	165	217	275	339	412	490	576	668	769	873	1108	1364	1968
56	13	21	30	42	55	86	125	168	221	280	345	419	499	586	680	782	889	1129	1389	2000
58	13	21	31	43	56	87	128	171	225	285	351	426	508	596	692	796	905	1149	1417	2020
60	14	22	31	43	57	89	130	174	229	290	357	434	517	607	704	810	920	1167	1438	2075
62	14	22	32	44	58	90	132	177	233	295	363	441	525	617	716	823	936	1187	1463	2108
64	14	22	32	45	59	92	134	180	237	299	369	448	533	627	727	836	951	1206	1490	2140
66	14	23	33	46	60	93	136	182	240	304	375	455	542	636	738	850	965	1224	1510	2175
68	14	23	33	46	60	95	138	185	244	308	381	462	550	646	750	862	980	1242	1532	2205
70	15	24	34	47	61	96	140	188	247	313	386	469	558	655	761	875	994	1260	1558	2240
72	15	24	34	48	62	97	142	191	251	318	391	475	566	665	771	887	1008	1278	1579	2275
74	15	24	35	48	63	99	144	193	254	322	397	482	574	674	782	900	1023	1296	1600	2300
76	15	24	35	49	64	100	146	196	258	326	402	488	582	683	792	911	1036	1313	1620	2340
78	15	24	36	50	65	101	148	198	261	330	407	494	589	692	803	924	1050	1330	1640	2370
80	16	25	36	50	66	103	150	201	264	335	413	500	596	700	813	935	1063	1347	1665	2400
82	16	25	37	51	66	104	152	204	268	339	418	507	604	709	823	946	1076	1364	1685	2425
84	16	25	37	51	67	105	154	206	271	343	423	513	611	718	833	959	1089	1380	1707	2460
86	16	26	37	52	68	107	155	208	274	347	428	519	618	726	843	970	1102	1396	1723	2485
88	16	26	38	53	69	108	157	211	277	351	433	525	626	735	853	981	1115	1412	1745	2515
90	17	27	39	53	70	109	159	213	280	355	438	531	633	743	862	992	1128	1429	1762	2540
92	17	27	39	54	70	110	161	215	283	359	443	537	640	751	872	1002	1140	1445	1785	2565
94	17	27	39	54	71	111	162	218	286	363	447	543	647	759	881	1012	1152	1460	1802	2600
96	17	27	40	55	72	113	164	220	289	367	452	549	654	767	890	1022	1164	1476	1822	2625
98	17	27	40	55	73	114	166	223	292	370	456	554	660	775	900	1032	1176	1491	1840	2650
100	18	28	41	56	73	115	168	225	295	374	461	560	667	783	909	1043	1189	1506	1860	2680
105	18	29	42	57	75	118	172	230	303	383	473	574	683	803	932	1070	1218	1542	1908	2745
110	19	29	43	59	77	121	176	236	310	392	484	588	699	822	954	1095	1247	1579	1950	2810
115	19	30	43	60	79	123	180	241	317	401	495	600	715	840	975	1120	1275	1615	1995	2875
120	19	31	44	61	80	126	183	246	324	410	505	613	730	858	996	1144	1303	1649	2020	2940
125	20	31	45	63	82	129	187	251	331	418	516	626	745	876	1016	1168	1329	1683	2080	3000
130	20	32	46	64	84	131	191	256	337	427	526	638	760	893	1036	1191	1356	1717	2120	3055
135	21	33	47	65	85	134	195	262	343	435	536	650	775	910	1056	1213	1382	1750	2160	3110
140	21	33	48	66	87	136	198	266	350	443	546	662	789	927	1076	1235	1407	1780	2200	3170
145	21	34	49	68	88	139	202	271	356	450	556	674	803	944	1095	1257	1432	1812	2240	3225
150	22	34	50	69	90	141	205	275	362	458	565	686	817	960	1114	1279	1456	1843	2260	3280
175	24	36	55	74	97	152	218	298	390	494	610	740	883	1030	1200	1380	1572	1985	2460	3540
200	26	40	59	79	104	162	234	318	418	527	653	790	944	1103	1283	1472	1680	2123	2635	3785

Reprinted from the May/June Issue of *ELECTRICAL CONSULTANT*

Understanding Fire Detection Devices

Performance differences must be recognized for correct applications

A fire detection and alarm system is a combination of devices designed to signal an alarm in case of fire. The system may also accomplish fan control, fire-door hold or release, elevator recall, emergency lighting control and other emergency functions. These additional functions supplement the basic system which consists of detection and alarm devices and a central control unit. This article will discuss fire detection systems, with emphasis on operation and application. A future article will address alarm systems.

Detection Devices

Fire is the process of combustion, a chemical reaction producing heat, smoke, flame, light, water vapor, gases and other products. An automatic detection device, such as a heat, smoke or flame detector, will sense the presence of one or more of the above products and generate an alarm signal.

There can also be human discovery of a fire, resulting in manual activation of an alarm device. The fire alarm box, sometimes called a pull-station, is a manual device and can be either coded or noncoded. The noncoded fire alarm box is nothing more than a switch designed to either open or close a circuit when operated. Once operated, however, the switch cannot be externally reset to the normal position. This feature prevents the actuated alarm from being silenced by unauthorized personnel. The coded fire alarm box, upon actuation, transmits a uniquely coded signal over the system. Older boxes used a rotating code wheel, powered by an internal spring or motor, to transmit this signal. Modern systems employ solid-state modules to generate coded signals. Using coded fire alarm boxes, large areas can be protected by zones, thus directing fire fighting personnel to the exact location of the fire.

Heat Detectors

There are two classes of heat detec-

tors: fixed-temperature and rate-of-rise. Variations of these types, such as the rate-compensation detector and the combination detector, are also available.

Rated operating temperature (sometimes referred to as the rated temperature or operation temperature) of heat detectors is the thermal rating of the device. It is the temperature to which the internal heat-sensitive detection element must be heated before it will operate. Typical ratings for fixed-temperature and rate-compensation devices are 135 °F, 175 °F and 250 °F. The actual operating temperature (not an industrially accepted designation, this term is useful when discussing the operating characteristics of heat detectors) is defined as the temperature of the air surrounding the device at the time of its operation. Ideally, the temperatures of the surrounding air and the heat detector should be equal when the device signals an alarm.

Fixed-Temperature Detectors. Fixed-temperature heat detectors will generate an alarm signal when the temperature of the internal detection element reaches its rated operating temperature. Bimetallic strips or discs and fusible links are normally used as detection elements. The bimetallic element type of detector consists of two metals with different coefficients of thermal expansion. When heated, the metals will expand at different rates, resulting in a distortion of the bimetallic element to operate a set of contacts. Another type of heat detector uses fusible links that, when exposed to heat, will melt, allowing a set of springloaded contacts to operate. As the bimetallic elements return to their original position at normal temperature, they are reusable, whereas fusible elements are nonrestorable. Either the detection element or the complete fusible detector must be replaced after each operation.

Heat detectors, as well as many other types of fire detection devices, may be of spot-type or line-type con-

struction. Spot-type detectors are unitary devices with their operating elements in a single enclosure. Spot-type, fixed-temperature detectors include bimetallic thermostats, snap-action disc thermostats, fusible link thermostats and quartzoid bulb thermostats. Line-type detectors consist of lengths of cable or tubing, usually attached to the ceiling of the protected area. Line-type, fixed-temperature detectors include thermostatic or heat sensitive cable and resistance cable.

When a fixed-temperature heat detector operates, the actual operating temperature will invariably be higher than the rated operating temperature. For example, a detector *rated* for 135 °F may not *actually* operate until the temperature of the surrounding air reaches, perhaps, 150 °F when exposed to a gradually increasing fire, or 175 °F for a rapidly increasing fire. This difference between rated operating temperature and actual operating temperature is called thermal lag. By the time the temperature of the detection element reaches its rated operating temperature to generate an alarm signal, the temperature of the surrounding air has gone even higher. The rate of this heat transfer is primarily dependent upon the rate at which the surrounding air itself is being heated.

Rate-Compensated Detectors. Rate-compensation (or rate-anticipation) heat detectors are designed to compensate for thermal lag. When a rate-compensation heat detector operates, the actual operating temperature will be approximately equal to the rated operating temperature, regardless of the rate at which the air is being heated. The rate-compensation detector, as illustrated in Fig. 1, consists of a pair of expansion struts and electrical contacts enclosed by an expansion shell. The expansion shell is exposed to the surrounding air and has a higher coefficient of expansion than the struts. When subjected to a rapidly increasing fire, only the shell will expand, since it is exposed to the heat. This lengthwise expansion of the shell *quickly* relieves compression on the struts and operates the contacts at precisely the rated operating temperature of the device.

When exposed to a gradually increasing fire, on the other hand, the detector heats up uniformly throughout. The shell will expand more than the struts, due to the difference in coefficients of expansion. This action gradually relieves compression on the struts and again operates the contacts at precisely the rated operating temperature of the device.

Rate of Rise Detectors. Rate-of-rise detectors will generate an alarm

Detection Devices

(Continued)

signal when the temperature of the air surrounding the detector rises at a rate in excess of a preselected rate (usually 15 °F per minute). These devices are more responsive than fixed-temperature heat detectors because thermal lag is not a significant factor in the operation of rate-of-rise detectors. One disadvantage of these devices is that they are subject to false alarms when exposed to rapidly increasing temperatures not caused by fire. However, this can be minimized by proper application of the detector.

Line-type rate-of-rise detectors, called pneumatic tube detectors, are also available. A pneumatic tube detector system consists of a continuous loop of tubing located on or near the ceiling of the protected area and operates on the principle of air expansion in a capillary tube instead of in a chamber.

Rate-of-rise detectors should never be located near furnaces, incinerators, freezers, frequently opened exterior doors, or other areas where abrupt changes in ambient temperature may occur. Another disadvantage of rate-of-rise detectors is that they may even fail to operate when exposed to a gradually increasing fire. To overcome this disadvantage, rate-of-rise detectors are combined with fixed-temperature detectors to form a combination heat detector.

Combination Heat Detectors.

Figure 2 illustrates a spot-type combination heat detector. Basically the rate-of-rise portion of the detector consists of electrical contacts and a flexible diaphragm mounted inside an air chamber equipped with a breather valve. The fixed-temperature portion consists of a spring and fusible alloy also mounted inside the chamber. When the unit is exposed to heat from a fire, the air within the chamber will expand, forcing the diaphragm upward. The diaphragm will operate the contacts when sufficient pressure builds up within the chamber. Normal changes in ambient temperature, from the heating system for example, allow sufficient time for the pressure to be relieved through the breather valve, and the detector will not operate.

As discussed previously, rate-of-rise detectors may fail to operate when exposed to a gradually increasing fire. Combination detectors are not susceptible to this problem because the fixed-temperature portion of the detector will "back up" the rate-of-rise portion. When the temperature from a gradually increasing fire is high enough to melt the fusible element, the spring will be released and operate the contacts. The fusible element portion of this

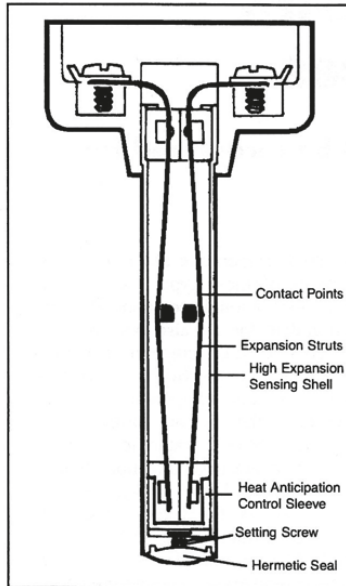

Fig. 1. Rate-compensated heat detector. These units compensate for thermal lag.

detector, of course, is nonrestorable and must be replaced.

Figure 3 is a comparison of the rate of response for fixed-temperature, rate-compensation and rate-of-rise types of heat detectors. It also illustrates the relationship of rated operating temperature, actual operating temperature and thermal lag.

Rules for the proper spacing and location of heat detectors can be found in National Fire Protection Association (NFPA) Standard 72E, Automatic Fire Detectors. Additional data, such as standard ratings, color coding of detectors,

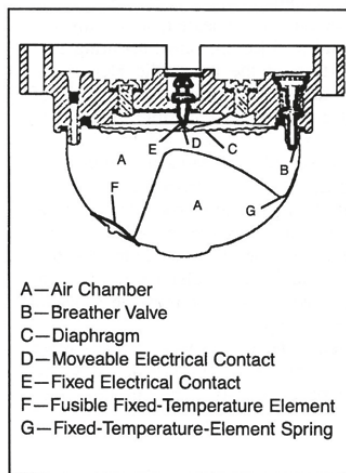

Fig. 2. Combination heat detector. By utilizing both fixed-temperature and rate-of-rise sensors in one unit, these detectors are more responsive to fires.

maintenance and testing requirements, and other application information are also available in the NFPA publication.

Smoke Detectors

NFPA 72E defines smoke as "the totality of the airborne visible or invisible particles of combustion." Visible particles of combustion (e.g., heavy dense smoke from a smoldering fire) consist of a small number of large smoke particles per unit volume, while invisible particles of combustion (e.g., transparent smoke from a rapidly burning fire) consist of a large number of small smoke particles per unit volume. A smoke detector will sense the presence of these visible or invisible particles and generate an alarm signal.

Photoelectric Detectors. Photoelectric (or optical) smoke detectors consist primarily of a photocell and a light source and are normally applied where a fire is expected to generate large amounts of visible particles of combustion. The principle of operation is that smoke entering the path of a light source will block the light and prevent it from striking a photocell, thus generating an alarm signal.

Another principle used is that smoke interfering with a light source will reflect light into a photocell, also generating an alarm signal. Photoelectric detectors can be of spot-type or beam-type construction. The spot-type detector encloses all elements in one small unit while the beam type consists of a light source and photocell located at opposite ends and near the ceiling of the protected area.

Ionization Detectors. Ionization detectors, although capable of detecting the presence of both visible and invisible particles of combustion, are more sensitive to invisible particles. This is because smoke containing a minimum number of particles per unit volume is required to actuate an ionization detector. As previously indicated, invisible particles of combustion contain more smoke particles than do visible particles of combustion. Figure 4 illustrates the principle.

The basic detector consists of a dc source, detection circuitry and an ionization chamber containing a small radioactive alpha source. The dc source, either a battery or a rectifier, maintains an electrical potential between plates P_1 and P_2 as indicated. The air molecules inside the chamber are separated into positive ions and negative electrons by the alpha source, a process known as ionization. Since like charges repel and unlike charges attract, the charged particles between the plates will flow in the directions indicated. When particles of combustion enter the ionization chamber,

Courtesy Notifier Div., Emhart Industries, Inc.

Courtesy Edwards Co.

Detection Devices (Continued)

TYPE OF DETECTOR (135 °F Rating)	SURROUNDING AIR TEMP @ TIME OF ALARM	RATE OF TEMP. RISE FROM 85 °F.	APPROX. TIME TO ALARM	REMARKS
FIXED TEMP.	153 °F	10 °F per minute	6.8 minutes	18 ° Thermal lag.
RATE COMPENSATION	132 °F	10 °F per minute	4.7 minutes	First to operate.
FIXED TEMP.	176 °F	40 °F per minute	2.3 minutes	41 ° Thermal lag.
RATE-OF-RISE	120 °F	40 °F per minute	0.4 minutes	First to operate.
RATE COMPENSATION	125 °F	40 °F per minute	1.0 minute	Second to operate.
FIXED TEMP.	152 °F	Less than 10 °F per minute	8.4 minutes	17 ° Thermal lag.
RATE-OF-RISE	--	Less than 10 °F per minute	Never	Temp. rate not sufficient to operate.
RATE COMPENSATION	138 °F	Less than 10 °F per minute	5.9 minutes	First to operate.

Courtesy Notifier Div., Emhart Industries, Inc.

Fig. 3. Comparison of response times for different types of detectors. Differences are shown between the rated operation temperature and actual operating temperature.

they will attach themselves to the charged particles and reduce their flow. The detector circuitry will sense this flow reduction and generate an alarm signal.

The proper application of smoke detectors is very important. Consider the following points, and follow the manufacturer's recommendations regarding proper location and spacing.

- To avoid false alarms, smoke detectors should not be located in areas where high levels of particles of combustion normally occur, such as garages, boiler rooms or smoking areas.

- Smoke detectors located close to room air supply diffusers may fail to operate, or have reduced sensitivity, because the HVAC air flow will reduce the amount of smoke entering the detection chamber.

- Environmental conditions, such as humidity, barometric pressure and temperature can cause false alarms or loss of sensitivity in smoke detectors. The dual-chamber ionization detector helps avoid this problem and consists of two ionization chambers. One chamber performs the detection function while the second chamber, called a reference chamber,

compensates for variations in humidity, barometric pressure and temperature.

- Care should be exercised when locating smoke detectors outdoors to prevent atmospheric contaminants, such as rain, sleet or snow, from entering the detection chamber.

- Smoke detectors installed in dusty environments may require air filters to prevent false alarms.

Many advances are currently being made in the field of smoke detector technology. Detectors are being made more sensitive to different types of fires and less susceptible to environmental conditions. For example, combination ionization/photoelectric smoke detectors are sensitive to both visible and invisible particles of combustion. These devices capitalize on the advantages of both detector types to provide wide range coverage.

Flame Detectors

Flame is the visible or invisible burning gases or vapor produced by a fire. Flame detectors are line-of-sight devices that will generate an alarm signal when exposed to the radiant energy from a flame. Since this radiant energy travels at the speed of light, flame detectors have the potential for being fast acting. Care must be taken when applying these line-of-sight devices to insure that their effectiveness is not impaired by obstructions such as structural members, equipment, or the presence of dense smoke or gases.

Flame detectors, because of their fast detection capabilities (their reaction time is in the millisecond range) are, in general, only used where a serious hazard exists, such as fuel storage and transfer areas, industrial process areas and situations in which explosions or very rapid fires may occur.

Ultraviolet Detectors. One type of flame detector is the ultraviolet (UV) detector that responds to invisible radiant energy in the ultraviolet range (below 4000 angstroms). Normally, UV detectors are designed to be responsive only in the range of approximately 1800 to 2500 angstroms. This narrow band eliminates false alarms from electric discharge lighting and solar radiation.

UV detectors are not without limitations. One disadvantage is that they may also respond to radiant energy from X-ray machines, arc-welders and lighting. Recent developments, however, have produced UV detectors that are better able to discriminate between an actual flame and other UV sources. Smoke is another problem because it filters UV radiant energy. Consequently, UV detectors should not be used in areas where large amounts of smoke are likely to occur before the appearance of flame.

Despite many recent improvements in UV detector design, arc-welding and smoke interference remain very real and persistent problems. Therefore, careful study of the environment and proper detector location and positioning are very important considerations in the application of this type of detection system.

Infrared Detectors. The infrared (IR) detector utilizes a photovoltaic or photoresistive cell with a filter and lens system and responds to invisible radiant energy, above 7700 angstroms. Like the UV detector, the IR detector is fast acting. The IR detector responds to many heat sources and is, therefore, susceptible to false alarms, even when equipped with sophisticated discrimination schemes. These detectors are also affected by high humidity. For these reasons IR detectors have limited applications and, when used, they are usually installed in industrial facilities.

Flame Flicker and Photoelectric Flame Detectors. These detectors respond to visible radiant energy, which is in the range of 4000 to 7700 angstroms. The photoelectric device consists of a light sensitive photocell that will generate an alarm signal when exposed to the radiant energy of a flame. The flame flicker device, which also operates on the photoelectric principle, contains a filter that permits detection operation only in response to the radiant energy modulated at a frequency characteristic of the flicker of a flame, making the latter device more accurate in responding to the visible radiant energy from a fire.

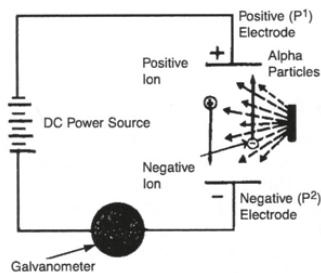

Fig. 4. Operating principal of an ionization detector. These units sense products of combustion.

Detection Devices (Continued)

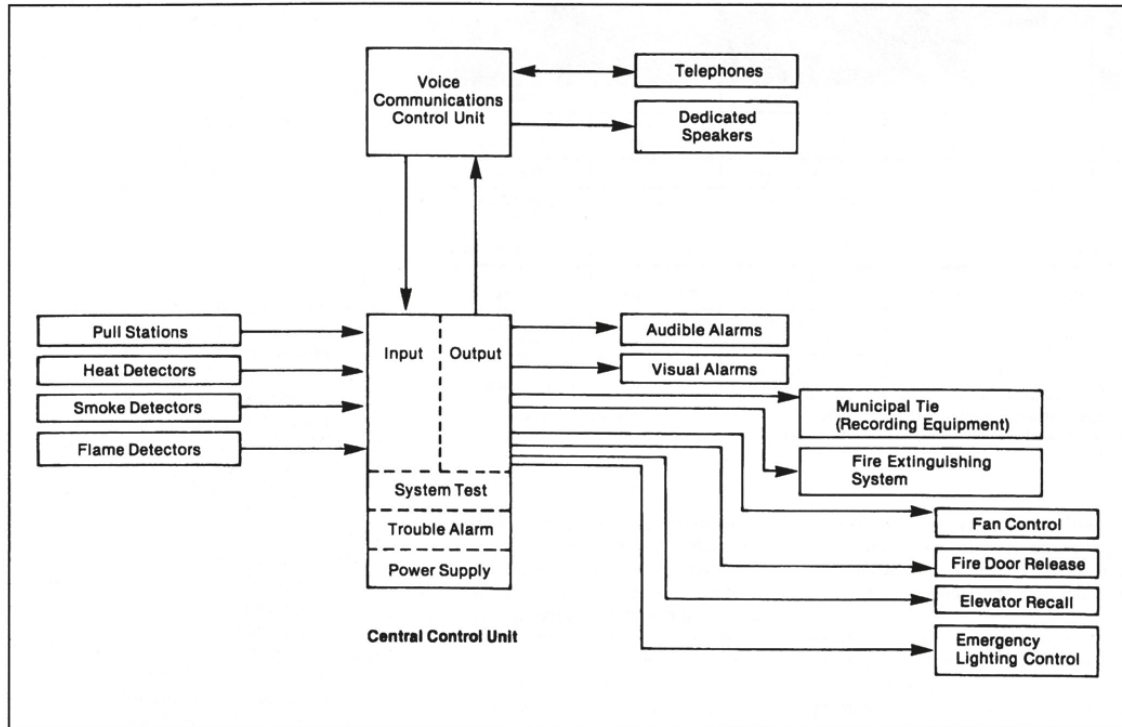

Fig. 5. Typical fire detection, alarm and control/monitoring system. The complete system can range from a simple installation to a complex, sophisticated network that could include security and energy management functions.

Alarm Devices

Alarm devices signal an alarm (either fire or system trouble) when activated. They can be either audible or visual. Audible alarms include bells, horns, klaxons, chimes, buzzers and sirens, while visual alarms include annunciators, strobes and flashing lights. Alarm systems may incorporate solidstate sound reproducers and emergency voice communication using prerecorded or live voice instructions. These systems may also have permanent recording capabilities. Printers that record time, date, location and other pertinent information are normally installed at large facilities or municipalities where a record of all alarms is required.

System Integration

Figure 5 illustrates how the previously discussed devices can be integrated into a typical fire detection and alarm system. Depending upon the application, systems can range from very simple to extremely complex and sophisticated installations. Therefore, all the indicated items may not necessarily be included in all systems.

Modern control units are designed

and fabricated on the modular concept. Each system input and output function (i.e., detection, alarm and fan control) is operated by a solid state module which is interchangeable with other modules. Any number of modules and, therefore, any number of functions, can be incorporated into a system. This approach provides a flexible and reliable system of optimum design and minimum cost regardless of complexity. Furthermore, the modular concept simplifies system maintenance.

Nonfire detection functions, such as intrusion detection and equipment monitoring may also be included for more extensive protection of facilities.

Control Unit

The central control unit serves a five-fold purpose. It (1) receives signals from the detection devices, and operates the alarm and supplemental devices as required; (2) provides a trouble signal in case of system malfunction; (3) provides system test points; (4) provides a point of system control; and (5) supplies electrical power to the system.

Conclusion

The understanding of fire detection and alarm systems is of growing im-

portance to electrical consultants who, with increasing frequency, are designing and specifying such systems into their projects. Using the right detectors, recognizing the prevailing conditions, is important. One very important factor is for the electrical consultant not only to be thoroughly familiar with the local fire codes for their projects, but to recognize possible weaknesses in a code and be able to recommend to a client a fire detection and alarm system that effectively provides protection to a building and its inhabitants. Such an installation can frequently exceed code requirements.

The Author

William E. DeWitt has been employed by the U.S. Army Corps of Engineers Huntsville Div., since 1975. He is involved in the design of large industrial production facilities, in addition to other military construction programs. DeWitt received BSEE and MSEE degrees from the University of Tennessee in 1971 and 1973, respectively, and is a Registered Professional Engineer.

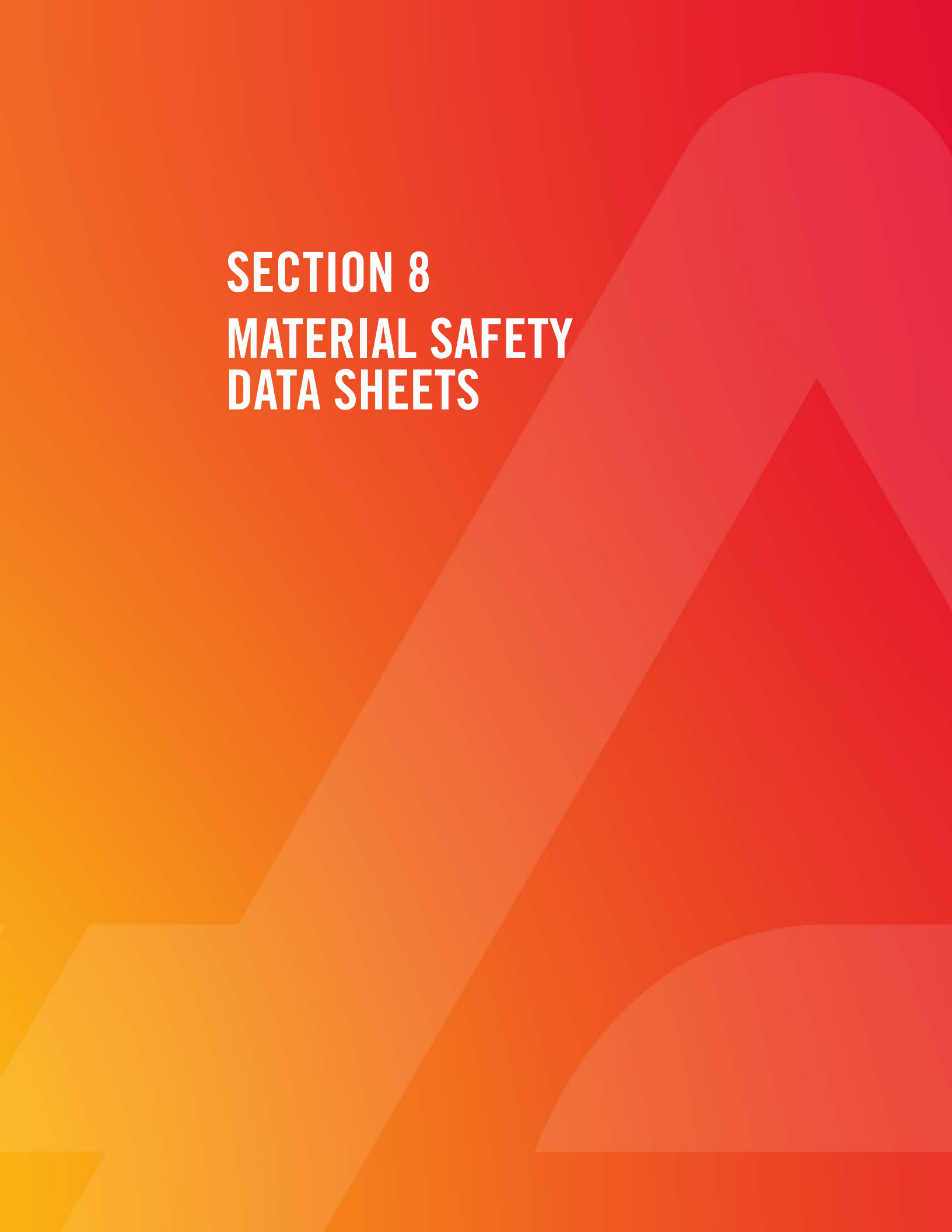
The background features a gradient from yellow-orange on the left to red on the right. Large, semi-transparent geometric shapes, including a large triangle and a rounded rectangle, are layered over the gradient.

SECTION 8
MATERIAL SAFETY
DATA SHEETS

RE-HEALING Foam Concentrates

ARCTIC Foam Concentrates

FIRE-BRAKE Foam Concentrate

Specialized Foam Concentrates

*Visit the **Perimeter Solutions** website for detailed **Technical Bulletin Information**:*

www.perimeter-solutions.com

The background features a gradient from yellow-orange on the left to red on the right. Large, semi-transparent geometric shapes, including a large triangle and a circle, are overlaid on the gradient.

SECTION 9
FM GLOBAL
PROPERTY LOSS
PREVENTION DATA SHEETS

FM Global Property Loss Prevention Data Sheets are engineering guidelines written to help reduce the chance of property loss due to fire, weather conditions and failure of electrical or mechanical equipment, and incorporate loss experience, research results, input from consensus standards committees, equipment manufacturers and others.

FM Global Property Loss Prevention Data Sheets are available as a collection of data sheets or individual sheets grouped by subject (see below) and are available for download at:

<https://www.fmglobal.com/fmglobalregistration>

Data Sheet Collections

- Chemical
- Contractor
- Mining and Metallurgical Refining
- Power Generation

Individual Data Sheets

- 01. Construction
- 02. Sprinklers
- 03. Water Supply
- 04. Extinguishing Equipment
- 05. Electrical
- 06. Boilers and Industrial Heating Equipment
- 07. Hazards
- 08. Storage
- 09. Miscellaneous
- 10. Human Factor
- 11. Systems Instrumentation and Control
- 12. Pressure Vessels
- 13. Mechanical
- 17. Boiler and Machinery Miscellaneous

Data sheet guidelines pertaining to foam-water systems can be located in Section 04: Extinguishing Equipment. A copy of FM Loss Prevention Data Sheet 4-12 Foam-Water Sprinkler Systems is enclosed for reference.



SECTION 10
TECHNICAL DOCUMENTS

Visit the Perimeter Solutions website for detailed Technical Bulletin Information:

www.perimeter-solutions.com