

CONTINUOUS FLOW HOSE REEL

FEATURES

- Grease zert fittings in both supports
- Magna-cast aluminum support
- Manual rewind
- Multiple hose capabilities
- Open side design allows faster hose drying
- Single person operation
- Tension knob

DESCRIPTION

Perimeter Solutions Continuous Flow Hose Reel assemblies are manufactured with magna-cast aluminum supports and brass waterway. It also features a 1.5" (38mm) non-collapsible booster hose and brass 90-degree elbow inlet swivel with male 1.5" (38mm) NST outlet. The carbon steel reel was designed to store and deploy continuous flow hose, which allows liquid to flow while the hose is still on the reel.

APPLICATION

The hose reel assembly may be used for firefighting and/or wash down. Hose reels may also be installed in areas that require supplemental fire protection.

SPECIFICATIONS

Capacity: 1.5" X 100' hose
(38 mm X30 m)
Pressure Rating: 200 psi (14 bar)
Reel Weight: 90 lb (41 kg)

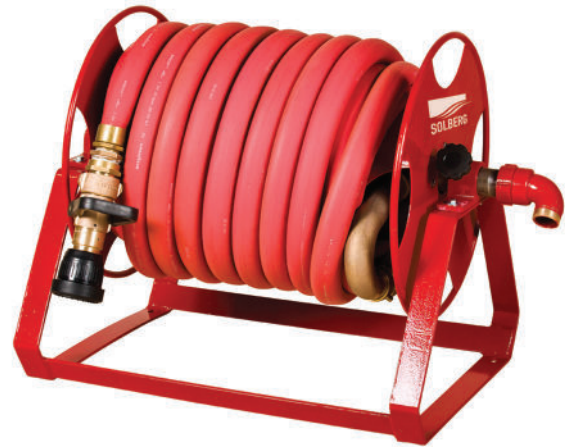

OPTIONS

- Available in stainless steel, galvanized or marine grade aluminum
- Hand crank
- Hand line nozzle with multiple flows
- Vinyl cover
- High mounting stand

CONTINUOUS FLOW HOSE REEL

DIMENSIONAL INFORMATION

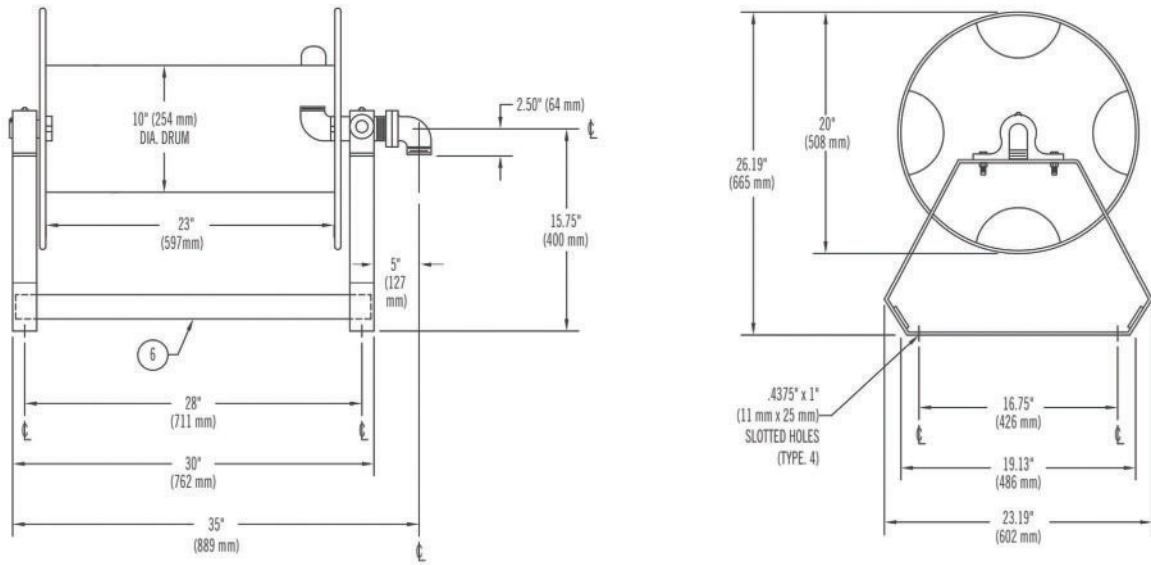

ORDERING INFORMATION

PART NO.	DESCRIPTION	APPROXIMATE SHIPPING WEIGHT	
		lb	kg
35310	Continuous Flow Hose Reel, Model SCHR-50, 50' (15 meter) Hose	142	64
35311	Continuous Flow Hose Reel, Model SCHR-75, 75' (23 meter) Hose	165	75
35312	Continuous Flow Hose Reel, Model SCHR-100, 100' (30 meter) Hose	194	88
35313	Continuous Flow Hose Reel, Model SCHR-150, 150' (46 meter) Hose	246	111



Solutions That Save.

FOR MORE INFORMATION

Contact any of our worldwide Perimeter Solutions Fire Safety offices or visit:

www.Perimeter-Solutions.com

UNITED STATES

10667 Jersey Blvd.
 Rancho Cucamonga, CA 91730
 Tel: +1 800 682 3626
 Tel: +1 909 983 0772
salesfoamusa@perimeter-solutions.com

EMEA

Polígono de Baiña, Parcela 23
 33682 Mieres (Asturias)
 Spain
 Tel: +34 985 24 29 45
salesfoamea@perimeter-solutions.com

ASIA PACIFIC

3 Charles Street
 St Marys NSW 2760 – Australia
 Tel: +61 2 9673 5300
salesfoamapac@perimeter-solutions.com

perimeter-solutions.com

NOTICE PERIMETER SOLUTIONS MAKES NO REPRESENTATIONS OR WARRANTIES AS TO THE COMPLETENESS OR ACCURACY OF THE INFORMATION INCLUDED HEREIN. THE INFORMATION CONTAINED HEREIN IS NOT INTENDED TO PROVIDE REGULATORY, LEGAL OR EXPERT ADVICE RELATING TO THE PRODUCTS, ITS APPLICATION OR USES. NOTHING CONTAINED HEREIN IS TO BE CONSTRUED AS A RECOMMENDATION TO USE ANY PRODUCT, PROCESS, EQUIPMENT OR FORMULATION IN CONFLICT WITH ANY INDUSTRIAL PROPERTY OR INTELLECTUAL PROPERTY RIGHTS, AND PERIMETER SOLUTIONS MAKES NO REPRESENTATION OR WARRANTY, EXPRESS OR IMPLIED, THAT THE USE THEREOF WILL NOT INFRINGE ON ANY INDUSTRIAL PROPERTY OR INTELLECTUAL PROPERTY RIGHTS. NO REPRESENTATIONS OR WARRANTIES, EITHER EXPRESSED OR IMPLIED, OF MERCHANTABILITY, FITNESS FOR A PARTICULAR PURPOSE OR OF ANY OTHER NATURE ARE MADE HEREUNDER WITH RESPECT TO THE INFORMATION CONTAINED HEREIN.