

SOLBERG® FOAM PUMP PROPORTIONER

FEATURES

- **Bronze and stainless steel material construction for performance and durability**
- **Fresh, sea and brackish water compatible**
- **Horizontal or vertical mounted position**

DESCRIPTION

The SOLBERG® Foam Pump Proportioner is a foam solution proportioning device, designed to accurately proportion the foam concentrate into the water stream at both high and low system flow rates. The SOLBERG Foam Pump Proportioner is designed as an integral component of the SOLBERG foam pump proportioning system.

APPLICATION

The SOLBERG Foam Pump Proportioner is designed for open and closed-head foam/water sprinkler systems, foam monitor systems, and other SOLBERG foam discharge devices.

The primary applications for the SOLBERG Foam Pump Proportioner include closed-head foam/water sprinkler systems, protecting risks such as flammable and combustible liquid storage rooms, chemical processing, loading racks, aircraft hangars, and tank farm protection systems using foam chambers.

SPECIFICATIONS

The SOLBERG Foam Pump Proportioner is intended for use with SOLBERG foam concentrates, when used as an integral component of a SOLBERG foam pump proportioning system.

The SOLBERG Foam Pump Proportioner is designed to be installed as a between-the-flange proportioner, in sizes ranging from 2.0" (50 mm) up to and including 10.0" (250 mm) system piping.

The foam concentrate inlet size varies depending on the foam concentrate flow rate and proportioner size selected.

The Foam Pump Proportioner will accurately proportion foam concentrate at flow rates between 30 gpm (110 lpm) up to 6,340 gpm (24000 lpm) for SOLBERG foam concentrates[1].



The SOLBERG Foam Pump Proportioner is manufactured using a bronze body and bronze pressure balancing valve for corrosion resistance. The SOLBERG Foam Pump Proportioner is to be installed with a minimum of 5 pipe diameters (30.0" / 762 mm) of straight pipe both upstream and downstream of the proportioner. The proportioner body is cast with a directional flow arrow on the proportioner body indicating the proper orientation of installation.

[1] The unit will operate with higher flows if the foam system can accept a higher pressure loss.

SOLBERG® FOAM PUMP PROPORTIONER

PERFORMANCE INFORMATION

MODEL SFPP	2.0" (50 MM)	3.0" (76 MM)	4.0" (102 MM)
Size	DN 50	DN 80	DN 100
Foam Inlet	DN 20	DN 25	DN 40
Flow Rate (max)	300 gpm (1100 lpm)	792 gpm (3000 lpm)	1585 gpm (6000 lpm)
Flow Rate (min)	29-58 gpm (110-220 lpm)	66-120 gpm (250-450 lpm)	132-238 gpm (500-900 lpm)
Proportioning Rate	SOLBERG Foam Concentrates	SOLBERG Foam Concentrates	SOLBERG Foam Concentrates
Inlet Pressure (max)	232 psi (16 bar)	232 psi (16 bar)	232 psi (16 bar)
Inlet Pressure (min)	43 psi (3 bar)	43 psi (3 bar)	43 psi (3 bar)
Flange Type	DIN PN16	DIN PN16	DIN PN16
Between Flange Proportions (Dimension A)	1.0" (33 mm)	2.0" (50 mm)	2.3" (58 mm)
Height (Dimension B)	6.0" (160 mm)	10.0" (255 mm)	10.0" (255 mm)
Material	Bronze	Bronze	Bronze

MODEL SFPP	6.0" (152 MM)	8.0" (203 MM)	10.0" (254 MM)
Size	DN 150	DN 200	DN 250
Foam Inlet	DN 50	DN 65	DN 80
Flow Rate (max)	3408 gpm (12900 lpm)	4966 gpm (18800 lpm)	6340 gpm (24000 lpm)
Flow Rate (min)	290-490 gpm (1100-1850 lpm)	422-713 gpm (1600-2700 lpm)	528-911 gpm (2000-3450 lpm)
Proportioning Rate	SOLBERG Foam Concentrates	SOLBERG Foam Concentrates	SOLBERG Foam Concentrates
Inlet Pressure (max)	232 psi (16 bar)	232 psi (16 bar)	232 psi (16 bar)
Inlet Pressure (min)	43 psi (3 bar)	43 psi (3 bar)	43 psi (3 bar)
Flange Type	DIN PN16	DIN PN16	DIN PN16
Between Flange Proportions (Dimension A)	3.0" (74 mm)	3.3" (85 mm)	4.0" (100 mm)
Height (Dimension B)	312.0" (10 mm)	14.0" (355 mm)	17.0" (430 mm)
Material	Bronze	Bronze	Bronze

Note: Over pressurization of 14.5 psi (1 bar) minimum is required on the foam concentrate side.

SOLBERG® FOAM PUMP PROPORTIONER

DIMENSIONAL INFORMATION

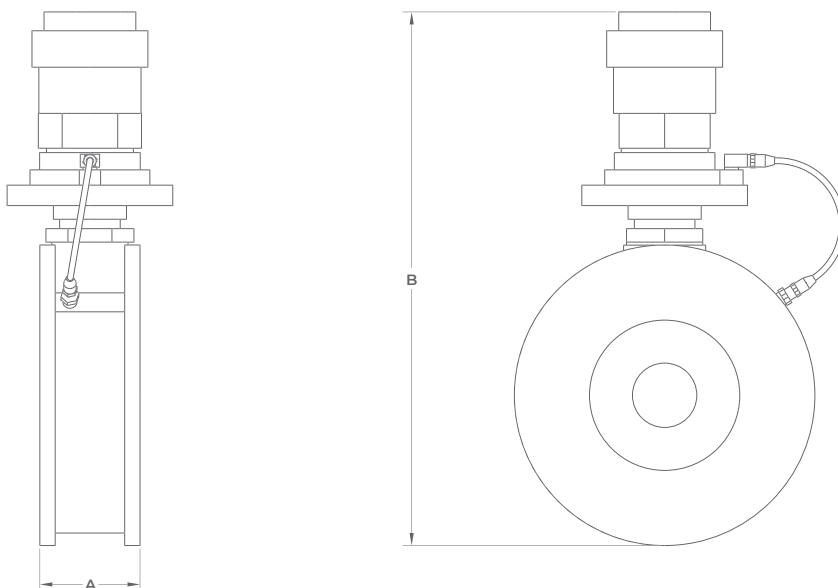

ORDERING INFORMATION

FOAM PUMP PROPORTIONER		SHIPPING WEIGHT	
PART NO.	DESCRIPTION	lb	kg
30204	SOLBERG Foam Pump Proportioner, Model SFPP 2.0" (50 mm)	12	5
30205	SOLBERG Foam Pump Proportioner, Model SFPP 3.0" (76 mm)	15	7
30206	SOLBERG Foam Pump Proportioner, Model SFPP 4.0" (102 mm)	18	8
30207	SOLBERG Foam Pump Proportioner, Model SFPP 6.0" (152 mm)	32	14
30208	SOLBERG Foam Pump Proportioner, Model SFPP 8.0" (203 mm)	60	27
30209	SOLBERG Foam Pump Proportioner, Model SFPP 10.0" (254 mm)	80	36



Solutions That Save.

FOR MORE INFORMATION

Contact any of our worldwide Perimeter Solutions Fire Safety offices or visit:
www.Perimeter-Solutions.com

UNITED STATES

1520 Brookfield Avenue
Green Bay, WI 54313
Tel: +1 920 593 9445
salesfoamusa@perimeter-solutions.com

EMEA

Polígono de Baiña, Parcela 23
33682 Mieres (Asturias)
Spain
Tel: +34 985 24 29 45
salesfoamea@perimeter-solutions.com

ASIA PACIFIC

3 Charles Street
St Marys NSW 2760 – Australia
Tel: +61 2 9673 5300
salesfoamapac@perimeter-solutions.com

perimeter-solutions.com

NOTICE PERIMETER SOLUTIONS MAKES NO REPRESENTATIONS OR WARRANTIES AS TO THE COMPLETENESS OR ACCURACY OF THE INFORMATION INCLUDED HEREIN. THE INFORMATION CONTAINED HEREIN IS NOT INTENDED TO PROVIDE REGULATORY, LEGAL OR EXPERT ADVICE RELATING TO THE PRODUCTS, ITS APPLICATION OR USES. NOTHING CONTAINED HEREIN IS TO BE CONSTRUED AS A RECOMMENDATION TO USE ANY PRODUCT, PROCESS, EQUIPMENT OR FORMULATION IN CONFLICT WITH ANY INDUSTRIAL PROPERTY OR INTELLECTUAL PROPERTY RIGHTS, AND PERIMETER SOLUTIONS MAKES NO REPRESENTATION OR WARRANTY, EXPRESS OR IMPLIED, THAT THE USE THEREOF WILL NOT INFRINGE ON ANY INDUSTRIAL PROPERTY OR INTELLECTUAL PROPERTY RIGHTS. NO REPRESENTATIONS OR WARRANTIES, EITHER EXPRESSED OR IMPLIED, OF MERCHANTABILITY, FITNESS FOR A PARTICULAR PURPOSE OR OF ANY OTHER NATURE ARE MADE HEREUNDER WITH RESPECT TO THE INFORMATION CONTAINED HEREIN.