

# SOLBERG® S-ZF BETWEEN FLANGE INDUCTORS

## FEATURES

- Fixed between-flange installation
- High back pressure
- High suction height
- Can be customized to handle various flow rates
- Compatible with alcohol resistant foam concentrates

## DESCRIPTION

The SOLBERG S-ZF Inductor is used to mix foam concentrate with water when the foam concentrate is supplied from a tank at atmospheric pressure. The S-ZF inductor can be installed in deluge systems where sprinklers are used, such as aircraft hangars and storage facilities. The inductor(s) are connected to the water line.

## APPLICATION

The S-ZF inductor can be installed in all fixed flow systems, especially in areas where deluge nozzles are used such as storage facilities and aircraft hangars.

## OPERATION/INSTALLATION

The S-ZF is installed inside the pipe work between two flanges. The S-ZF works using the venturi principle (i.e., foam concentrate is sucked into the inductor without using a foam pump). Both low and high viscosity foam concentrates can be used in conjunction with the S-ZF. Depending on the requested flow, pressure, foam concentrate type and proportioning ratio, the inductor will be equipped with the exact orifice at the entry of the foam pipe.

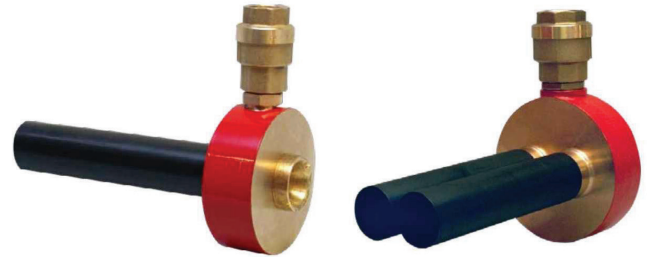

Induction performance and suction height can be adjusted up to a physical limit of approximately 26.0' (8.0 m). To ensure correct proportioning over the designed flow range of the inductor, the minimum water inlet pressure shall be 58 psi (4 bar) during operation of the system.

Note: review inductor dimension tables for information on the minimum recommended length of straight pipe required upstream and downstream from the controller.

## OPTIONAL

SOLBERG S-ZF inductor can be customized to handle a variety of flow rates as well as high viscous alcohol resistant concentrates.

## INDUCTORS WITHOUT BALANCING VALVE

To obtain a 34% pressure drop over the inductor and get the inductors proper function, the system after the inductor shall have a K-factor which is 27% higher than the K-factor of the inductor when using a 3% foam concentrate and 30.5 % higher when using a 6% foam concentrate. If the K-factor, on the system after the inductor, is less than 1.22 x the K-factor of the inductor, the suction ceases completely.

# SOLBERG® S-ZF BETWEEN FLANGE INDUCTORS

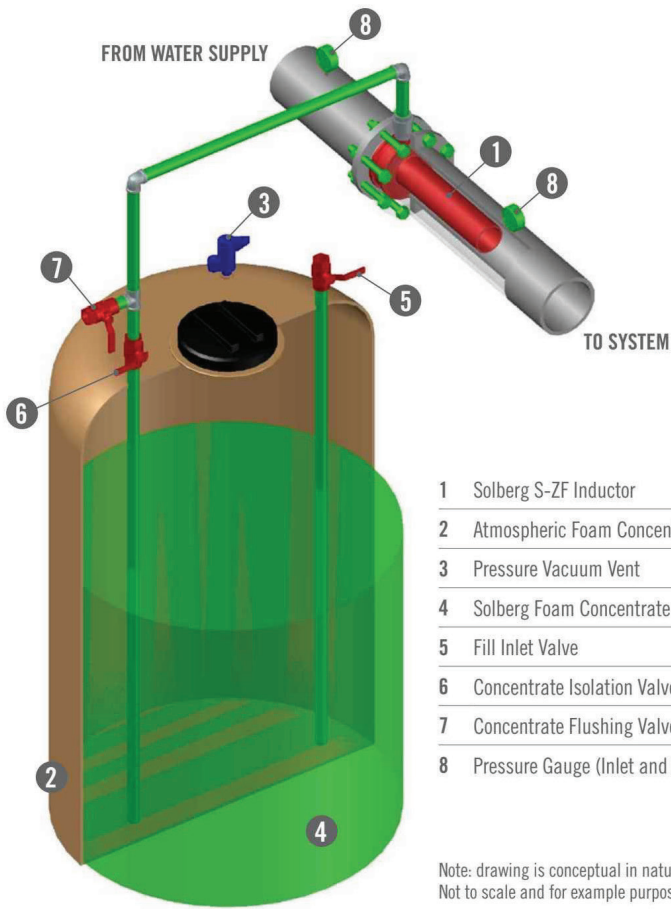

## ORDER REQUIREMENTS

Each inductor is factory calibrated to match the specific system requirements. To ensure that the correct performance is achieved, the following parameters must be defined at time of order placement:

- Inlet pressure
- Total system flow
- Foam type & viscosity
- Mixing percentage
- Suction height
- Horizontal suction pipe length

## ORDERING INFORMATION

### S-ZF BETWEEN FLANGE INDUCTORS

### APPROXIMATE SHIPPING WEIGHT

PART NO.	DESCRIPTION	APPROXIMATE SHIPPING WEIGHT	
		lb	kg
30220	S-ZF Between Flange Inductor, 1.5" (DN40)	7	3
30221	S-ZF Between Flange Inductor, 2.0" (DN50)	9	4
30222	S-ZF Between Flange Inductor, 2.5" (DN65)	9	4
30223	S-ZF Between Flange Inductor, 3.0" (DN80)	14	6
30224	S-ZF Between Flange Inductor, 4.0" (DN100)	16	7
30225	S-ZF Between Flange Inductor, 6.0" (DN150)	47	21
30226	S-ZF Between Flange Inductor, 8.0" (DN200)	89	40
30227	S-ZF Between Flange Inductor, 8.0"-S (DN201)	102	46

# SOLBERG® S-ZF BETWEEN FLANGE INDUCTORS

## INDUCTOR SPECIFICATIONS

Part Number	30220	30221	30222	30223	30224	30225	30226	30227
Size	1.5"	2.0"	2.5"	3.0"	4.0"	6.0"	8.0"	8.0"-S
Max Flow Rate gpm (lpm)	127 (480)	265 (1000)	423 (1600)	529 (2000)	872 (3300)	1744 (6600)	2616 (9900)	4359 (16500)
Min Flow rate gpm (lpm)	22 (80)	32 (120)	64 (240)	96 (360)	146 (550)	291 (1100)	436 (1650)	436 (1650)
Max Inlet pressure psi (bar)	233 (16)	233 (16)	233 (16)	233 (16)	233 (16)	233 (16)	233 (16)	233 (16)
Min Inlet pressure psi (bar)	59 (4)	59 (4)	59 (4)	59 (4)	59 (4)	59 (4)	59 (4)	59 (4)
Pressure drop	35%	35%	35%	35%	35%	35%	35%	35%
K Factor gpm (lpm)	2.9-8.4 (40-120)	4.2-17.4 (60-180)	8.4-27.8 (120-400)	12.5-34.7 (180-500)	19.1-57.2 (275-1000)	37.9-114.3 (550-2000)	56.8-171.4 (825-3000)	56.8-285.6 (1375-5000)
Proportioning rate	1, 3 or 6%	1, 3 or 6%	1, 3 or 6%	1, 3 or 6%	1, 3 or 6%	1, 3 or 6%	1, 3 or 6%	1, 3 or 6%
Suction height (max)	10' (3 m)	10' (3 m)	10' (3 m)	10' (3 m)	10' (3 m)	10' (3 m)	10' (3 m)	10' (3 m)
Flange type PN16*	1.5" (DN40)	2" (DN50)	2.5" (DN65)	3" (DN80)	4" (DN100)	6" (DN150)	8" (DN200)	8" (DN201)
Pipe length up & down stream	5x0	5x0	5x0	5x0	5x0	5x0	5x0	5x0
Weight lbs (kg)	7 (3)	9 (4)	9 (4)	14 (6)	16 (7)	47 (21)	89 (40)	102 (46)
Material	Bronze	Bronze	Bronze	Bronze	Bronze	Bronze	Bronze	Bronze

\* 4.0" to 8.0" size flange fits ANSI #150 but 1.5", 2.0", 2.5" and 3.0" needs machining to fit

## TYPICAL DESIGN LAYOUT

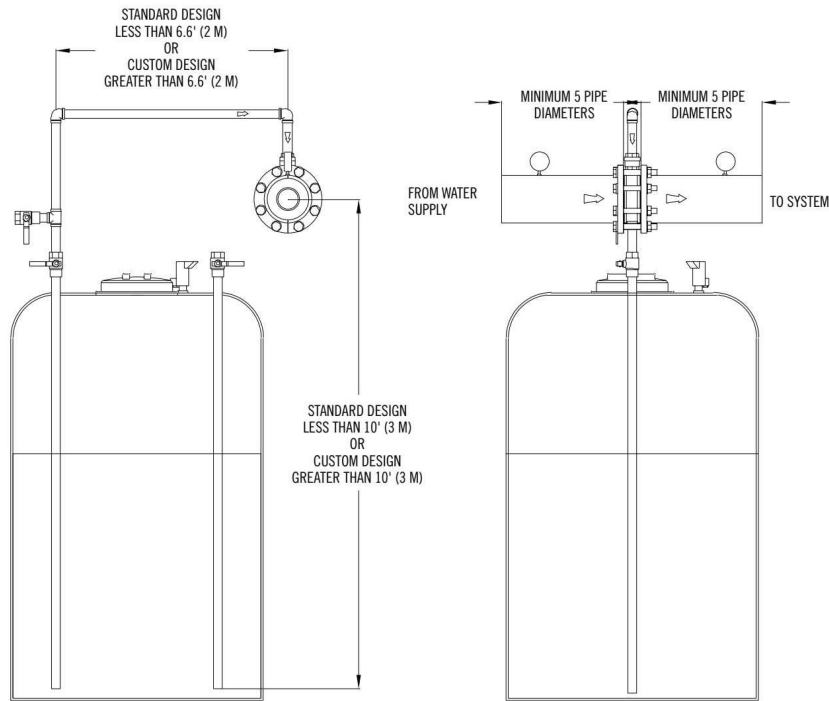

Note: drawing is conceptual in nature. Not to scale and for example purposes only.

## ADVISABLE POSITIONS

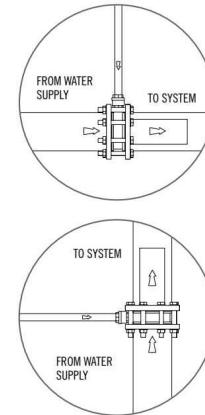

## NON-ADVISABLE POSITION

(Dirt can collect on the check valve in this position)

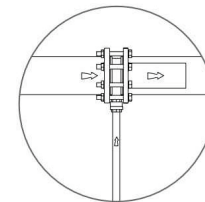

# SOLBERG® S-ZF BETWEEN FLANGE INDUCTORS

## DIMENSIONAL INFORMATION

APPROXIMATE DIMENSIONS Inches (Millimeters)

Part Number	30220	30221	30222	30223	30224	30225	30226	30226
Foam inlet ( A )	3/4"	3/4"	1"	1"	1½"	2"	2½"	2½"
Between Flange Proportions ( B )	1.5 (38)	1.5 (38)	1.8 (45)	2.1 (52)	2.3 (58)	2.8 (70)	3.4 (85)	3.4 (85)
Body size ( C )	3.6 (91)	4.2 (106)	5 (126)	5.7 (143)	6.3 (160)	8.5 (215)	10.7 (270)	10.7 (270)
Height ( D )	4.5 (112)	4.8 (120)	5.4 (137)	5.9 (148)	7.4 (187)	9.1 (230)	13.4 (340)	13.4 (340)
Length ( E )	8.8 (223)	8.8 (223)	14.2 (360)	14.2 (360)	13.6 (343)	13.2 (335)	13 (330)	13 (330)
Length ( F )	0.5 (12)	0.5 (12)	0.6 (15)	0.4 (9)	0.8 (20)	1 (25)	0.8 (20)	0.8 (20)
Total Length ( G )	10.8 (273)	10.8 (273)	16.6 (420)	16.6 (421)	16.6 (421)	17 (430)	17.2 (435)	17.2 (435)

### SINGLE BARREL

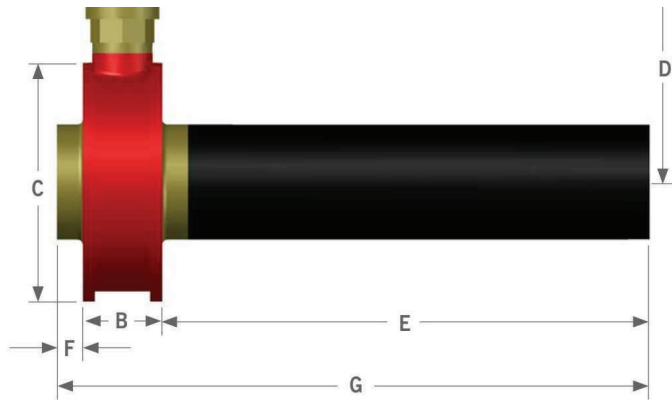

### MULTIPLE BARREL

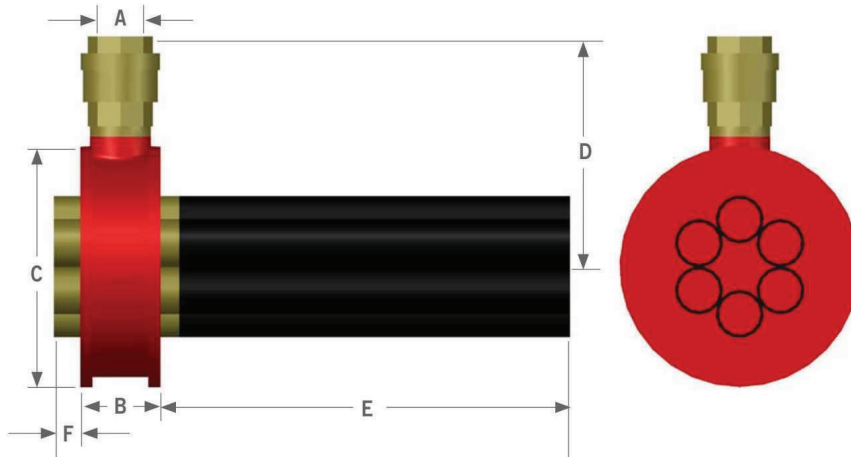

# SOLBERG® S-ZF BETWEEN FLANGE INDUCTORS

## PRESSURE LOSS CURVES

**S-ZF 1.5"**

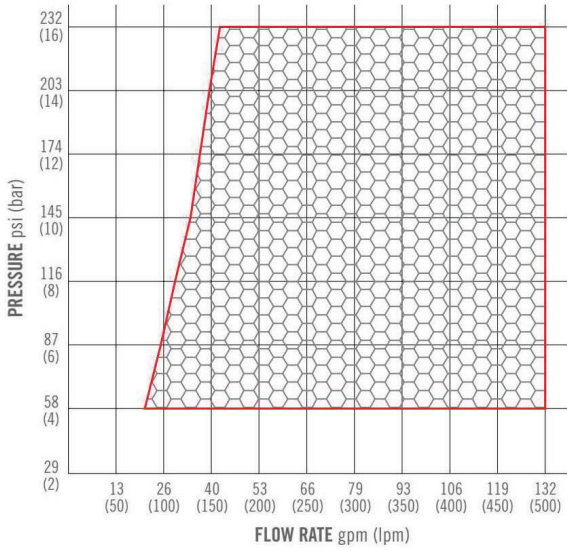

**S-ZF 2.0"**

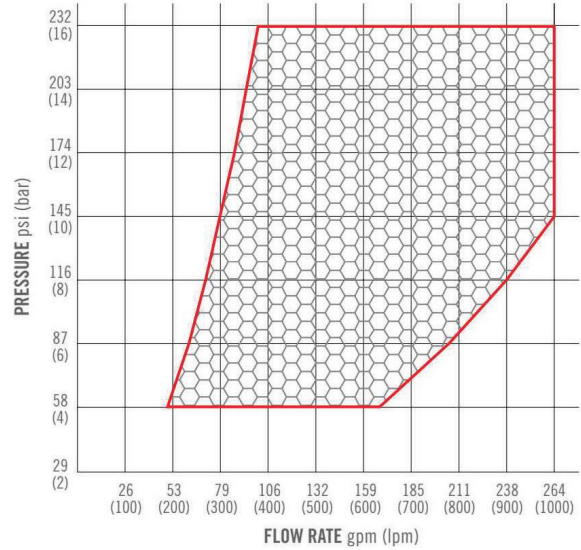

**S-ZF 2.5"**

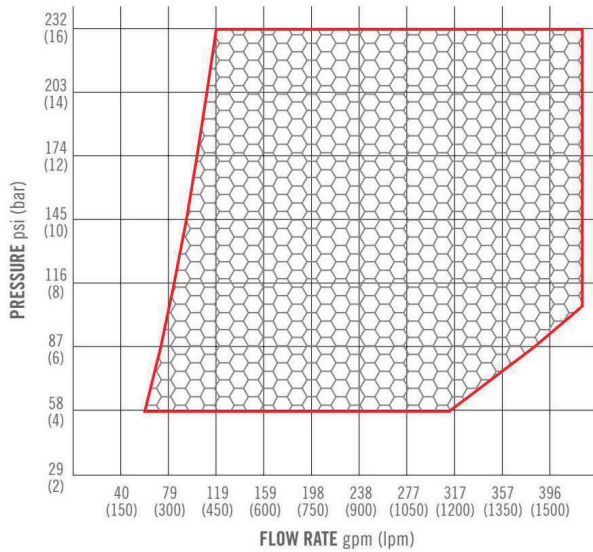

**S-ZF 3.0"**

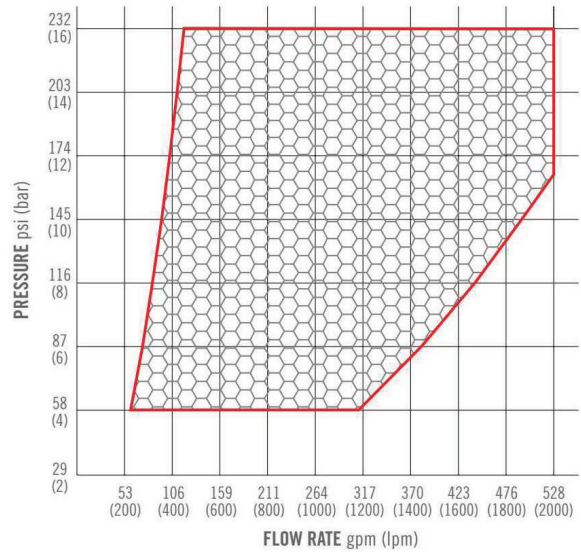

# SOLBERG® S-ZF BETWEEN FLANGE INDUCTORS

## PRESSURE LOSS CURVES

S-ZF 4.0"

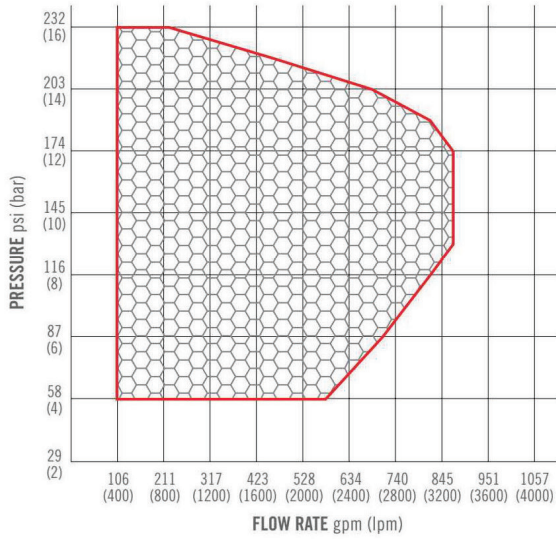

S-ZF 6.0"

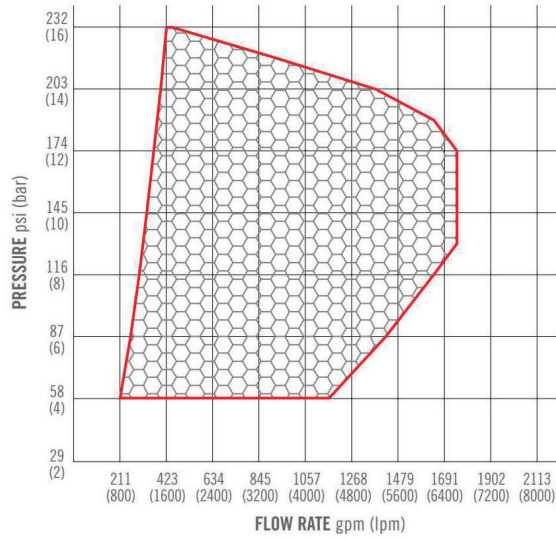

S-ZF 8.0"

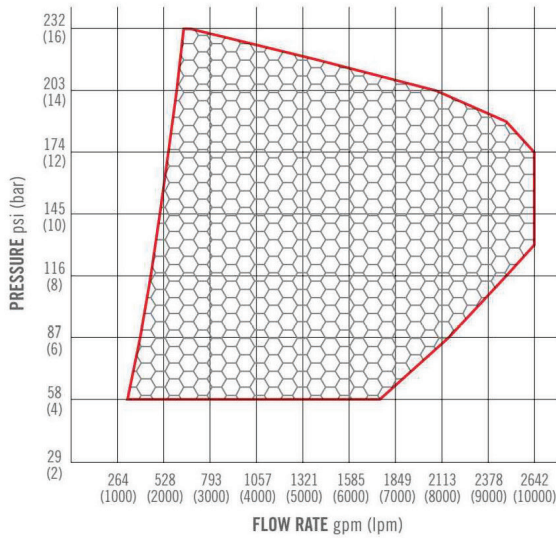

S-ZF 8.0" S

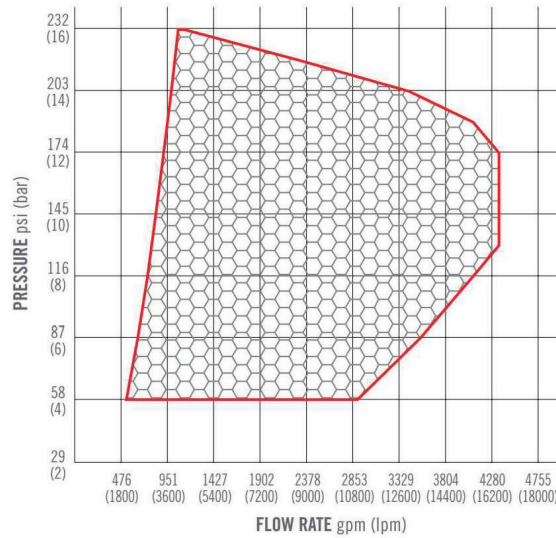

† Not an FM Approved Component



**Solutions That Save.**

**FOR MORE INFORMATION**

Contact any of our worldwide Perimeter Solutions Fire Safety offices or visit:  
[www.Perimeter-Solutions.com](http://www.Perimeter-Solutions.com)

**UNITED STATES**

10667 Jersey Blvd.  
Rancho Cucamonga, CA 91730  
Tel: +1 800 682 3626  
Tel: +1 909 983 0772  
[salesfoamusa@perimeter-solutions.com](mailto:salesfoamusa@perimeter-solutions.com)

**EMEA**

Polígono de Baiña, Parcela 23  
33682 Mieres (Asturias)  
Spain  
Tel: +34 985 24 29 45  
[salesfoamea@perimeter-solutions.com](mailto:salesfoamea@perimeter-solutions.com)

**ASIA PACIFIC**

3 Charles Street  
St Marys NSW 2760 – Australia  
Tel: +61 2 9673 5300  
[salesfoamapac@perimeter-solutions.com](mailto:salesfoamapac@perimeter-solutions.com)

[perimeter-solutions.com](http://perimeter-solutions.com)

**NOTICE** PERIMETER SOLUTIONS MAKES NO REPRESENTATIONS OR WARRANTIES AS TO THE COMPLETENESS OR ACCURACY OF THE INFORMATION INCLUDED HEREIN. THE INFORMATION CONTAINED HEREIN IS NOT INTENDED TO PROVIDE REGULATORY, LEGAL OR EXPERT ADVICE RELATING TO THE PRODUCTS, ITS APPLICATION OR USES. NOTHING CONTAINED HEREIN IS TO BE CONSTRUED AS A RECOMMENDATION TO USE ANY PRODUCT, PROCESS, EQUIPMENT OR FORMULATION IN CONFLICT WITH ANY INDUSTRIAL PROPERTY OR INTELLECTUAL PROPERTY RIGHTS, AND PERIMETER SOLUTIONS MAKES NO REPRESENTATION OR WARRANTY, EXPRESS OR IMPLIED, THAT THE USE THEREOF WILL NOT INFRINGE ON ANY INDUSTRIAL PROPERTY OR INTELLECTUAL PROPERTY RIGHTS. NO REPRESENTATIONS OR WARRANTIES, EITHER EXPRESSED OR IMPLIED, OF MERCHANTABILITY, FITNESS FOR A PARTICULAR PURPOSE OR OF ANY OTHER NATURE ARE MADE HEREUNDER WITH RESPECT TO THE INFORMATION CONTAINED HEREIN.