

FOAM MAKERS

FEATURES

- **Stainless steel construction for corrosive environments**
- **Air inlets covered with stainless steel mesh to protect against blockage and damage**
- **Inlet orifice machined and sized to match specific flow and pressure rates**
- **Multiple sizes available**
- **Supplied with Standard NPT threaded female inlet and male outlet**

DESCRIPTION

Perimeter Solutions Foam Makers (SFM & DT) are available in various models with nominal flow rates ranging from 6 - 200 gpm (25 - 757 lpm) at 30 - 150 psi (2 - 10 bar) with threaded inlets and outlets. The stainless steel discharge tube incorporates a mixing barrel, an orifice plate (sized for the required flow at a given pressure) and an air inlet to allow air into the foam solution stream to generate expanded foam. The foam maker is normally installed in the line of a semi-fixed or fixed foam fire protection system.

APPLICATION

Perimeter Solutions Foam Makers are airaspirating foam discharge devices used primarily for the protection of the seal area of open top floating roof storage tanks and dike areas around storage tanks. Additional applications include protection of spill hazards and diked flammable liquid storage areas.

Foam Makers are used with numerous types of proportioning systems including atmospheric tanks, bladder tanks, balanced pressure pump proportioning systems or line proportioners.

Perimeter Solutions Foam Makers can be used with RE-HEALING, VERSAGARD and ARCTIC foam concentrates for the suppression of Class B flammable liquids.



FLOW RANGE

The flow rate of a Perimeter Solutions Foam Maker is determined by the orifice size and inlet pressure. The flow rates listed in the following table are based on the minimum operating pressure of 30 psi (2 bar) and the maximum operating pressure of 150 psi (10 bar) required for satisfactory operation.

CERTIFICATIONS

- UL Underwriters Laboratories
- FM Approved per Approval Standard 5130

FOAM MAKERS

DIMENSIONAL INFORMATION

MODEL	CONCENTRATE	FLOW RATE (MIN - MAX)	PRESSURE (MIN - MAX)	APPROXIMATE DIMENSIONS Inches (Millimeters)		
				INLET	OUTLET	LENGTH
SFM- 1.5	RE-HEALING RF3, 3%	34 - 68 gpm (129 - 257 lpm)	40 - 150 psi (3 - 10 bar)	1.5 (38)	1.5 (38)	17.0 (432)
SFM - 2.5†		102 - 197 gpm (386 - 746 lpm)	40 - 150 psi (3 - 10 bar)	2.5 (64)	2.5 (64)	28.0 (711)
SFM - 1.5*	ARCTIC 3x3% ATC	35 gpm (132 lpm)	42 psi (3 bar)	1.5 (38)	1.5 (38)	17.0 (432)
SFM - 1.5*		60 - 75 gpm (227 - 284 lpm)	100 - 150 psi (7 - 10 bar)	1.5 (38)	1.5 (38)	17.0 (432)
DT-30, 1.5		25 - 56 gpm (95 - 212 lpm)	98 - 150 psi (7 - 10 bar)	1.5 (38)	1.5 (38)	17.0 (432)
SFM - 2.5		20 gpm (76 lpm)	N/A	2.5 (64)	2.5 (64)	28.0 (711)
DT-30, 1.5	ARCTIC 3x3% CG ATC	20 gpm (76 lpm)	150 psi (10 bar)	1.5 (38)	1.5 (38)	17.0 (432)
DT-30, 1.5	VERSAGARD AS-100	20 - 55 gpm (76 - 208 lpm)	70 - 150 psi (5 - 10 bar)	1.5 (38)	1.5 (38)	17.0 (432)
DT-90, 2.5		28 - 197 gpm (76 - 746 lpm)	40 - 150 psi (3 - 10 bar)	2.5 (64)	2.5 (64)	28.0 (711)

Note: † non-UL Listed, non-FM Approved. * FM Approval Guide hydrocarbon fuels only.

MODEL SFM-1.5

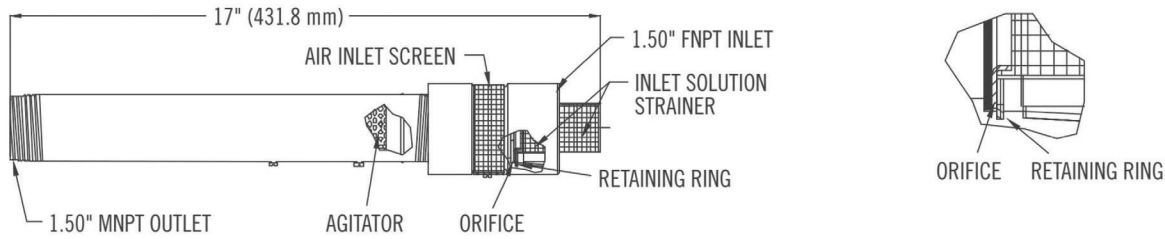

MODEL SFM-2.5

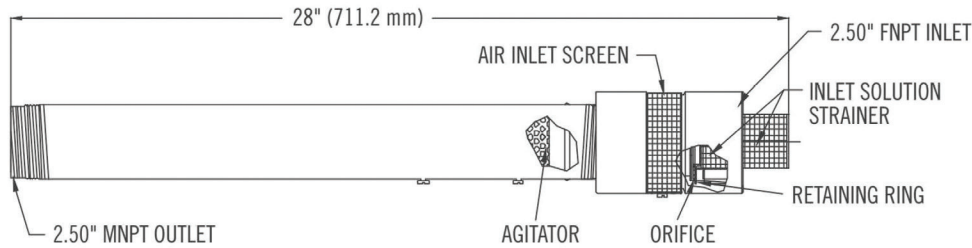

MODEL	"K" FACTOR RANGE
SFM-1.5	1.1 - 5.8
SFM-2.5	14.9 - 15.6
DT-30, 1.5	2.6 - 4.6
DT-90, 2.5	4.4 - 16.1

FOAM MAKERS

TYPICAL DIKED PROTECTION INSTALLATION

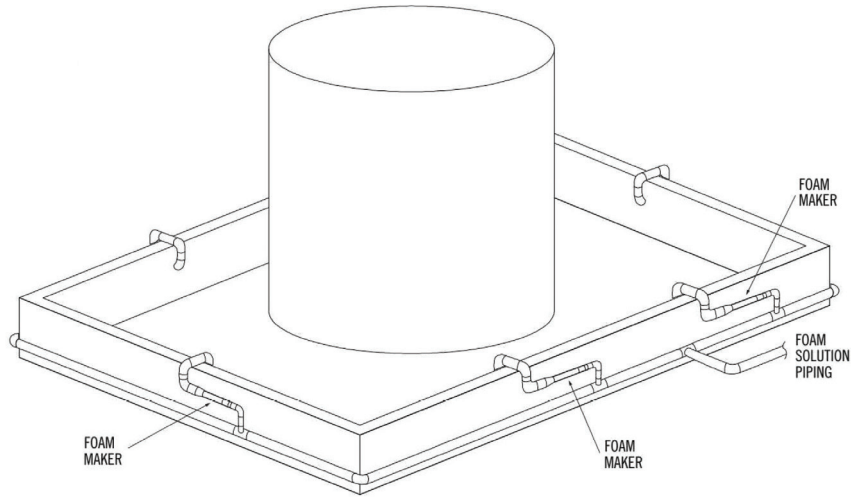

FLOATING ROOF TANK INSTALLATION

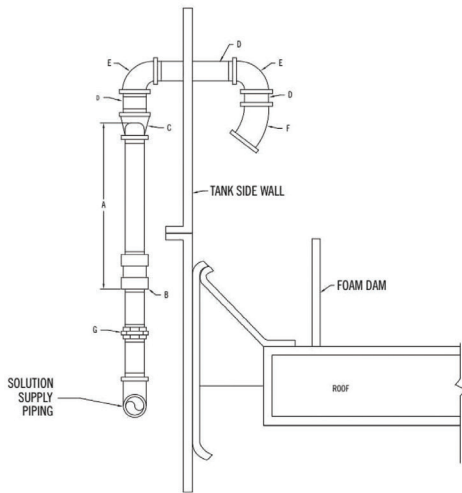

DIKED AREA INSTALLATION

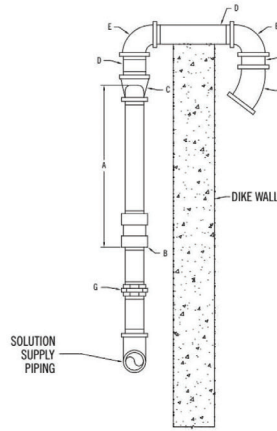

APPROXIMATE DIMENSIONS Inches (Millimeters)

A	B	C	D	E	F	G
SFM - 1.5 (38)	1.5 - 11.5 (38-292) NPT	1.5 x 2.5 (38 x 64) Red. Coup.	2.5 (64) Nipple	2.5 (64) 90° Elbow	2.5 (64) 45° Elbow	1.5 (38) Union
SFM - 2.5 (64)	2.5 - 8 (64-203) NPT	2.5 x 4 (64 x 102) Red. Coup.	4 (102) Nipple	4 (102) 90° Elbow	4 (102) 45° Elbow	2.5 (64) Union
DT-30, 1.5 (38)	1.5 - 11.5 (38 - 292) NPT	1.5 x 2.5 (38 x 64) Red. Coup.	2.5 (64) Nipple	2.5 (64) 90° Elbow	2.5 (64) 45° Elbow	1.5 (38) Union
DT-90, 2.5 (64)	2.5 - 8 (64 - 203) NPT	2.5 x 4 (64 x 102) Red. Coup.	4 (102) Nipple	4 (102) 90° Elbow	4 (102) 45° Elbow	2.5 (64) Union

FOAM MAKERS

ORDERING INFORMATION

FOAM MAKERS	PART NO.	DESCRIPTION	APPROXIMATE SHIPPING WEIGHT	
			lb	kg
	32154	Foam Maker, Model SFM-1.5	7	3
	32155	Foam Maker, Model SFM-2.5	8	4
	32156	Foam Maker, Model DT-30, 1.5	7	3
	32157	Foam Maker, Model DT-90, 2.5	7	3



Solutions That Save.

FOR MORE INFORMATION

Contact any of our worldwide Perimeter Solutions Fire Safety offices or visit:

www.Perimeter-Solutions.com

UNITED STATES

10667 Jersey Blvd.
Rancho Cucamonga, CA 91730
Tel: +1 800 682 3626
Tel: +1 909 983 0772
salesfoamusa@perimeter-solutions.com

EMEA

Polígono de Baiña, Parcela 23
33682 Mieres (Asturias)
Spain
Tel: +34 985 24 29 45
salesfoamemea@perimeter-solutions.com

ASIA PACIFIC

3 Charles Street
St Marys NSW 2760
SAustralia
Tel: +61 2 9673 5300
salesfoamapac@perimeter-solutions.com

perimeter-solutions.com

NOTICE PERIMETER SOLUTIONS MAKES NO REPRESENTATIONS OR WARRANTIES AS TO THE COMPLETENESS OR ACCURACY OF THE INFORMATION INCLUDED HEREIN. THE INFORMATION CONTAINED HEREIN IS NOT INTENDED TO PROVIDE REGULATORY, LEGAL OR EXPERT ADVICE RELATING TO THE PRODUCTS, ITS APPLICATION OR USES. NOTHING CONTAINED HEREIN IS TO BE CONSTRUED AS A RECOMMENDATION TO USE ANY PRODUCT, PROCESS, EQUIPMENT OR FORMULATION IN CONFLICT WITH ANY INDUSTRIAL PROPERTY OR INTELLECTUAL PROPERTY RIGHTS, AND PERIMETER SOLUTIONS MAKES NO REPRESENTATION OR WARRANTY, EXPRESS OR IMPLIED, THAT THE USE THEREOF WILL NOT INFRINGE ON ANY INDUSTRIAL PROPERTY OR INTELLECTUAL PROPERTY RIGHTS. NO REPRESENTATIONS OR WARRANTIES, EITHER EXPRESSED OR IMPLIED, OF MERCHANTABILITY, FITNESS FOR A PARTICULAR PURPOSE OR OF ANY OTHER NATURE ARE MADE HEREUNDER WITH RESPECT TO THE INFORMATION CONTAINED HEREIN.