

INDUSTRIAL NOZZLES - TFT

DESCRIPTION

The Task Force Tips® ZN and ZM INDUSTRIAL NOZZLES are a simple and rugged industrial nozzle with superior stream quality and reach. This fixed flow fog nozzle rated at 100 psi (7 bar) is available with an optional flow rate of 350, 500, 750, 1000 or 1250 (1325, 1893, 2839, 3785 or 4732 l/min).

The fog angle is user adjustable between 120 degree wide fog and straight stream. The nozzle's baffle can be removed with a wrench for flushing debris. The standard inlet is 2.5" NH, NPSH, or BSP (65 mm) female thread. The simple and basic design requires no grease or other maintenance. The rubber bumper is UV resistant. The fixed gpm water nozzle is hardcoat anodized ANSI A356.0 T6 aluminum. The fixed gpm nozzle can be used with water or premixed foam solution.



SPECIFICATIONS

| | |
|---|---|
| K-factor | User Specified K-factor= 15 - 75 |
| Operation Energy Source | Manual |
| Flow Control Method | Fixed flow at a pressure (constant flow rate; flow does not change with pattern) |
| Flow Rate | User Specified K-factor |
| Coupling Size (Nozzles) | 2.5 inch (65 mm) |
| Coupling Style (Nozzles) | Rocker |
| Coupling Swiveling/Rigid (Nozzles) | Rigid |
| Pressure | 100 psi (7 bar) |
| Fog Pattern Method | Molded rubber teeth (fixed) |
| Pattern Actuation Method | Manual |
| Nozzle Bumper Material | Rubber - press fit |
| Certifications | N/A |

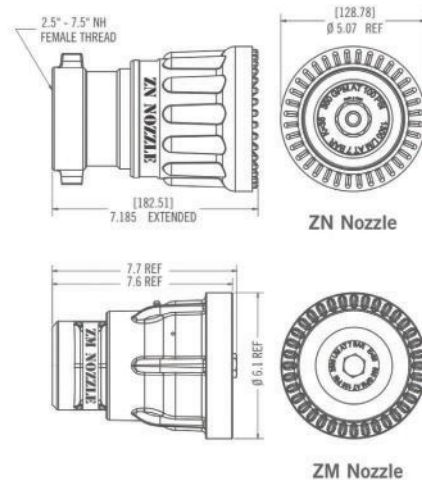

Note: Shown in full fog position

INDUSTRIAL NOZZLES - TFT

REACH CHARTS

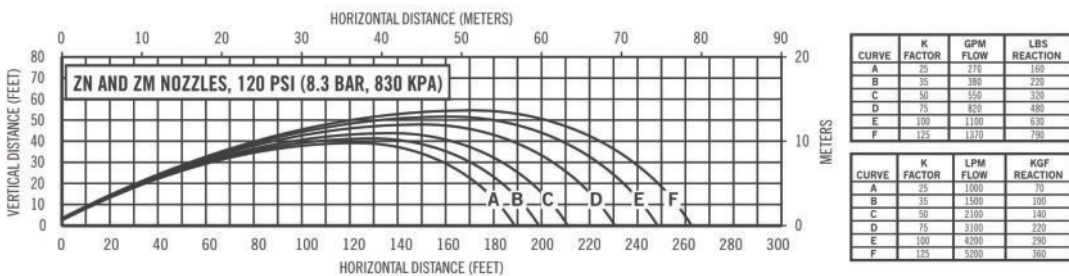
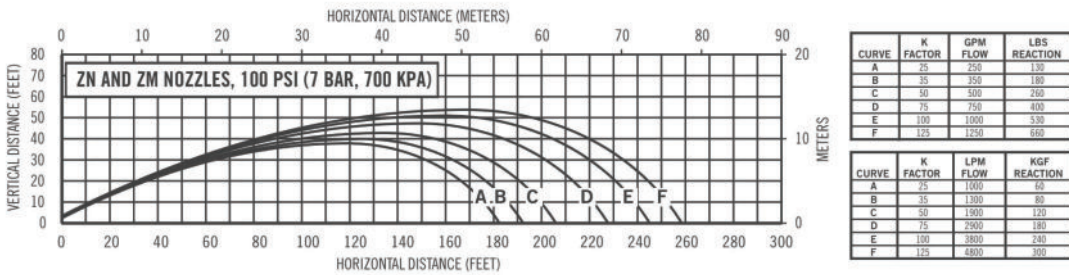
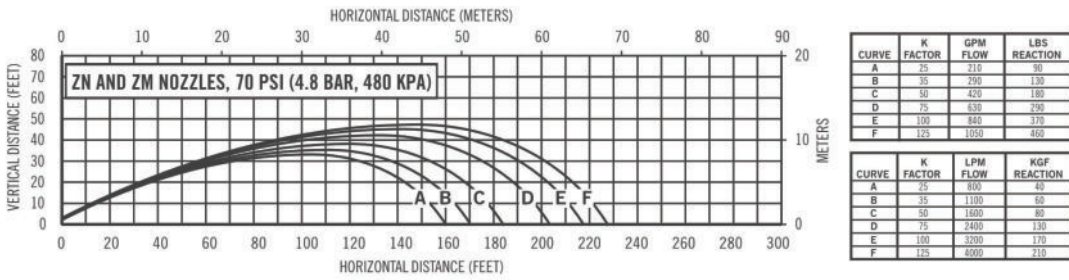

ORDERING INFORMATION

INDUSTRIAL NOZZLES

| PART NO. | DESCRIPTION | lb | kg |
|----------|---|----|----|
| 32230 | ZN Industrial Nozzle - TFT, 350 gpm (1325 l/min) | 4 | 2 |
| 32231 | ZN Industrial Nozzle - TFT, 500 gpm (1893 l/min) | 4 | 2 |
| 32232 | ZN Industrial Nozzle - TFT, 750 gpm (2839 l/min) | 4 | 2 |
| 32237 | ZM Industrial Nozzle - TFT, 1000 gpm (3785 l/min) | 4 | 2 |
| 32238 | ZM Industrial Nozzle - TFT, 1250 gpm (4732 l/min) | 4 | 2 |

APPROXIMATE SHIPPING WEIGHT

Note: Must specify K-factor at time of order



Solutions That Save.

FOR MORE INFORMATION

Contact any of our worldwide Perimeter Solutions Fire Safety offices or visit:

www.Perimeter-Solutions.com

UNITED STATES

10667 Jersey Blvd.
Rancho Cucamonga, CA 91730
Tel: +1 800 682 3626
Tel: +1 909 983 0772
salesfoamusa@perimeter-solutions.com

EMEA

Polígono de Baiña, Parcela 23
33682 Mieres (Asturias)
Spain
Tel: +34 985 24 29 45
salesfoamea@perimeter-solutions.com

ASIA PACIFIC

3 Charles Street
St Marys NSW 2760 – Australia
Tel: +61 2 9673 5300
salesfoamapac@perimeter-solutions.com

perimeter-solutions.com

NOTICE PERIMETER SOLUTIONS MAKES NO REPRESENTATIONS OR WARRANTIES AS TO THE COMPLETENESS OR ACCURACY OF THE INFORMATION INCLUDED HEREIN. THE INFORMATION CONTAINED HEREIN IS NOT INTENDED TO PROVIDE REGULATORY, LEGAL OR EXPERT ADVICE RELATING TO THE PRODUCTS, ITS APPLICATION OR USES. NOTHING CONTAINED HEREIN IS TO BE CONSTRUED AS A RECOMMENDATION TO USE ANY PRODUCT, PROCESS, EQUIPMENT OR FORMULATION IN CONFLICT WITH ANY INDUSTRIAL PROPERTY OR INTELLECTUAL PROPERTY RIGHTS, AND PERIMETER SOLUTIONS MAKES NO REPRESENTATION OR WARRANTY, EXPRESS OR IMPLIED, THAT THE USE THEREOF WILL NOT INFRINGE ON ANY INDUSTRIAL PROPERTY OR INTELLECTUAL PROPERTY RIGHTS. NO REPRESENTATIONS OR WARRANTIES, EITHER EXPRESSED OR IMPLIED, OF MERCHANTABILITY, FITNESS FOR A PARTICULAR PURPOSE OR OF ANY OTHER NATURE ARE MADE HEREUNDER WITH RESPECT TO THE INFORMATION CONTAINED HEREIN.