

FOAM PROPORTIONING TRAILER

FEATURES

- Trailer design offers extreme mobility
- Steel concentrate tanks available in sizes of 500, 750, 1000 gallons (1893, 2839, 3785 liters) Note: Custom designed sizes available.
- High flow capacity
- Wide range of proportioning
- Proportioning system meets the requirements of NFPA 11
- Multiple size tank options
- Trailer constructed of all welded steel
- Meets DOT highway requirements
- UL Listed proportioning system
- Accessory options available including NFPA 1901 compliance
- Easy refilling during operation

DESCRIPTION

The Perimeter Solutions Foam Proportioning Trailer consists of the following: A complete mobile package meeting all applicable NFPA standards consisting of a trailer constructed with frame, wheels, and axles capable of carrying the total charged weight of the trailer assembly and the foam concentrate. The trailer frame includes a tongue jack, electrical connections, NFPA 1901 lighting package, reflective striping, rear mud flaps, and rear stabilizer jacks. Concentrate tanks are available in 500, 750, 1000 gallon (1893, 2839, 3785 liters) capacities. Tanks are constructed of carbon steel in accordance with NFPA 11C "Mobile Foam Apparatus". Tanks contain the required swash partitions and removable gasketed top for ease of filling, cleaning and inspection.

The foam proportioning trailer contains a positive displacement foam concentrate pump which is driven by an air cooled diesel engine complete with electric start. The pump is constructed of materials compatible with all types of fire fighting foam concentrates and can be designed for use with 1%, 3%, or 6% ATC or AFFF foam concentrates. The in-line balance pressure proportioning systems maintains an equal pressure in the foam concentrate and water inlets to the proportioner. This allows the system to be used over a wide range of flow rates and available pressures. A duplex pressure gauge provides a reading of the foam concentrate and water pressure.

APPLICATION

The Perimeter Solutions Foam Proportioning Trailer is designed to provide quick, mobile foam fire protection for

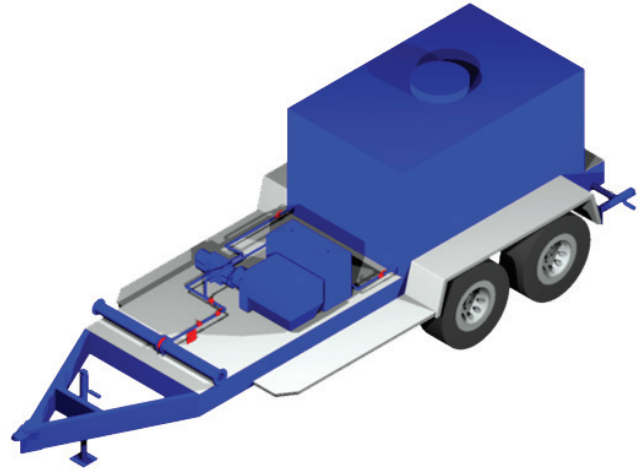

hazards consisting of flammable liquids. These types of hazards can be defined as tank farms, loading racks (both truck and rail), chemical processing plants, and marine off loading/on loading terminals. The trailer storage vessel provides a large capacity supply of foam concentrate.

The Solberg Foam Proportioning Trailer greatly increases the fire fighting ability of industrial, municipal, and military fire emergency responders.

SPECIFICATIONS

Proportioning System

The balanced pressure proportioning system shall contain all required components including; in-line foam proportioner, pressure balancing valve, gauge (duplex), drain, check and control valves, valve identification nameplates, and interconnecting pipe (brass). Balancing of the proportioning system shall be accomplished through the use of a pressure balancing valve. The valve shall sense water inlet pressure and foam concentrate pressure and shall adjust to pressure changes on the foam supply port of the proportioner. The pressure balancing valve shall be constructed of brass, containing all necessary O-rings and seals. The interconnecting piping for foam concentrate shall be of brass construction. The balanced pressure proportioner shall be completely pressure tested.

Trailer Frame

The trailer frame shall be constructed of all welded steel. No bolts, screws, or rivets shall be used in the construction of the frame. The trailer framework shall be constructed of 4.0" x 2.0" x 0.125" (102 mm x 51mm x 3.2 mm) wall steel tubing. The cross members shall be notched at their ends to fit inside of the outer frame channels. Cross members shall be positioned to maximize support for the foam tank, monitors, and plumbing. Two lengths of 4.0" (102 mm) channel shall be welded diagonally between

FOAM PROPORTIONING TRAILER

the coupler and the front corners of the frame. The front of the trailer (monitor operators position), shall be covered with 0.125" (3.2 mm) embossed aluminum diamond plate. Mounting provisions shall be provided for the foam tank(s). The trailer shall be equipped with 2-5/16" (59 mm) coupler, adjustable front jack, two rear stabilizer jacks, and full light package for highway use.

Storage Tank

The metal foam storage tank shall be sized to hold 500, 750, or 1000 gallons (1893, 2839, or 3785 liters) of foam concentrate. The metal tank shall be constructed of painted steel or stainless steel of sufficient gauge.

Foam Tank

Connection Foam connection hoses shall be constructed of 2.0" (50 mm) clear suction hose to allow visual confirmation of foam flow. Cam and groove couplings shall be used to enable quick connection and disconnection of the foam concentrate hoses.

Axles

The axles shall be rated a minimum of 3500 lb (1588 kg) load rating each. The axles shall be bolted to the frame utilizing Grade 8 bolts. The axles shall consist of torsion bar suspension and independent wheel movement to provide maximum shock absorption and proper handling.

Brakes

The trailer assembly shall contain an electric brake system.

NFPA Lighting Package (optional):

The trailer shall contain a light package that meets the minimum warning light and actuation requirements of NFPA 1901 Fire Apparatus Standard (current version).

Finish

The trailer shall be painted with red or blue enamel paint finish.

OPTIONS

Contact Perimeter Solutions Technical Services for options on proportioners, hoses, and other trailer equipment.

DIMENSIONAL INFORMATION

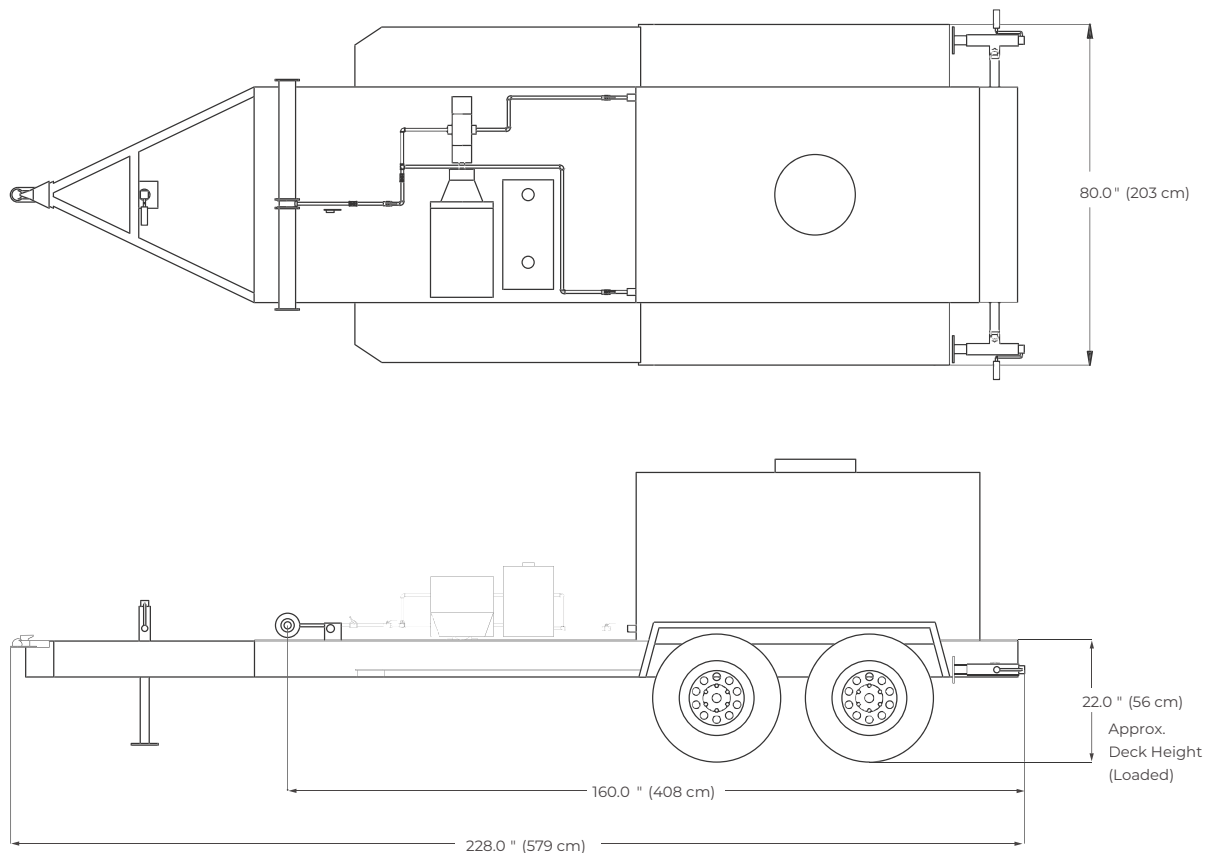

Note: Dimensions are approximates and will vary depending on model and options selected.

FOAM PROPORTIONING TRAILER

ORDERING INFORMATION

Contact Perimeter Solutions Sales or Technical Services Department for options, pricing and delivery.



Solutions That Save.

FOR MORE INFORMATION

Contact any of our worldwide Perimeter Solutions Fire Safety offices or visit:

www.Perimeter-Solutions.com

UNITED STATES

10667 Jersey Blvd.
Rancho Cucamonga, CA 91730

Tel: +1 800 682 3626

Tel: +1 909 983 0772

salesfoamusa@perimeter-solutions.com

EMEA

Polígono de Baiña, Parcela 23
33682 Mieres (Asturias)

Spain

Tel: +34 985 24 29 45

salesfoamemea@perimeter-solutions.com

ASIA PACIFIC

3 Charles Street
St Marys NSW 2760 – Australia

Tel: +61 2 9673 5300

salesfoamapac@perimeter-solutions.com

perimeter-solutions.com

NOTICE PERIMETER SOLUTIONS MAKES NO REPRESENTATIONS OR WARRANTIES AS TO THE COMPLETENESS OR ACCURACY OF THE INFORMATION INCLUDED HEREIN. THE INFORMATION CONTAINED HEREIN IS NOT INTENDED TO PROVIDE REGULATORY, LEGAL OR EXPERT ADVICE RELATING TO THE PRODUCTS, ITS APPLICATION OR USES. NOTHING CONTAINED HEREIN IS TO BE CONSTRUED AS A RECOMMENDATION TO USE ANY PRODUCT, PROCESS, EQUIPMENT OR FORMULATION IN CONFLICT WITH ANY INDUSTRIAL PROPERTY OR INTELLECTUAL PROPERTY RIGHTS, AND PERIMETER SOLUTIONS MAKES NO REPRESENTATION OR WARRANTY, EXPRESS OR IMPLIED, THAT THE USE THEREOF WILL NOT INFRINGE ON ANY INDUSTRIAL PROPERTY OR INTELLECTUAL PROPERTY RIGHTS. NO REPRESENTATIONS OR WARRANTIES, EITHER EXPRESSED OR IMPLIED, OF MERCHANTABILITY, FITNESS FOR A PARTICULAR PURPOSE OR OF ANY OTHER NATURE ARE MADE HEREUNDER WITH RESPECT TO THE INFORMATION CONTAINED HEREIN.