

FOAM STATION



FEATURES

- Completely self-contained unit
- Operates with AFFF or Alcohol Type Concentrates (ATC™)
- Operates with water only
- Rechargeable while in operation
- Storage reel for 1.5" X 100' (38 mm X 30 m) (booster) non-collapsible hose

DESCRIPTION

The Perimeter Solutions Foam Station is a quick knock down, one-man operation foam station. The unit is self-contained, consisting of a 35 gallon (132 litre) stainless steel concentrate tank, eductor, hand line nozzle and non-collapsible hose. When in operation, water is introduced from a dedicated water source through the supply hose to the eductor. While water is passing through the eductor a vacuum is created, which draws foam concentrate out of the tank, up to the eductor and into the water stream, delivering the foam solution.

APPLICATION

The Perimeter Solutions Foam Station is designed to provide firefighting capabilities in various high-hazard high-risk applications such as:

- Aircraft hangars
- Off-shore platforms
- Dike areas
- Spill fires
- Tank farms



SPECIFICATIONS (STANDARD UNIT)

- 1.0" (25 mm) drain valve with plug
- 1.5" (38 mm) 100' non-collapsible hose
- 4.0" (102 mm) PVC fill port and vent
- Stainless steel handle
- 35 gallon (132 litres) stainless steel (304) concentrate tank
- Hand line 95 gpm (360 lpm) Nozzle
- Brass eductor with 95 gpm (360 lpm)
- Brass manifold
- Galvanized hose reel
- Stainless steel pick up tube

OPTIONS

- 50' (15 m), 75' (23 m), 125' (38 m) or 150' (46 m) hose lengths
- 60 gallon (227 litre) concentrate tank
- 316SS, galvanized or carbon steel manifold
- Handline Nozzle
- Stainless steel (316) tank material
- Stainless steel, aluminum or carbon steel hose reel

FOAM STATION

DIMENSIONAL INFORMATION (STANDARD UNIT)

Height:	46" (1168 mm)
Length:	50" (1270 mm)
Width:	35" (889 mm)
Weight with foam:	35 gallon station 400 lbs (181 kg) 60 gallon station 622 lbs (282 kg)

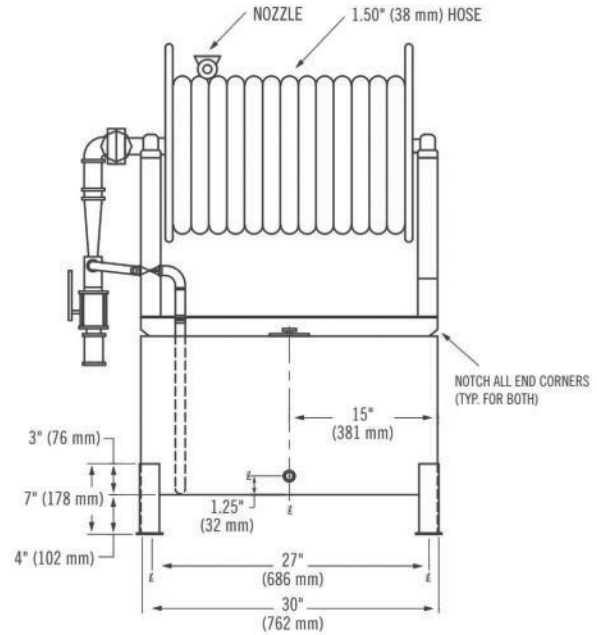
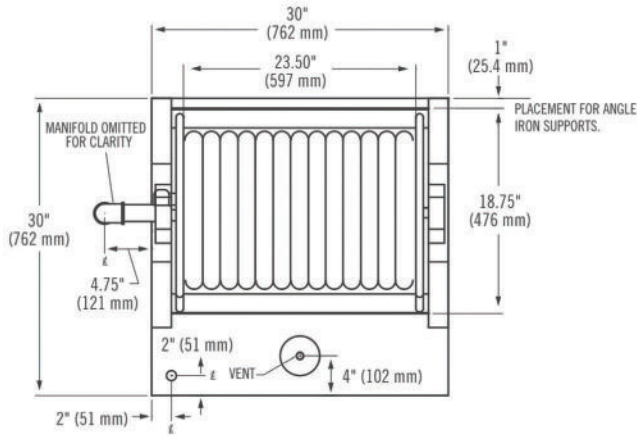

ORDERING INFORMATION

FOAM STATIONS	PART NO.	DESCRIPTION	APPROXIMATE SHIPPING WEIGHT	
			lb	kg
	35002	Foam Station - 35 gallon (133 litre), Stainless Steel, Hose Reel, Nozzle, Hose 75' (23 m), Red Enamel Finish	130	59
	35003	Foam Station - 35 gallon (133 litre), Stainless Steel, Hose Reel, Nozzle, Hose 100' (30 m), Red Enamel Finish	130	59
	35004	Foam Station - 60 gallon (227 litre), Stainless Steel, Hose Reel, Nozzle, Hose 75' (23 m), Red Enamel Finish	160	73
	35005	Foam Station - 60 gallon (227 litre), Stainless Steel, Hose Reel, Nozzle, Hose 100' (30 m), Red Enamel Finish	160	73



Solutions That Save.

FOR MORE INFORMATION

Contact any of our worldwide Perimeter Solutions Fire Safety offices or visit:
www.Perimeter-Solutions.com

UNITED STATES

10667 Jersey Blvd.
Rancho Cucamonga, CA 91730
Tel: +1 800 682 3626
Tel: +1 909 983 0772
salesfoamusa@perimeter-solutions.com

EMEA

Polígono Industrial de Baiña, Parcela 23
33682 Baiña-Mieres (Asturias) – Spain
Tel: +34 985 24 29 45
salesfoamea@perimeter-solutions.com

ASIA PACIFIC

3 Charles Street
St Marys NSW 2760 – Australia
Tel: +61 2 9673 5300
salesfoamapac@perimeter-solutions.com

perimeter-solutions.com

NOTICE PERIMETER SOLUTIONS MAKES NO REPRESENTATIONS OR WARRANTIES AS TO THE COMPLETENESS OR ACCURACY OF THE INFORMATION INCLUDED HEREIN. THE INFORMATION CONTAINED HEREIN IS NOT INTENDED TO PROVIDE REGULATORY, LEGAL OR EXPERT ADVICE RELATING TO THE PRODUCTS, ITS APPLICATION OR USES. NOTHING CONTAINED HEREIN IS TO BE CONSTRUED AS A RECOMMENDATION TO USE ANY PRODUCT, PROCESS, EQUIPMENT OR FORMULATION IN CONFLICT WITH ANY INDUSTRIAL PROPERTY OR INTELLECTUAL PROPERTY RIGHTS, AND PERIMETER SOLUTIONS MAKES NO REPRESENTATION OR WARRANTY, EXPRESS OR IMPLIED, THAT THE USE THEREOF WILL NOT INFRINGE ON ANY INDUSTRIAL PROPERTY OR INTELLECTUAL PROPERTY RIGHTS. NO REPRESENTATIONS OR WARRANTIES, EITHER EXPRESSED OR IMPLIED, OF MERCHANTABILITY, FITNESS FOR A PARTICULAR PURPOSE OR OF ANY OTHER NATURE ARE MADE HEREUNDER WITH RESPECT TO THE INFORMATION CONTAINED HEREIN.