

TWIN-AGENT UNIT 100/30

HARDWARE



Features

Dual agent fire extinguishing capability

100 lb (45 kg) Purple-K dry chemical

30 gallon (114 litres) pre-mix AR-AFFF foam solution

Compact design

One person operation

Suitable for high-hazard, high-risk applications

Available with or without skid foot mount

Description

The SOLBERG® Twin-Agent Unit is designed and constructed for one-person operation. This mobile or fixed firefighting unit can function at its full potential quickly in an emergency situation.

The 100/30 Twin-Agent Unit (TAU) consists of two agent tanks, twin 50 ft (15.2 m) hose and single nitrogen cylinder with regulator assembly to control the pressure flow of gas into the agent tank assemblies. The 100/30 TAU is mounted on a skid frame base for ease of lifting and moving.

Application

The SOLBERG 100/30 Twin-Agent Unit is designed to provide firefighting capabilities in industrial or multiple hazard areas containing Class B fuels. Common high-hazard high-risk areas include:

- Flammable liquid storage
- Fueling stations
- Loading racks
- Docks/jetties
- Mining operations
- Parking garages
- Processing areas
- Rapid intervention vehicles

Performance

The SOLBERG 100/30 TAU is a high-performance firefighting unit capable of extinguishing Class B hydrocarbon and polar solvent fuel fires. Requiring only a single operator for use, this compact unit requires 32 ft³ (0.92 m³) of storage space and is capable of extinguishing at least 200 - 300 ft² (19.0 - 28.0 m²) of flammable/combustible liquid spill area.

The combined twin-agent unit provides extinguishing capability not found with single-agent type units. PURPLE-K dry chemical contains specially fluidized and siliconized potassium bicarbonate



dry chemical which is 2.5 times more effective than regular dry chemical on Class B flammable/combustible liquids (fuel-in-depth, spill fires) and pressurized gases. It is electrically non-conductive. ARCTIC 3x3% ATC pre-mix foam solution can be applied to hydrocarbon and polar solvent fuel fires. The foam solution can be used to prevent ignition or re-ignition of liquid spills and to control hazardous vapors. When used as a twin-agent combination, fuel-in-depth, spill, three-dimensional and pressurized fires are easily extinguished.

Components

The SOLBERG Twin-Agent Unit is a self-contained unit consisting of 100 pounds (45 kg) of AMEREX PURPLE-K dry chemical and 30 gallons (114 litres)

SOLBERG is a member of PERIMETER SOLUTIONS, a global producer of leading fire retardant, gel and foam brands with a singular purpose: revolutionize the course of fire suppression technology with safer, more effective and more sustainable solutions. Together, we are Moving Industries Forward by Redefining Fire Suppression. www.solbergfoam.com

of SOLBERG ARCTIC 3x3% ATC premix solution.

Agent tank assemblies are each equipped with a safety relief valve. A single 110 ft³ (3.11 m³) nitrogen cylinder is used to expel both agents through 50 ft (15 m) of twinned hose connected to the dual agent nozzle. The dry chemical and foam nozzles are mechanically linked and can be operated independently or simultaneously. Each nozzle consists of a bail type slide-valve.

The dry chemical nozzle is designed for an application rate of 5 lbs per second (2.3 kg/s). The nozzle operator can select from six valve settings for an appropriate flow rate of dry chemical agent up to the maximum flow of the system. The foam nozzle features fully automatic pressure control, regulated to approximately 100 psi (6.9 bar) throughout the flow range from 10 to 125 gpm (8.4 to 105 l/min). The nozzle design allows for an adjustable pattern. The effective range of the twin agent unit is 30 ft (9 m) at full flow and proportionately less at lower valve settings.

The SOLBERG 100/30 TAU is actuated by manually opening the lever operated

quick-opening nitrogen cylinder valve.

Options

- Stainless steel tanks
- Vinyl cover

The system is designed with sufficient nitrogen and a suitable valving arrangement so that the hose lines and nozzles can be completely cleared of agent after discharge without discharging any agent remaining in the tanks.

Specifications

The agent tanks are manufactured in compliance with ASME Code Section VIII Division 1 with a 250 psi (17 bar)

rating, tested to 375 psi (26 bar), or 1.5 times the working pressure. The tanks are constructed out of SA 516 Grade 70 carbon steel. The interior of the foam tank is coated with a coal tar epoxy.

Dry Chemical – The potassium bicarbonate dry chemical shall be tested for use with this system and shall meet the requirements of Underwriters Laboratories.

Firefighting Foam – The foam solution for this unit shall be ARCTIC 3x3% ATC AR-AFFF pre-mix.

Note: The approximate fully charged weight of the unit is 960 lb (435 kg).

Dimensional Information

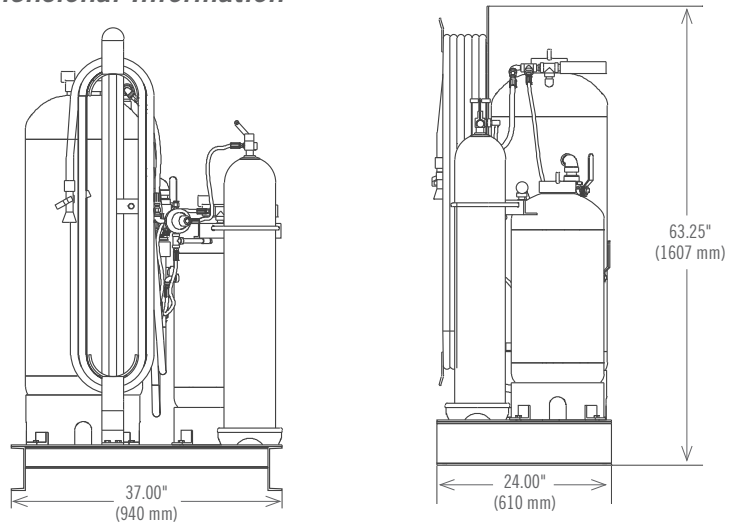

Ordering Information

TWIN-AGENT UNIT

PART NO.	DESCRIPTION	APPROXIMATE SHIPPING WEIGHT	
		lb	kg
41000	Twin-Agent Unit, 100/30, Purple-K Dry Chemical, 3x3% AR-AFFF Pre-Mix Foam	585	265



NOTICE: Perimeter Solutions makes no representations or warranties as to the completeness or accuracy of the information included herein. The information contained herein is not intended to provide regulatory, legal or expert advice relating to the products, its application or uses. Nothing contained herein is to be construed as a recommendation to use any product, process, equipment or formulation in conflict with any industrial property or intellectual property rights, and Perimeter Solutions makes no representation or warranty, express or implied, that the use thereof will not infringe on any industrial property or intellectual property rights. NO REPRESENTATIONS OR WARRANTIES, EITHER EXPRESSED OR IMPLIED, OF MERCHANTABILITY, FITNESS FOR A PARTICULAR PURPOSE OR OF ANY OTHER NATURE ARE MADE HEREUNDER WITH RESPECT TO THE INFORMATION CONTAINED HEREIN.

SOLBERGFOAM.COM

FORM NUMBER F-2015004-1

COPYRIGHT © 2015. ALL RIGHTS RESERVED. SOLBERG, ARCTIC AND ATC ARE TRADEMARKS OF PERIMETER SOLUTIONS OR ITS AFFILIATES.

AMERICAS
 PERIMETER SOLUTIONS, LP
 1520 Brookfield Avenue
 Green Bay, WI 54313
 USA
 Tel: +1 920 593 9445

EMEA
 PERIMETER SOLUTIONS, LP
 Polígono de Baiña, Parcela 23
 33682 Mieres (Asturias)
 Spain
 Tel: +34 985 24 29 45

ASIA PACIFIC
 PERIMETER SOLUTIONS, LP
 3 Charles Street
 St. Marys NSW 2760
 Australia
 Tel: +61 2 9673 5300