

FOAM STATION

HARDWARE



Features

Completely self-contained unit

Operates with AFFF or Alcohol Type Concentrates (ATC™)

Operates with water only

Rechargeable while in operation

Storage reel for 1.5" X 100' (38 mm X 30 m) (booster) non-collapsible hose

Description

The SOLBERG® Foam Station is a quick knock down, one-man operation foam station. The unit is self-contained, consisting of a 35 gallon (132 litre) stainless steel concentrate tank, eductor, handline nozzle and non-collapsible hose. When in operation, water is introduced from a dedicated water source through the supply hose to the eductor. While water is passing through the eductor a vacuum is created, which draws foam concentrate out of the tank, up to the eductor and into the water stream, delivering the foam solution.

Application

The SOLBERG Foam Station is designed to provide firefighting capabilities in various high-hazard high-risk applications such as:

- Aircraft hangars
- Off-shore platforms
- Dike areas
- Spill fires
- Tank farms

Specifications (standard unit)

- 1.0" (25 mm) drain valve with plug
- 1.5" (38 mm) 100' non-collapsible hose
- 4.0" (102 mm) PVC fill port and vent
- Stainless steel handle
- 35 gallon (132 litres) stainless steel (304) concentrate tank
- Handline 95 gpm (360 lpm) Nozzle
- Brass eductor with 95 gpm (360 lpm)
- Brass manifold
- Galvanized hose reel
- Stainless steel pick up tube



Options

- 50' (15 m), 75' (23 m), 125' (38 m) or 150' (46 m) hose lengths
- 60 gallon (227 litre) concentrate tank
- 316SS, galvanized or carbon steel manifold
- Handline Nozzle
- Stainless steel (316) tank material
- Stainless steel, aluminum or carbon steel hose reel

SOLBERG is a member of PERIMETER SOLUTIONS, a global producer of leading fire retardant, gel and foam brands with a singular purpose: revolutionize the course of fire suppression technology with safer, more effective and more sustainable solutions. Together, we are Moving Industries Forward by Redefining Fire Suppression. www.solbergfoam.com

Dimensional Information (standard unit)

Height: 46" (1168 mm)
 Length: 50" (1270 mm)
 Width: 35" (889 mm)
 Weight with foam: 35 gallon station 400 lbs (181 kg)
 60 gallon station 622 lbs (282 kg)

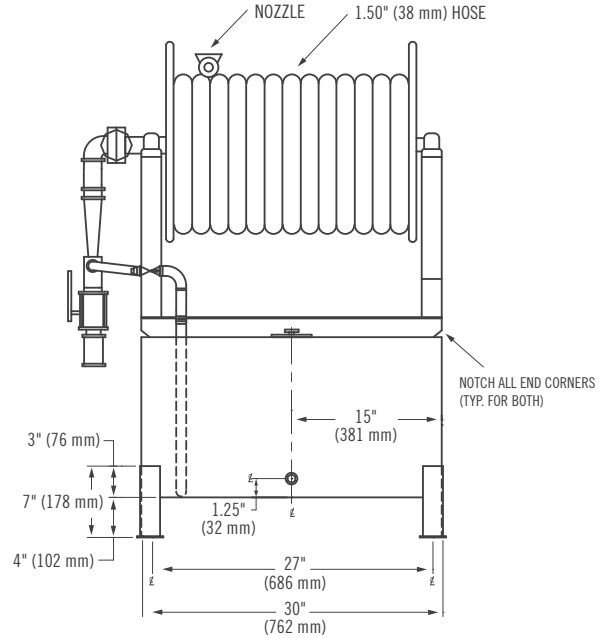
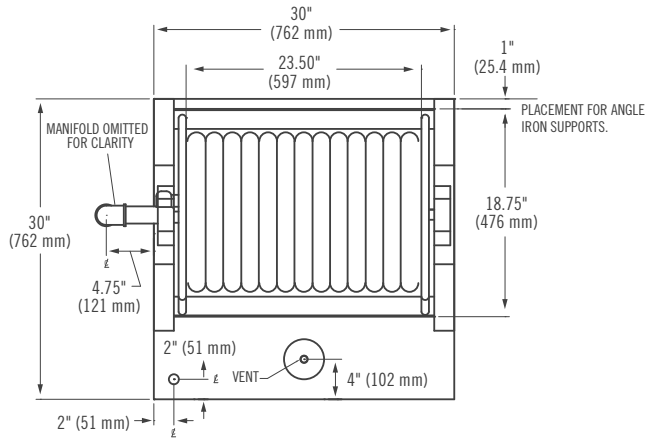

Ordering Information

FOAM STATIONS

PART NO.	DESCRIPTION	APPROXIMATE SHIPPING WEIGHT	
		lb	kg
35002	Foam Station – 35 gallon (133 litre), Stainless Steel, Hose Reel, Nozzle, Hose 75' (23 m), Red Enamel Finish	130 lb	59 kg
35003	Foam Station - 35 gallon (133 litre), Stainless Steel, Hose Reel, Nozzle, Hose 100' (30 m), Red Enamel Finish	130 lb	59 kg
35004	Foam Station - 60 gallon (227 litre), Stainless Steel, Hose Reel, Nozzle, Hose 75' (23 m), Red Enamel Finish	160 lb	73 kg
35005	Foam Station - 60 gallon (227 litre), Stainless Steel, Hose Reel, Nozzle, Hose 100' (30 m), Red Enamel Finish	160 lb	73 kg



NOTICE: Perimeter Solutions makes no representations or warranties as to the completeness or accuracy of the information included herein. The information contained herein is not intended to provide regulatory, legal or expert advice relating to the products, its application or uses. Nothing contained herein is to be construed as a recommendation to use any product, process, equipment or formulation in conflict with any industrial property or intellectual property rights, and Perimeter Solutions makes no representation or warranty, express or implied, that the use thereof will not infringe on any industrial property or intellectual property rights. NO REPRESENTATIONS OR WARRANTIES, EITHER EXPRESSED OR IMPLIED, OF MERCHANTABILITY, FITNESS FOR A PARTICULAR PURPOSE OR OF ANY OTHER NATURE ARE MADE HEREUNDER WITH RESPECT TO THE INFORMATION CONTAINED HEREIN.

SOLBERGFOAM.COM

FORM NUMBER F-2011011-2

COPYRIGHT © 2014. ALL RIGHTS RESERVED.
 SOLBERG IS A TRADEMARK OF PERIMETER SOLUTIONS OR ITS AFFILIATES.

AMERICAS
 PERIMETER SOLUTIONS, LP
 1520 Brookfield Avenue
 Green Bay, WI 54313
 USA
 Tel: +1 920 593 9445

EMEA
 PERIMETER SOLUTIONS, LP
 Poligono de Baiña, Parcela 23
 33682 Mieres (Asturias)
 Spain
 Tel: +34 985 24 29 45

ASIA PACIFIC
 PERIMETER SOLUTIONS, LP
 3 Charles Street
 St. Marys NSW 2760
 Australia
 Tel: +61 2 9673 5300